



Monitoring Devices For Conveyor System



www.fine-tek.com

 **FineTek**

CONVEYOR BELT MISALIGNMENT SWITCH FOR PROTECTION OF BELT CONVEYORS AND PERSONNEL

SRT

This device monitors the operation process for potentially hazardous conditions and activate an alarm when it is occurred misalignment, the SRT series conveyor belt misalignment switch protects the conveyor belt from damage due to belt misalignment or run off .

For normal condition, the belt misalignment switches are generally mounted on both sides and the edge of the conveyor belt .

A small clearance between the contact rollers and a little swaying for the belt edges are allowable. When the swaying exceeds the normal limit (on/ about 20 mm), the belt edge pushes the contact roller, which drives the switch and operates the contacts, the misalignment switch will reset automatically when the belt resumes normal running. These control devices are used in pair on both side of conveyor belt detected place, each unit can be equipped with two micro-switches to produce signals indicating the belt misalignment at two deviation points .

The first signal point could indicate small belt deviation by output an alarm, the second signal point could guard against extreme belt run off by shutting down the conveyor .

The roller is adjustable up to 20° in both directions and is positioned approximately 20mm from the conveyor belt , the switch actuation points are adjustable from 0° to 35° by a simple change of the actuating cams .

DIMENSION

SRT

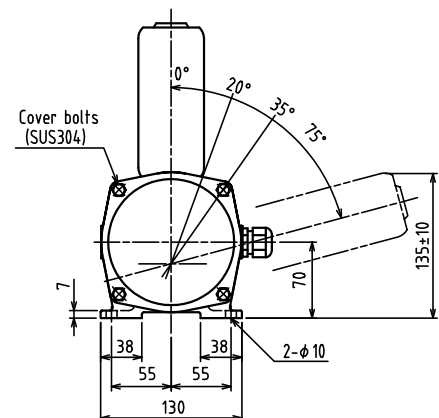
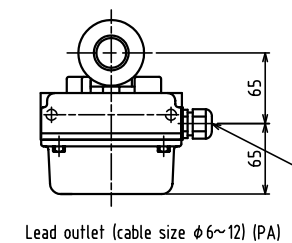
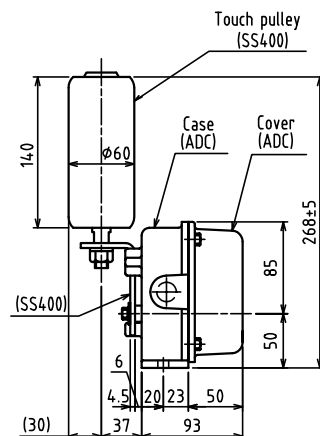

CHARACTERS

- Easy Installation, operation sensitive
- Roller arm can move up to 75 degrees in either direction
- Dust tight, IP 67 weatherproof, Die cast aluminum housing
- Roller lever actuating angle 20° for alarm signal and 35° for shutting down system
- To Save Process downtime, product loss and replacing cost of damaged conveyor belt

APPLICATIONS

- Conventional Belt Conveyors
- Underground, Cable Supported Belt Conveyors
- Stacker / Reclaimer Conveyors
- Ship Loading / Unloading Systems
- Tripper and Shuttle Conveyors
- Crane / Shovel Boom Position Limit Detector
- Apron Feeders & Conveyors
- Heavy Duty Limit Switch

SPECIFICATION

Switching Capacity	15A,125/250 Vac 1/2A 125 Vdc SPDTx2
Action Force	3.4~5.4N.m (0.35~0.55kgf.m)
Reset Way	Auto
Ambient Temp.	-20~60°C
Enclosure Protection Grade	IP67
Enclosure Material	Die cast ADC
Weight	Approx. 2.9kg

SAFETY CABLE PULL SWITCH FOR EMERGENCY OR NORMAL SHUT-OFF

SRS

Belt conveyor safety cable pull switches are designed for providing a switching system to isolate the power to conveyor system and other equivalent process equipment in the emergency condition ◦

The cable pull switches are actuated by a plastic coated steel wire, which are placed along-side the conveyor ◦ When you pull on the cable at any point, it will trip and automatically lock the switches, deenergizing the conveyor starter contactor ◦ Each switch is bi-directional in operation and has two cable fitted to it from opposite directions terminated with a spring at the anchor points, please see drawing 4 the springs will operate the switch on cable breakage ◦

After tripping the mechanical latch can be released only on the switch itself by the reset lever ◦

APPLICATIONS

emergency or normal stop for below facilities

- Conventional Belt Conveyors
- Shuttle Conveyors
- Bucket Elevators
- Packaging Lines
- Stockpile/Reclaim systems, Cranes, Shovels, Draglines
- Ship Loading / Unloading System
- Horizontal Feed Systems

DIMENSION

SRS

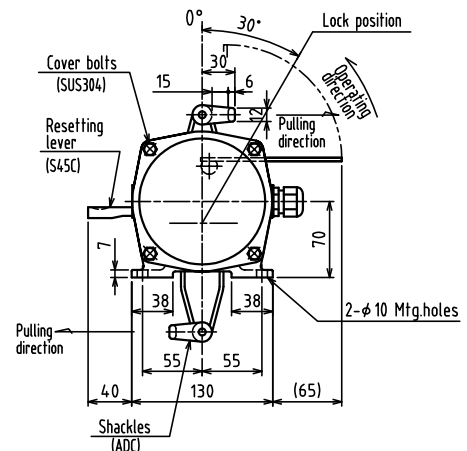
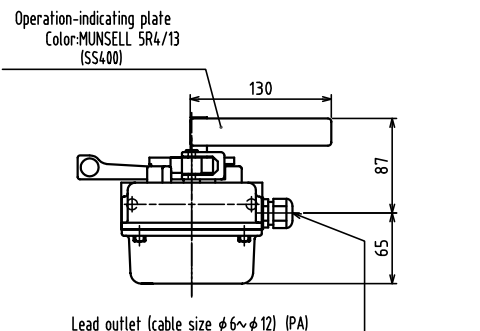
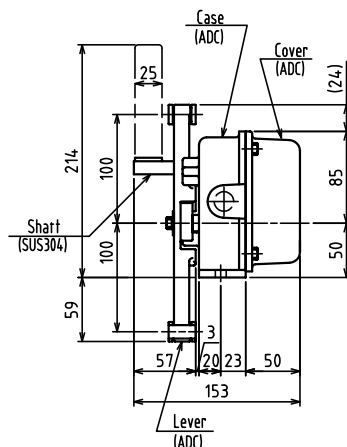

CHARACTERS

- Universal design for bi-direction activation
- Compact design for tight-fit areas, IP67 rugged die cast aluminum housing
- Manual reset lever
- Easily orientated at either end or intermediate position in pull cable run
- Cable Pull 30° for shutting down system
- Highly visible black arm easily shows condition of the switch, indicating alarm or normal

SPECIFICATION

Switching Capacity	15A,125/250 Vac 1/2A 125 Vdc SPDTx2
Action Force	49 ± 9.8n (5 ± 1kgf.m)
Reset Way	Manual
Ambient Temp.	-20~60°C
Enclosure Protection Grade	IP67
Enclosure Material	Die cast ADC
Weight	Approx. 2.9kg

SPEED MONITOR

ED4000

ED4000(SM4) Speed Monitor is a totally new rotational speed monitoring equipment; it uses the principle of photo detector and microprocessor to accurately calculate a wide range of rotational speed. It detects rang 1~999rpm and the rotational speed display on 7-seg led.

There is a contact relay that could be used either for alarm or control purposes during the monitoring process. The alarm set point could be directly set by numerical knobs which is more convenient and more accurate than conventional means. It comes equipped with analog signal output which could be utilized for various display indications and more precise control. It is ideal for applications in monitoring low speed, stop and overload situations.

APPLICATION

- Low speed and overload protection monitoring of various conveyer systems
- Networked circuits to form sequential start or stop
- Frequently used machines: Grain and coal storage bucket elevators and belt conveyer machines

SPECIFICATION

- Measuring Range : 0~999 rpm.
- 7-seg led display 0~999
- Alarm Set point : 1~1999 rpm by rotary switch.
- Alarm Conditions : Underspeed, standstill, power failure.
- Startup Delay : 0 second or 15 Seconds. Selectable
- Alarm Contact Rating : SPDT 5A/250Vac.
- Alarm Delay : 0, 3, 6, 9,....,27 seconds. Selectable
- Speed Analog Output : 4~20mA
- (Signal Range Selectable : 100/200/500/1000rpm).
- Power Supply : 85~265Vac, 50/60Hz
- Power Consumption : 6VA.
- Operating Temperature : -20°C~70°C.
- Housing : Cast Aluminum.
- Protection : IP65
- Cable Entry : 1/2"NPT X 2 hole.

FEATURES

- Maximum monitoring range 1~999rpm.
- 7-seg led display 0~999
- Alarm monitoring: low speed, stop, reverse, blackout and overload.
- Start up delay function allow motor to run up gradually.
- Alarm delay function can avoid fault alarm which many caused by temporary slow down or load changed.
- Selectable rotate direction for both CCW and CW makes installation more versatile.
- Light pulses are not affected by environmental conditions.
- Complementary to FineTek PB/PM series digital Panel meter to indicate speed.

Special Function (built in function)

4~20mA output, proportional to selectable speed range like 100rpm, 200rpm, 500rpm and 1,000rpm.

DIMENSIONS:

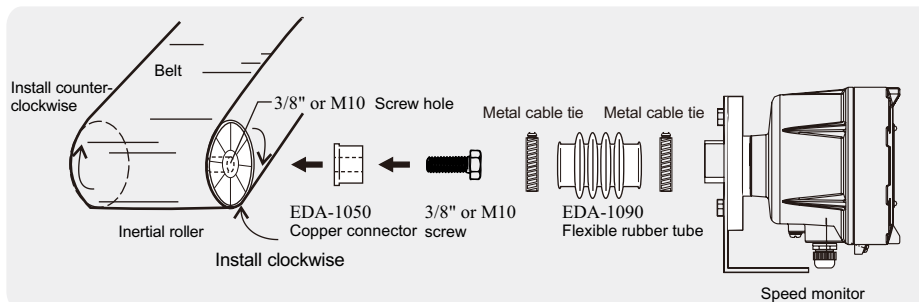
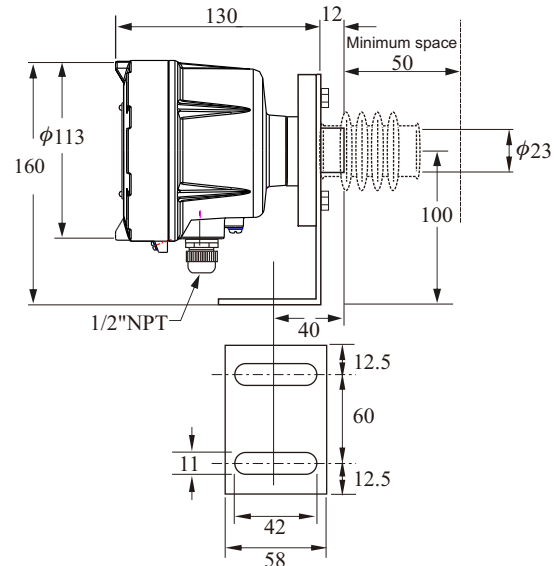

DESCRIPTION OF PANEL

- ① Set point rotary switch
- ② Power & Alarm indicator (Green/Red)
- ③ Start Up Delay Selection Switch
- ④ 4-20mA output range Selection Switch
- ⑤ 7 Segment display

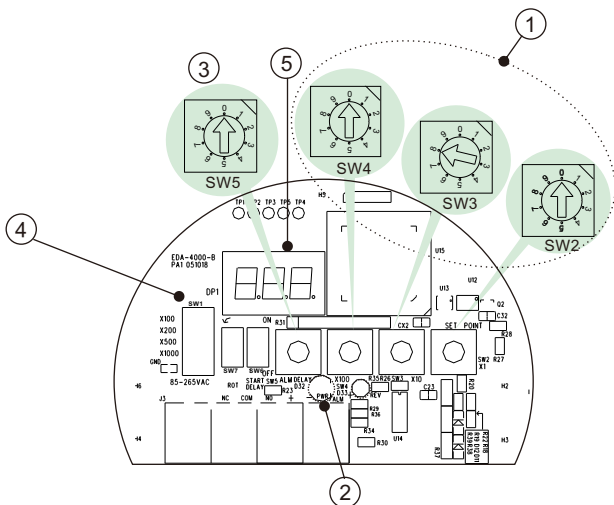

ED TYPICAL APPLICATION

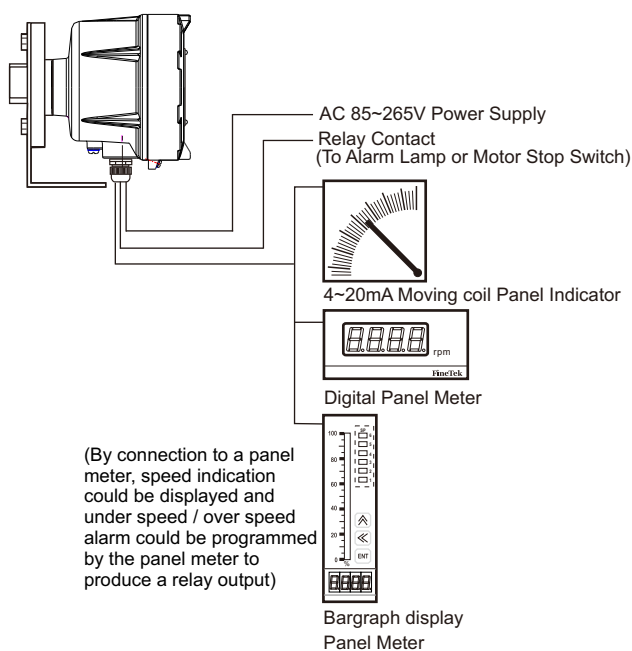

DESCRIPTION OF OPERATION

1. Set point rotary switch

The function of this switch is for setting alarm position. The rotary switch consists of 3 buttons, including x100, x10 and x1. If the setting is at 321rpm, then rotate the SW4 to position 3, rotate the SW3 to position 2 and rotate the SW2 to 1.

2. Alarm indicator (Red)/Power indicator (Green)

1. When the monitor detects the speed lower than the setting point and reach to the alarm delay time or the motor reversed, the alarm relay is actuated and the red light is on spontaneously; vice versa, the red light is off when the speed is rotated back to normal.
2. The function of the green light is to indicate power situation. After switching on the start up delay function and blinking for 15 seconds, the power indicator lights up.

3. Knob time-delay switch

This allows motor speed up slowly without immediate alarm. 0~9 stands for 3~30 seconds. Adjustment unit is at 3 seconds.

Knob point	0	1	2	3	4	5	6	7	8	9
Delay time	3 sec	6 sec	9 sec	12 sec	15 sec	18 sec	21 sec	24 sec	27 sec	30 sec

4. 4-20mA output range Selection Switch

This switch is to convert the detected speed into proportional current output. There are four selections which are 100rpm, 200rpm, 500rpm, 1000rpm. If setting at 500rpm, then the input speed of 0~500 rpm will be converted to 4~20mA output. For example, if the detected speed is at 250rpm, then the current output is 12mA.

CONTROL CIRCUIT DIAGRAM

Below is the diagram of control circuit. Motor speed is monitored by ED4000 (SM4). Motor starts to speed up after activation. ED4000(SM4) starts to monitor after delay time being activated. It monitors if motor is under low speed. When speed is too low, alarm will be issued to stop motor running.

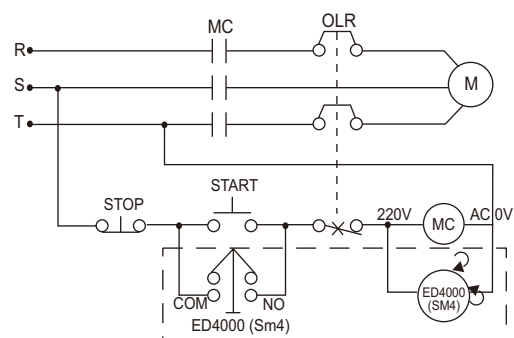

Global Network

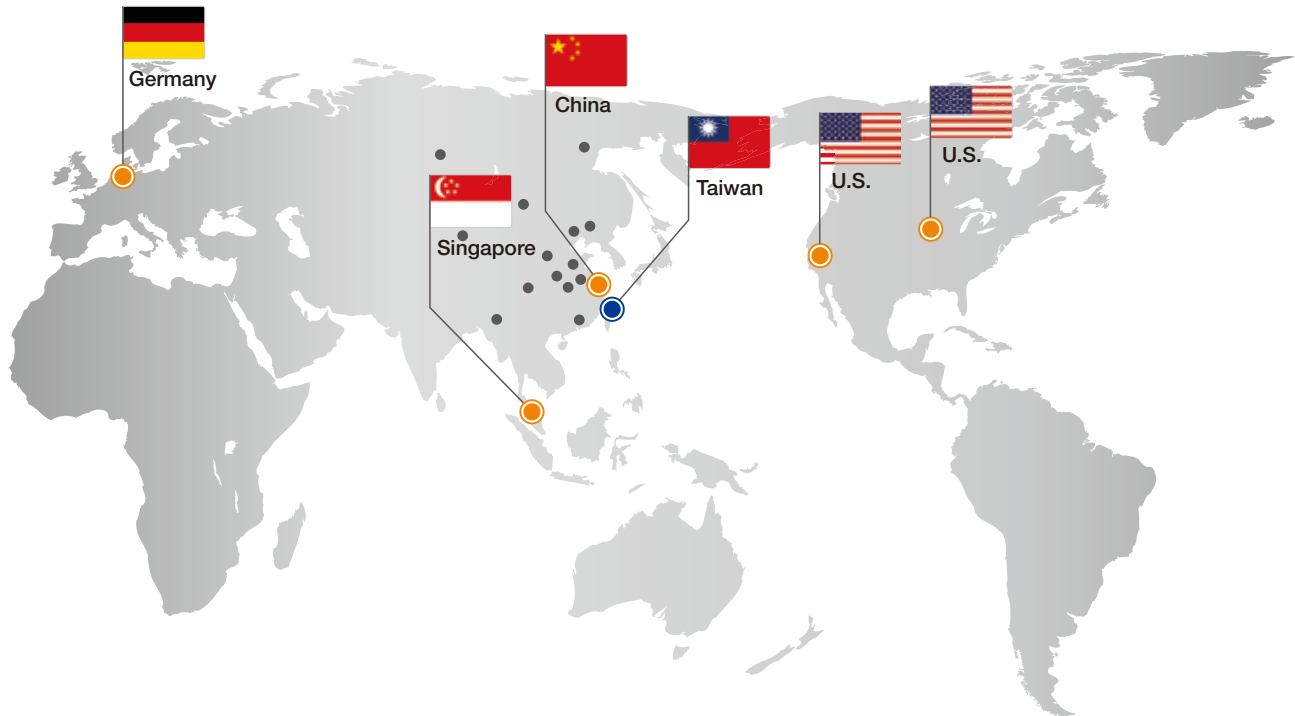

■ Asia

● Taiwan

FINETEK CO., LTD. - Taipei Head Quarter
No.16, Tzuchiang St., Tucheng Industrial Park
New Taipei City 236, Taiwan
TEL: 886-2-2269-6789
FAX: 886-2-2268-6682
EMAIL: info@fine-tek.com

FINETEK CO., LTD. - I-Lan Factory
TEL: 886-3-990-9669
FAX: 886-3-9909659

FINETEK CO., LTD. - Taichung Brance
TEL: 886-4-2337-0825
FAX: 886-4-2337-0836

FINETEK CO., LTD. - Kaohsiung Branch
TEL: 886-7-333-6968
FAX: 886-7-536-8758

● China

FINE AUTOMATION CO., LTD. - Shanghai Factory
No.451 DuHui Rd, MinHang District, Shanghai,
China 201109
TEL: 86-21-6490-7260
FAX: 86-21-6490-7276
EMAIL: info.sh@fine-tek.com

● Singapore

FINETEK PTE LTD. - Singapore Office
No. 60 Kaki Bukit Place, #07-06 Eunos
Techpark 2 Lobby B, Singapore 415979
TEL: 65-6452-6340
FAX: 65-6734-1878
EMAIL: info.sg@fine-tek.com

■ North America

● California, U.S.

APLUS FINETEK SENSOR INC. - US Office
355 S. Lemon Ave, Suite D, Walnut,
CA 91789
TEL: 1 909 598 2488
FAX: 1 909 598 3188
EMAIL: info@aplusfine.com

● Illinois, U.S.

APLUS FINETEK SENSOR INC.
TEL: 1 815 632-3132
FAX: 1 815 716 8464
EMAIL: info@aplusfine.com

■ Europe

● Germany

FineTeK GmbH - Germany Office
Frankfurter Str. 62, OG D-65428
Ruesselsheim, Germany
TEL: +49-(0)6142-17608-0
FAX: +49-(0)6142-17608-20
EMAIL: info@fine-tek.de



Distributor: