

CONTENTS

Page

Section 1	2
• Scope	2
• Introduction	2

Section 2a	Overall Product Range	3
• Crimp contacts		4
- Wire size and tool chart	Table 1a	4
- Barrel dimensions and stripping length	Table 2a	5
• Recommended crimp tool settings	Table 3a	6
• Crimping and assembly tools		7

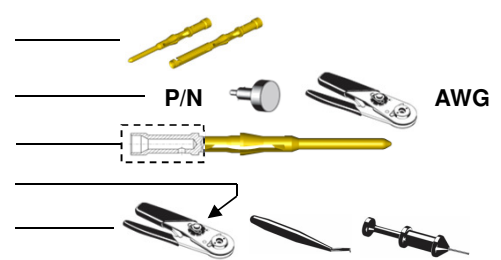

Section 2b	Only for UltiMate™ Size 08 and 11	8
• Crimp contacts		9
- Wire size and tool chart	Table 1b	9
- Barrel dimensions and stripping length	Table 2b	9
• Recommended crimp tool settings	Table 3b	10
• Crimping and assembly tools		10

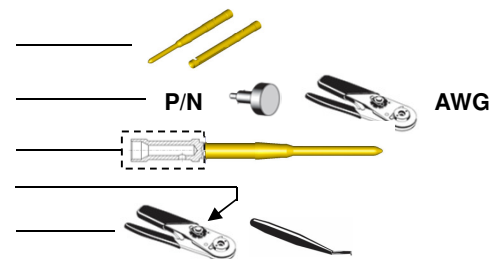

Section 3	11
• Crimp process	12
- Preparation	12
- Stripping	12
- Strand damage and end cuts	13
- Wire insulation damage	13
- Cleanliness	13
- Conductor deformation/birdcaging	13
- Examples of stripping faults	14
- Crimping	15
- Conductor location	15
- Deformation of the crimp barrel	15
- Mechanical properties of the crimped connection	16
- Methods for building up conductor cross-section	16
• Assembly in connector	17
• APPENDIX 1 - Wire size	18

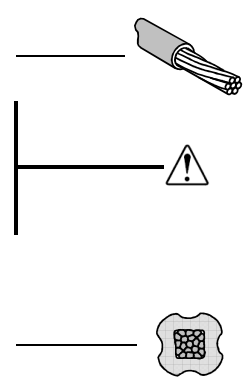

SCOPE

This document provides general guidelines and procedures for understanding and achieving reliable crimp terminations when using Fischer Connectors closed barrel crimp contacts.

Its contents may slightly differ from individual company guidelines and procedures, and is not intended to replace them. Given the broad variety of cable sizes, stranding and qualities, it is always recommended to perform trials to verify and if necessary adapt the procedure to the particular situation and application.

If a conflict occurs between this document and Fischer Connectors' catalogues, this document will take precedence.

INTRODUCTION

The connection between the wire and the terminal is a critical element of any wire termination. A good termination is important because it ensures mechanical integrity and electrical performances required for the application.

Crimping is one common method of achieving this connection. It occurs inside the crimp barrel (terminal) of the contact. There are two types of barrels - open and closed. This specification only deals with closed barrels because all contacts referred in this document are screw-machined which is the usual process for producing this type of barrel.

Wire sections are expressed in AWG (American Wire Gauge), mm² or CMA (Circular Mil Area). See conversion table in **Appendix 1**. Because the wire stranding and insulation type or thickness can vary widely within a particular wire size, it is very important to carefully verify the compatibility between the selected wire and the crimp contact by checking the barrel hole dimensions in **Table 1a**, and **Table 1b** for UltiMate™ Size 08 and 11.

Wire types:

- ☞ Stranded conductors shall be used for crimping.
- Solid round conductors may only be used when their suitability has been proven.



The end result of a properly crimped terminal is a reliable mechanical and electrical connection.

Parts of a machined Fischer Connector crimp contact

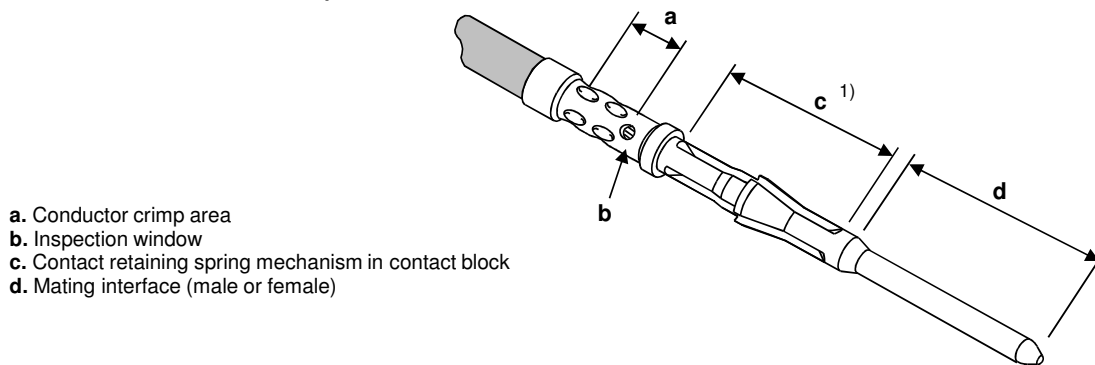







- a. Conductor crimp area
- b. Inspection window
- c. Contact retaining spring mechanism in contact block
- d. Mating interface (male or female)

Note 1: This spring mechanism is not present on crimp contacts for Fischer UltiMate™ Size 08 & 11 products. For this reason these contacts **cannot** be removed from the contact block by means of extraction tools.

CONTENTS

Page

• Crimp contacts	4	
- Wire size and tool chart	4	P/N   AWG
- Barrel dimensions and stripping length	5	
• Recommended crimp tool settings	6	
• Crimping and assembly tools	7	

CRIMP CONTACTS

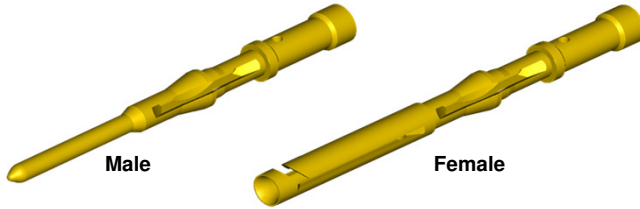

Wire Size and Tool Chart



Crimp style connectors are supplied with the appropriate quantity of crimp contacts. However, replacement contacts may be ordered according to table below.

Crimp contacts **can be removed** from the contact block by means of extraction tools (see extraction tool section).

TABLE 1a

Contact 				Core Series						UltiMate			Positioner 	Crimp Tool 	Wire Size
Size [mm]	Polarity	Part Number	Replaces	102	103	1031	104	105	1051	07	13	18	Part Number	Part Number	AWG
Ø0.5	Male	200.2113	-	•	•					•			TX00.300	TX00.240	32-28 ¹⁾
	Male	200.2172	-			•	•	•			•		TX00.301		
	Female	200.2114	-	•	•					•			TX00.302		
	Female	200.2183	-			•	•						TX00.303		
	Female	200.2412	-					•					TX00.324		
	Female	200.2898	-								•		TX00.373		
Ø0.7	Male	200.2884	200.1682 200.2698	•	•	•	•	•		•		•	TX00.304	TX00.240	28-24 ¹⁾
	Male	200.2887	200.2210						•				TX00.307		
	Male	200.2888	200.2384	•	•	•	•	•		•			TX00.304		
	Female	200.2885	200.1683 200.2760	•	•	•	•			•			TX00.305		
	Female	200.2886	200.2050					•	•				TX00.306		
Ø0.9	Male	200.2890	200.2248	•	•	•	•			•			TX00.307	TX00.240	26-22 ¹⁾
	Male	200.2891	200.2350						•	•			TX00.308		
	Female	200.2892	200.1856	•	•	•	•			•			TX00.309		
	Female	200.2893	200.2143						•	•			TX00.310		
Ø1.3	Male	200.2402	-		•	•	•						TX00.311	TX00.240	24-20 ¹⁾
	Male	200.2403	-						•	•			TX00.338		
	Female	200.2214	-		•	•	•	•	•				TX00.312		
Ø1.6	Male	200.1653	-				•	•	•				TX00.313	TX00.242	18-14 ¹⁾
	Female	200.1654	-				•	•	•				TX00.314		

Note 1: Exceptionally for a given AWG, the diameter of some stranded conductor designs could be larger than the hole diameter of the crimp barrel. Make sure that the conductor diameter fits into the hole. See barrel dimensions in **Table 2a** on page 5.

Legend

• = Compatible

CRIMP CONTACTS (Cont.)

Barrel Dimensions and Stripping Length

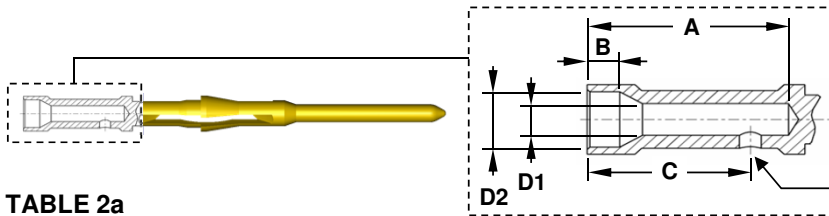

All contacts listed below are insulation support style machined crimp contacts except Ø1.6 contacts.

The wire insulation shall fit into D2.

TABLE 2a

Contact			Barrel dimensions					Stripping length ¹⁾			
Size [mm]	Polarity	Part Number	A min	B	C	D1 min	D2 min				
Ø0.5	Male	200.2113	3.0 (0.118")	0.5 (0.020")	2.5 (0.098")	0.43 (0.017")	0.83 (0.033")		2.5 (0.098")		
	Male	200.2172									
	Female	200.2114									
	Female	200.2183									
	Female	200.2412									
	Female	200.2898									
Ø0.7	Male	200.1682	3.4 (0.134")	0.8 (0.031")	3.1 (0.122")	0.60 (0.024")	1.11 (0.044")		2.6 (0.102")		
	Male	200.2210									
	Male	200.2384									
	Male	200.2698									
	Female	200.1683									
	Female	200.2050									
	Female	200.2760									
	Male	200.2884	3.4 (0.134")	0.6 (0.024")	3.1 (0.122")	0.62 (0.024")	1.11 (0.044")		2.8 (0.110")		
	Male	200.2887									
	Male	200.2888									
Female	200.2885										
Female	200.2886				0.65 (0.026")						
Ø0.9	Male	200.2248	3.3 (0.130")	0.7 (0.028")	3.1 (0.122")	0.82 (0.032")	1.56 (0.061")		2.6 (0.102")		
	Male	200.2350									
	Female	200.1856	3.5 (0.138")					0.80 (0.031")	1.48 (0.058")		2.8 (0.110")
	Female	200.2143									
	Male	200.2890	3.3 (0.130")	0.5 (0.020")	3.1 (0.122")	0.83 (0.033")	1.56 (0.061")		2.8 (0.110")		
	Male	200.2891									
	Female	200.2892									
	Female	200.2893									
Ø1.3	Male	200.2402	3.3 (0.130")	0.7 (0.028")	3.0 (0.118")	1.18 (0.046")	1.76 (0.069")		2.6 (0.102")		
	Male	200.2403									
	Female	200.2214	3.6 (0.142")		3.5 (0.138")				2.9 (0.114")		
Ø1.6	Male	200.1653	5.0 (0.197")	N/A	4.7 (0.185")	1.78 (0.070")	N/A		6.0 (0.236")		
	Female	200.1654									



Note 1: See chapter on **Stripping** on page 12 for definition of stripping length.

All dimensions shown are in millimeters (*inches*) and are for reference only.

RECOMMENDED CRIMP TOOL SETTINGS

These settings are only for use with the adequate crimp tool (see page 7).

TABLE 3a

Contact 			Crimp Tool Setting 					
Size [mm]	Polarity	Part Number	Wire Size AWG					
Ø0.5	Male	200.2113	→	→				
	Male	200.2172						
	Female	200.2114			32	2		
	Female	200.2183			30	3		
	Female	200.2412			28 ¹⁾	4		
	Female	200.2898						
Ø0.7	Male	200.1682	→	→				
	Male	200.2210						
	Male	200.2384			28	6		
	Male	200.2698			26	6		
	Female	200.1683			24 ¹⁾	7		
	Female	200.2050						
	Female	200.2760						
	Male	200.2884			→	→		
	Male	200.2887					28	5
	Male	200.2888					26	5
Female	200.2885	24 ¹⁾	6					
Female	200.2886							
Ø0.9	Male	200.2248	→	→				
	Male	200.2350						
	Female	200.1856			26	6		
	Female	200.2143			24	7		
	Male	200.2890			22 ¹⁾	8		
	Male	200.2891			→	→		
	Female	200.2892					26	5
	Female	200.2893					24	5
		22 ¹⁾	6					
Ø1.3	Male	200.2402	→	→				
	Male	200.2403			24	7		
	Female	200.2214			22	8		
Ø1.6	Male	200.1653	→	→				
	Female	200.1654			18	5		
					16	6		
			14 ¹⁾	6				

Note 1: Exceptionally for a given AWG, the diameter of some stranded conductor designs could be larger than the hole diameter of the crimp barrel. Make sure that the conductor diameter fits into the hole. See barrel dimensions in **Table 2a** on page 5.

CRIMPING AND ASSEMBLY TOOLS

Crimp Tool ULTRA PRECISION for closed crimp termination

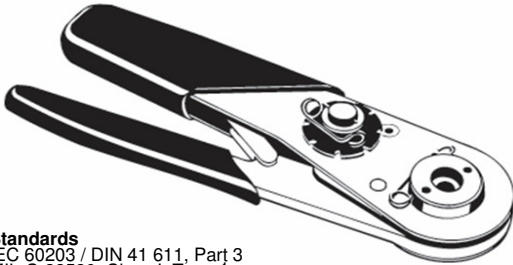

Standards
IEC 60203 / DIN 41 611, Part 3
MIL-C-22520, Class I, Type 1

Contact Size [mm]	C Crimp Tool	Part Number
Ø0.5	BALMAR 18 - 000 or DANIELS MH - 800	TX00.240
Ø0.7		
Ø0.9		
Ø1.3		
Ø1.6	ASTRO TOOL 615708	TX00.242

The best choice of precision crimp tools for highly reliable eight indenter crimping per US-MIL, IEC and DIN Specifications.

These hand tools have an integral mechanism to control the crimping operation to the extend that, once the crimping operation has been started, the crimping tool cannot be opened until the crimping cycle has been completed (full-cycle/ratcheting tool).

Positioners have to be ordered according to contact.
See **Table 1a** on page 4.

Contact Insertion Tool



Material
- Handle: POM (black Delrin®)
- Fork: Tool Steel, chrome plated

Contact Size [mm]	Part Number
Ø0.5	TX00.214
Ø0.7	TX00.210
Ø0.9	TX00.211
Ø1.3	TX00.273

Tool for inserting male and female removable crimp contacts into the contact block.

Especially recommended for small gauge and fragile wires.

Contact Extraction Tool

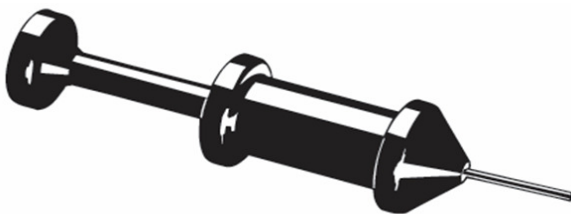

Material
- Housing and Plunger: POM (black Delrin®)
- Sleeve: Stainless Steel
- Slide: Tool Steel







Contact Size [mm]	Part Number
Ø0.5	TX00.213
Ø0.7	TX00.200
Ø0.9	TX00.205
Ø1.3	TX00.212
Ø1.6	TX00.201

Tool for extracting male and female removable crimp contacts from the contact block.

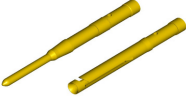
The sleeve of this tool is pushed over the contact, thereby releasing the contact retaining mechanism. The tool plunger is then pushed to eject the contact.

CONTENTS

Page

• Crimp contacts	9	
- Wire size and tool chart	9	 P/N  AWG
- Barrel dimensions and stripping length	9	
• Recommended crimp tool settings	10	
• Crimping and assembly tools	10	

CRIMP CONTACTS

Wire Size and Tool Chart

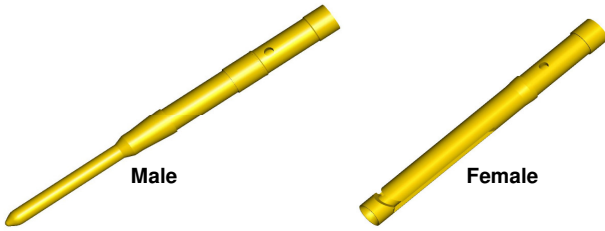

Crimp style connectors are supplied with the appropriate quantity of crimp contacts. However, replacement contacts may be ordered according to table below.

Crimp contacts **cannot** be removed from the contact block by means of extraction tools.

TABLE 1b

Contact				UltiMate Size						Positioner	Crimp Tool	Wire Size
Size [mm]	Polarity	Part Number	Replaces	07	08	11	13	18	-	Part Number	Part Number	AWG
Ø0.7	Male	200.2895	-		•	•				TX00.301	TX00.240	28-24 ¹⁾
	Female	200.2896	-		•	•				TX00.370		

Note 1: Exceptionally for a given AWG, the diameter of some stranded conductor designs could be larger than the hole diameter of the crimp barrel. Make sure that the conductor diameter fits into the hole. See barrel dimensions in Table 2b below.

Legend

• = Compatible

Barrel Dimensions and Stripping Length

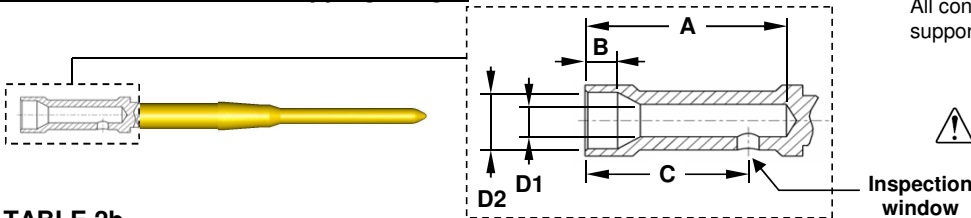

All contacts below are injected insulating support style crimp contacts.

The wire insulation shall fit into D2.

TABLE 2b

Contact			Barrel dimensions					Stripping length
Size [mm]	Polarity	Part Number	A min	B	C	D1 min	D2 min	
Ø0.7	Male	200.2895	3.4 (0.134")	0.6 (0.024")	3.1 (0.122")	0.62(0.024") 0.65(0.026")	1.01 (0.039")	2.8 (0.110")
	Female	200.2896						

All dimensions shown are in millimeters (inches) and are for reference only.

RECOMMENDED CRIMP TOOL SETTINGS

These settings are only for use with the adequate crimp tool (see below).

TABLE 3b

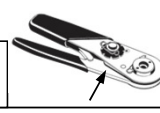
Contact			Crimp Tool Setting	
Size [mm]	Polarity	Part Number	Wire Size AWG	
Ø0.7	Male	200.2895	28 ¹⁾	4
	Female	200.2896	26 ¹⁾	5
			24 ¹⁾	6

Note 1: Exceptionally for a given AWG, the diameter of some stranded conductor designs could be larger than the hole diameter of the crimp barrel. Make sure that the conductor diameter fits into the hole. See barrel dimensions in **Table 2b** on page 9.

CRIMPING AND ASSEMBLY TOOLS

Crimp Tool ULTRA PRECISION for closed crimp termination

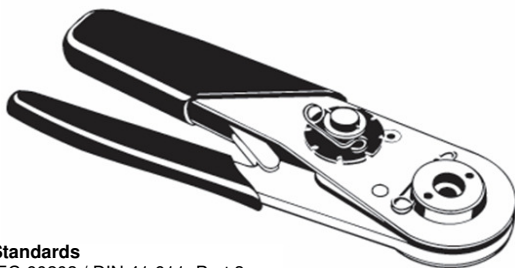

Standards
IEC 60203 / DIN 41 611, Part 3
MIL-C-22520, Class I, Type 1

Contact Size [mm]	C Crimp Tool	Part Number
Ø0.7	BALMAR 18 - 000 or DANIELS MH - 800	TX00.240

The best choice of precision crimp tools for highly reliable eight indenter crimping per US-MIL, IEC and DIN Specifications.

These hand tools have an integral mechanism to control the crimping operation to the extent that, once the crimping operation has been started, the crimping tool cannot be opened until the crimping cycle has been completed (full-cycle/ratcheting tool).

Positioners have to be ordered according to contact. See **Table 1b** on page 9.

Contact Insertion Tool

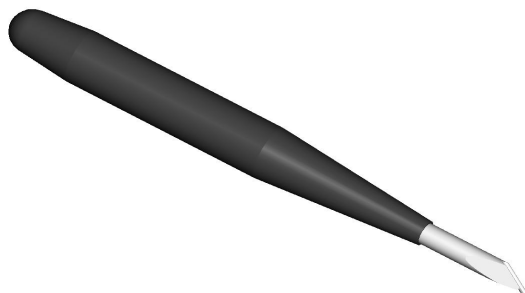

Contact Size [mm]	Part Number
Ø0.7	TX00.372

Material
- Handle: POM (black Delrin®)
- Fork: Tool Steel, chrome plated

Tool for inserting male and female crimp contacts into the contact block.

CONTENTS

Page

• Crimp process	12	
- Preparation	12	
- Stripping	12	
- Strand damage and end cuts	13	
- Wire insulation damage	13	
- Cleanliness	13	
- Conductor deformation/birdcaging	13	
- Examples of stripping faults	14	
- Crimping	15	
- Conductor location	15	
- Deformation of the crimp barrel	15	
- Mechanical properties of the crimped connection	16	
- Methods for building up conductor cross-section	16	
• Assembly in connector	17	
• APPENDIX 1 - Wire size	18	

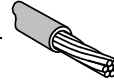

CRIMP PROCESS

Stranded conductors shall not be soldered/tin dipped in that part which is intended to be crimped. After crimping, no additional soldering should take place.

Some reasons for failure of crimped joints to meet minimum tensile requirements include nicked wires, nicked or ruptured strands, strand turn back at crimp joint, and ruptured wires outside of the crimped terminal. To avoid these problems, use the correct size wire for the barrel, prepare your wire carefully, and use the proper crimping tool.

PREPARATION

Stripping:

Wire insulation may be removed using chemical, thermal or mechanical strippers. Chemical insulation stripping agent shall be used only for solid wires. In order to obtain a good and stable crimped connection, it is necessary to strip the wire correctly, i.e. the required stripping length depends on the type and size of the crimp barrel used as described below. See **Table 2a**, and **2b** for UltiMate™ Size 08 and 11, for barrel dimensions **A** and **B**, position of inspection hole **C**, and stripping length.

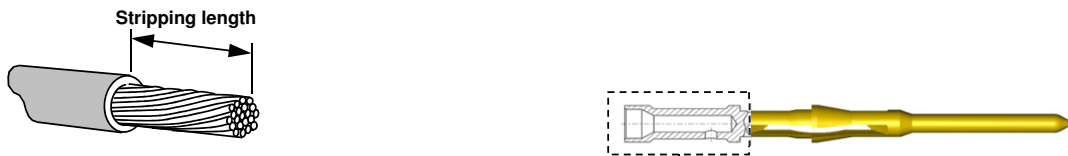

Insulation support style contact:

The wire insulation shall be inserted into the support barrel of the contact, i.e. no insulation clearance is allowed.

$$\text{Stripping length} = A - B$$

If the insulation diameter is larger than the entry funnel, then apply rule below for contact without insulation support.

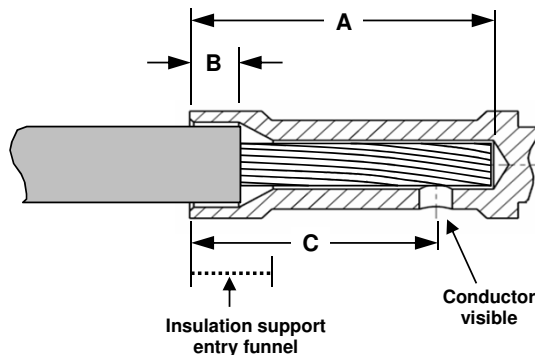

Contact without insulation support:

As rule of thumb:

$$\text{Stripping length} = A + 1 \text{ mm (up to } 1 \text{ mm}^2\text{)}$$

If the insulation clearance is too large, then there is a danger of short circuit.

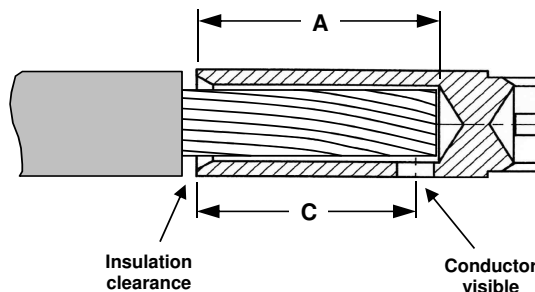

CRIMP PROCESS (Cont.)

Strand damage and end cuts:

The strands stripped part of the conductor shall not be damaged, for example partly or totally broken, as it can lead to degraded performance. Tools utilized to accomplish wire cut shall be selected and used to provide repetitive and consistent wire cut terminations. The process of wire cutting shall be performed such that the cut ends are uniform and all strands are the same length.



Do NOT tin the wire with solder before crimping

Wire insulation damage:

Indents on the wire insulation caused by the stripping tool which do not damage the insulation are permitted if there are no cuts, breaks, cracks or splits in insulation. Coatings added over insulation base material such as resin coatings over polyimide are not considered to be part of the insulation.

Cleanliness:

The stripped part of the conductor shall be clean and free of heavy, non-conductive films such as oxides, sulfides, and similar substances., and free from particles of insulation.

Conductor deformation/birdcaging:

The strands shall not be flattened, untwisted, buckled, kinked or otherwise deformed. The lay of the strands shall be correct. If the lay has been disturbed, it may be restored by a light twist to approximate the original spiral lay of the wire. Care should be taken not to over-twist the strands.

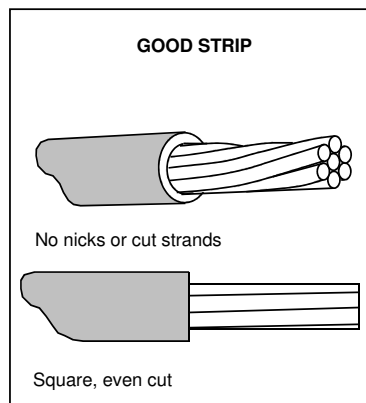

CRIMP PROCESS (Cont.)

Examples of Stripping Faults

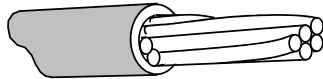

Distance between stripping blades too small:
Strands damaged or removed

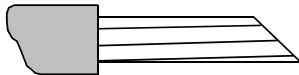

Not appropriate stripping tool:
Cut at angle

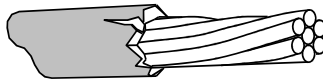

Blunt stripping blades or incorrect distance between the blades:
Tapered, torn, split or burred insulation

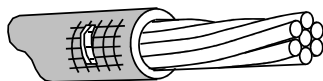

The grip of the stripping tool is damaged or there are metal shavings within the grip:
Insulation is damaged.

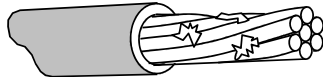

Stripping blades either blunt or not correctly adjusted:
Particles of insulation left on the stripped part of the wire

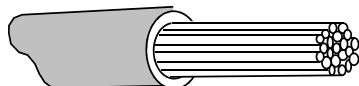

Inappropriate handling of stripped wire:
Strands untwisted

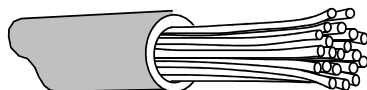

Inappropriate handling of stripped wire:
Strands untwisted and wire bundle splayed



Inappropriate handling of stripped wire:

- **Wire strands extend beyond wire insulation outside diameter.**
- **Wire strands are kinked.**

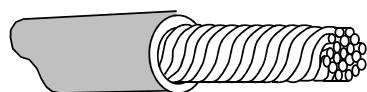

The strands are overtightened; therefore the distribution of strands within the crimp barrel is not assured (increase of the wire cross-section)

CRIMP PROCESS (Cont.)

CRIMPING

Conductor location:

The conductor shall be correctly located in the barrel, i.e. to the correct depth. It must be visible inside the inspection window. All conductor strands shall be within the barrel. There shall be no damaged strands.

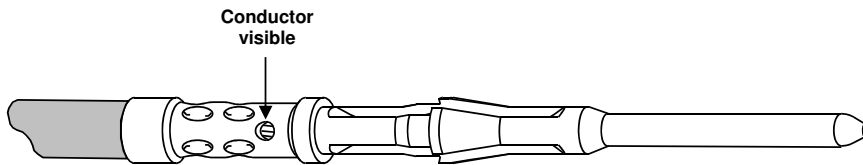

Deformation of the crimp barrel:

The figures below show the crimping of the same contact but with two different wire sizes. The smaller wire requires a deeper deformation of the crimp barrel which is achieved by selecting the recommended crimp tool setting in **Table 3a**, and **3b** for UltiMate™ Size 08 and 11.

Cross-sections before crimping:

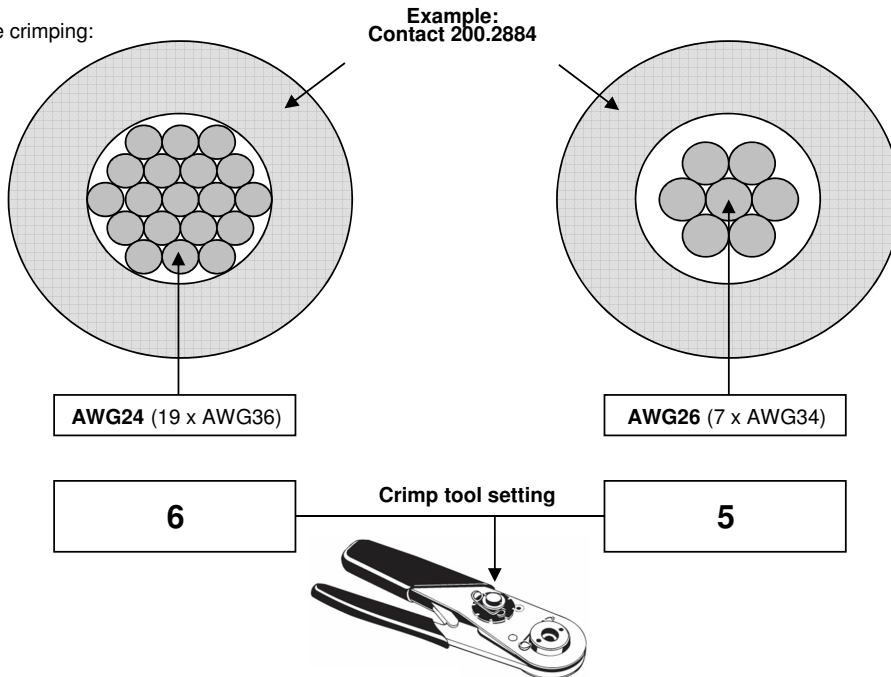

With the aid of cross-section equipment it is possible to verify the quality of the crimp. Each strand should be compressed and deformed, crimp settings may be adjusted to get void free strand compression.

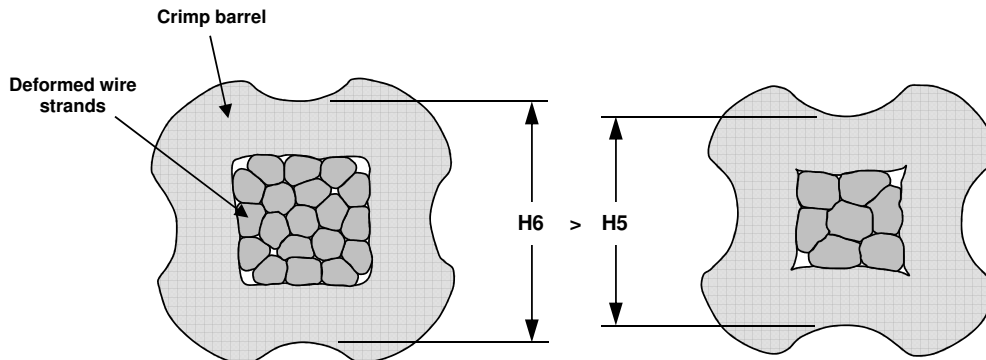

CRIMP PROCESS (Cont.)

Mechanical Properties of the Crimped Connection

For each contact and compatible wire combination, a proper crimp requires a crimp dimension (or height) that offers the highest performance.

The tensile test or pull test is the most widely used field test for evaluating the mechanical properties of the crimped connection. The chart on the existing page shows the requirements of the IEC 60352-2 for various wire sizes. The force indicates the minimum acceptable force to break or separate terminal from the conductor.

- If the crimp dimension is too small, then the conductor is over-crimped and the wire strands could be damaged. This could also create a heat rise across the termination because of increased resistance.

- If this dimension is too large, then the conductor is under-crimped and the wire strands will not be deformed enough.

In both cases the result will be a lower pull out force.

Pull out force of crimped connections ¹⁾

Conductor cross-section		Pull out force
[mm ²]	AWG ²⁾	[N]
0.05	30	6
0.08	28	11
0.12	26	15
0.14	-	18
0.22	24	28
0.25	-	32
0.32	22	40
0.5	20	60
0.75	-	85
0.82	18	90

Note 1: Source: IEC 60352-2, § 5.2.2.1

Note 2: For information only

Methods for Building up Conductor Cross-Section



In some industries, the use of the methods described below is not recommended.

Normally, crimped connections are made with one wire in a crimp barrel. However under certain circumstances, when the wire size is smaller than the acceptable range of the crimp barrel, one of the following methods or a combination of both can be used to build up the correct cross-section :

- The conductor is folded or bent back:

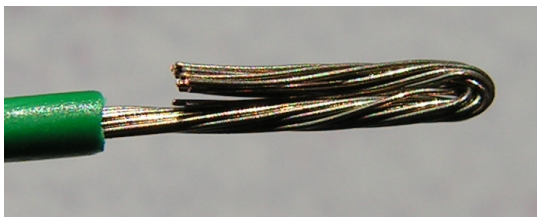

- The conductor area is increased by the use of bare (non-insulated) filler conductors as needed:

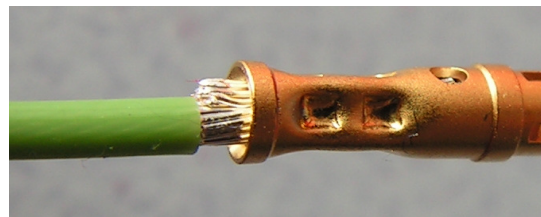

☞ Attention should be paid to the following items:

- The filler shall be visible at the wire entry end of the barrel.
- The filler conductors and/or the wire conductor are visible in the inspection window of the contact.
- The filler conductor is of the same type conductor as the wire being crimped into the contact.
(Gauge can be different as needed but the base metal and the plating, if any, need to be the same).

ASSEMBLY IN CONNECTOR



A certain play in the bloc is necessary for the crimp contacts.
Never twist the cable and wires during the cable assembly.

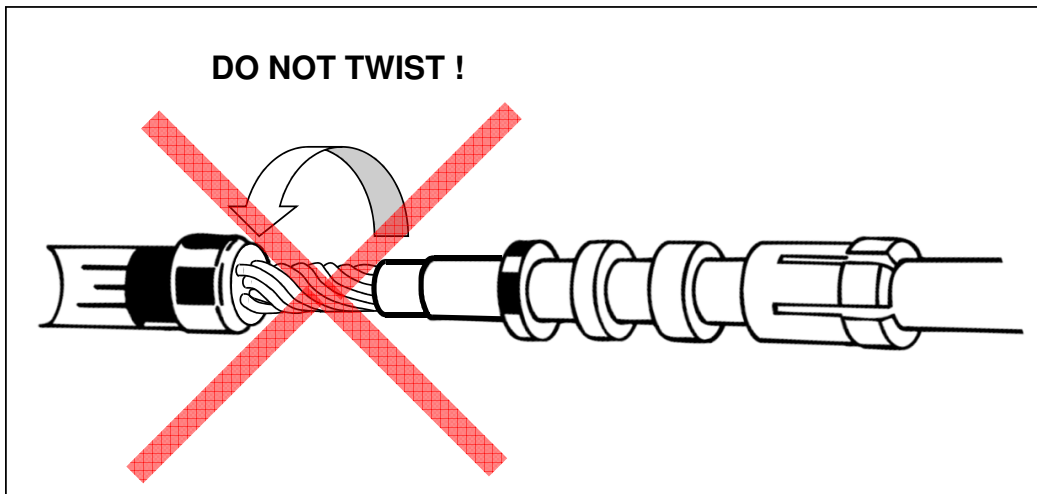
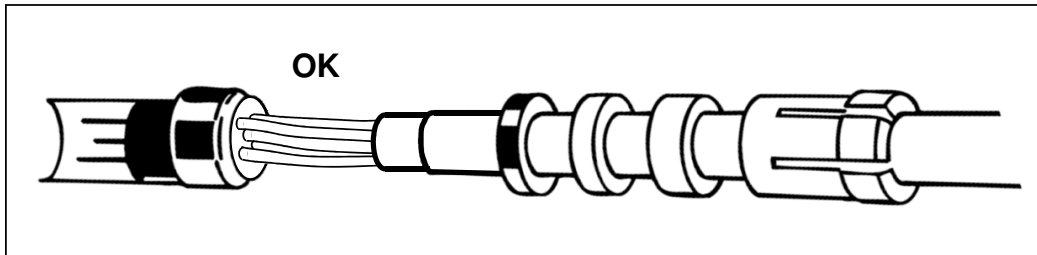

APPENDIX 1 - WIRE SIZE

This chart is intended for reference only.

AWG	Stranding	Diameter		Effective Cross-Sectional Area CMA ¹⁾ mm ²
		Inches	mm	
23	Solid	0.023	0.57	0.258
22	Solid	0.025	0.64	0.326
22	7/30	0.030	0.76	0.356
22	19/34	0.032	0.81	0.383
22	26/36	0.029	0.74	0.329
21	Solid	0.028	0.72	0.410
20	Solid	0.032	0.81	0.518
20	7/28	0.038	0.97	0.567
20	10/30	0.036	0.91	0.509
20	19/32	0.038	0.97	0.609
20	26/34	0.040	1.02	0.524
20	41/36	0.038	0.97	0.519
19	Solid	0.036	0.91	0.653
18	Solid	0.040	1.02	0.823
18	7/26	0.046	1.17	0.901
18	16/30	0.046	1.17	0.815
18	19/30	0.048	1.22	0.968
18	41/34	0.046	1.17	0.826
18	65/36	0.048	1.22	0.823
17	Solid	0.045	1.15	1.038
16	Solid	0.051	1.29	1.309
16	7/24	0.060	1.52	1.433
16	19/29	0.054	1.37	1.220
16	26/30	0.058	1.47	1.324
16	65/34	0.059	1.50	1.309
16	105/36	0.059	1.50	1.330
15	Solid	0.057	1.45	1.650
14	Solid	0.064	1.63	2.081
14	7/22	0.073	1.86	2.279
14	19/27	0.068	1.73	1.940
14	41/30	0.070	1.78	2.088
14	105/34	0.086	2.18	2.115

Number of strands ←
Size of each strand in AWG ←

AWG	Stranding	Diameter		Effective Cross-Sectional Area CMA ¹⁾ mm ²
		Inches	mm	
44	Solid	0.0020	0.050	0.002
42	Solid	0.0025	0.063	0.003
40	Solid	0.0031	0.080	0.005
39	Solid	0.0036	0.090	0.006
38	Solid	0.0040	0.10	0.008
37	Solid	0.0045	0.11	0.010
36	Solid	0.0050	0.13	0.013
35	Solid	0.0056	0.14	0.016
34	Solid	0.0063	0.16	0.020
33	Solid	0.0071	0.18	0.025
32	Solid	0.0080	0.20	0.032
32	7/40	0.0090	0.23	0.035
32	19/44	0.0080	0.20	0.038
31	Solid	0.0089	0.23	0.040
30	Solid	0.010	0.25	0.051
30	7/38	0.012	0.30	0.056
30	19/42	0.013	0.33	0.060
29	Solid	0.011	0.29	0.064
28	Solid	0.013	0.32	0.081
28	7/36	0.015	0.38	0.089
28	19/40	0.016	0.41	0.095
27	1/27	0.014	0.36	0.102
27	7/35	0.017	0.43	0.112
27	65/44	0.018	0.46	0.129
26	Solid	0.016	0.40	0.129
26	7/34	0.019	0.48	0.141
26	10/36	0.020	0.51	0.127
26	19/38	0.020	0.51	0.151
25	Solid	0.018	0.45	0.162
24	Solid	0.020	0.51	0.205
24	7/32	0.024	0.61	0.224
24	10/34	0.023	0.58	0.201
24	19/36	0.025	0.64	0.241
24	41/40	0.024	0.61	0.205

Note 1: Circular Mil Area (CMA):
A circular mil is the cross-sectional area of a wire one mill (0.001 inches) in diameter.