



Sat-Light Platinum Series

Long Distance L-Band Fiber Optic Links



Features & Benefits

- ❖ L-Band: 950–3000MHz
- ❖ Transmission distance up to 100Km
- ❖ Optimized version for Uplink and Downlink applications
- ❖ Powerful management capabilities via a front panel LCD and rack mounted SNMP
- ❖ LNB power control via LCD or SNMP: +13 or 18 VDC
- ❖ CWDM and DWDM options available for multiple L-Band channel transmission

Product Description

Foxcom's Platinum L-Band products are designed to meet the increasing demand for modularity and high-performance in a small form factor for superior long-distance transmission. The link performs at full capability up to 100Km. High RF input power and wide dynamic range make the link suitable for both Uplink and Downlink applications.

Utilizing Foxcom's **DigiRF** technology, the user has full control of all important functions for setup, operation, and analysis via the front panel LCD or via the associated sub-rack SNMP capability.

In addition **IMizer**, an automated adjustable link calibration embedded system enables the user to align the RF links IMD/CNR to specific linearity performances without a two-tone test. Select the desired IMD for the optical transmitter, either locally or remotely, **IMizer** automatically adjusts the laser drive to meet the IMD requirements.

Each low profile individual transmitter or receiver can be "hot swapped" in the sub-rack chassis maintaining a best subsystem uptime capability. Each module contains an individual processor to maximize specification performance at all times under demanding user applications.

The **Platinum** transmitter and receiver are designed for sub-rack chassis mounting. The associated Platinum chassis has 12 active slots, one main control processor (MCP) slot and two redundant power supplies. No fans are required even under full sub-rack loading and full LNB powering.

PL7220 Link Specifications (Downlink Optimized)

RF Specifications	With 10dB Receiver (R10)	With 16dB Receiver (R16)	With 25dB Receiver (R25)
Frequency Range – Bandwidth	950–3000MHz		
Amplitude Response @ Unity Gain 950–3000 MHz any 36 MHz	±2 ±0.25dB		
Gain Variation over Temperature	±1.5dB		
Gain Stability dB/25hr	±0.2dB		
SFDR ¹	>100 dB/Hz ^{2/3}	>88 dB/Hz ^{2/3}	>88 dB/Hz ^{2/3}
Noise Figure (NF)	10dB ¹	20dB ²	33dB ²
Output IP3 (OIP3) ⁴	0dBm		
CNR [any 36MHz] ¹	>57dB	>40dB (16dB Opt loss)	>25dB (25dB Opt loss)
Group Delay Variation	<1.5ns		
Third Order Inter-Modulation [IMD] ³	-55 to -40dBc		
AGC/MGC RF In/Out Signal Range ⁶	-25 to -50dBm		
Operating RF Input Signal Range	-5 to -50dBm		
TX/RX Input / Output Return Loss 50 Ohm 75 Ohm ⁷	-15dB -13dB		
RF Connector Options	N/SMA/F/BNC50/BNC75		
Optical Specifications	Value		
Optical Wavelength	1310nm/1550nm/CWDM		
Optical Power Output	2mW / 3dBm		
Optical Budget / Distance ⁸	10dB/25Km	16dB/40Km	25dB/65Km
Optical Alarm Trigger dBm ⁵	Above -2 / Below -7	Above -7 / Below -13	Above -12 / Below -22
Optical Connector Types	FC-APC / SC-APC / E2000-APC		

1. -40dBm RF input, link gain=20dB, IMD=-40dBc@3dB optical budget
2. -50dBm RF input, link gain=20dB, IMD=-40dBc@16dB optical budget or @25dB optical budget
3. User adjustable
4. -25dBm RF out @ IMD=50dBc
5. Bi Color Led for additional indication before alarm triggering point
6. Within optical budget, no RF alarm indication
7. -11dB above 2.2GHz
8. G652D Fiber. Almost double when 1550nm laser is installed

PL7230 Link Specifications (Uplink Optimized)

RF Specifications	With 10dB Receiver (R10)	With 16dB Receiver (R16)
Frequency Range – Bandwidth	950–3000MHz	
Amplitude Response @ Unity Gain 950–3000 MHz any 36 MHz	±2 ±0.25dB	
Gain Variation over Temperature	±1.5dB	
Gain Stability dB/25hr	±0.2dB	
SFDR ¹	>104 dB/Hz ^{2/3}	>104 dB/Hz ^{2/3}
Noise Figure (NF)	24 dB ¹	32 dB ²
Output IP3 (OIP3) ⁴	20dBm	
CNR [any 36MHz] ¹	>55dB	>45dB (16dB Opt loss)
Group Delay Variation	<1.5ns	
Third Order Inter-Modulation [IMD] ³	-55 to -40dBc	
AGC/MGC RF In/Out Signal Range ⁶	-5 to -30dBm	
Operating RF Input Signal Range	+2 to -30dBm	
TX/RX Input / Output Return Loss 50 Ohm 75 Ohm ⁷	-15dB -13dB	
RF Connector Options	N/SMA/F/BNC50/BNC75	
Optical Specifications	Value	Value
Optical Wavelength	1310nm/1550nm/CWDM	
Optical Power Output	2mW / 3dBm	
Optical Budget / Distance ⁸	10dB/25Km	16dB/40Km
Min RX Optical Input Power dBm ⁵	Above -2 / Below -7	Above -7 / Below -13
Optical Connector Types	FC-APC / SC-APC / E2000-APC	

1. -20dBm RF input, link gain=20dB, IMD=-40dBc@10dB optical budget
2. -25dBm RF input, link gain=20dB, IMD=-40dBc@16dB optical budget
3. User adjustable
4. -5dBm RF out @ IMD=50dBc
5. Bi Color Led for additional indication before alarm triggering point
6. Within optical budget, no RF alarm indication
7. -11dB above 2.2GHz
8. G652D Fiber. Almost double when 1550nm laser is installed

Sat-Light Platinum Series

Advanced Technology

Chassis

FIGURE 1: REAR VIEW OF 12 SLOT CHASSIS WITH ONE MCP SLOT AND DUAL POWER SUPPLY SLOTS



Transmitter and Receiver with LCD and LED Indicators

FIGURE 2: TRANSMITTER WITH LCD AND LED INDICATORS

(Only Transmitter is shown here; Receivers are available and provide corresponding information.)

LED Name	Color	Description
Power	Green	Power On
	No Light	Power Off
Status/Alarms	Green	No Alarms
	Amber	Minor Alarms
	Red	Critical Alarm
RF Input	Green	Input within specification
	Amber	Input below specifications
	Red	No input or above specifications
Remote	Yellow	Main processor control in effect
	No Light	No Main Processor Control



SNMP Graphic User Interface (GUI) for Monitoring & Control

FIGURE 3: SNMP GUI



The SNMP GUI enables the user to perform detailed monitoring & control of the system, including detection, such as:

- General data about the system, including version control
- Card status
- Optical power input and output monitoring
- RF power input and output monitoring
- AGC/MGC selection
- LNB voltage selection (18V/13V/none)
- IMD selection (TX only)
- Power supply monitoring, such as DC voltage, AC/DC failures, temperature, fan speed
- Alarm history and alarm severity
- System statistics

Typical Long Distance L-Band Downlink with CWDM / DWDM

FIGURE 4: TYPICAL L-BAND SYSTEM

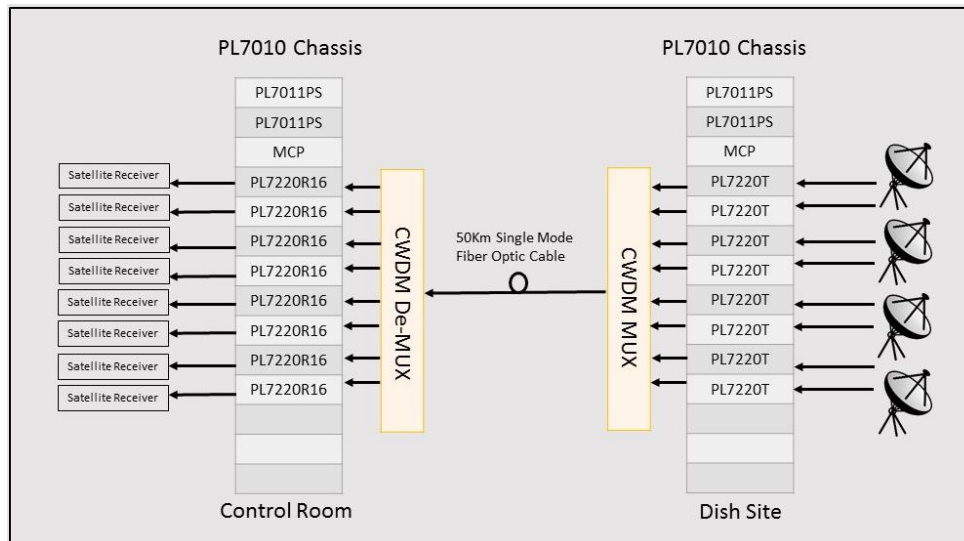

Figure 4 represents a typical L-band downlink from a remote dish site. The system is comprised of 2 sets of 19" 3RU indoor chassis (PL7010) with dual power supplies and an MCP Card.

The downlink consists of eight PL7220T transmitters at the antenna site receiving eight L-band signals from four antennas and eight PL7220R16 receivers at the indoor site.

An 8-channel CWDM MUX combines all eight outputs of the optical transmitters and multiplexes them into a single fiber. The combined signals are de-multiplexed at the receiver / indoor site by the De-MUX and fed into eight separate optical receivers.

Ordering Matrix

Transmitter Ordering Matrix

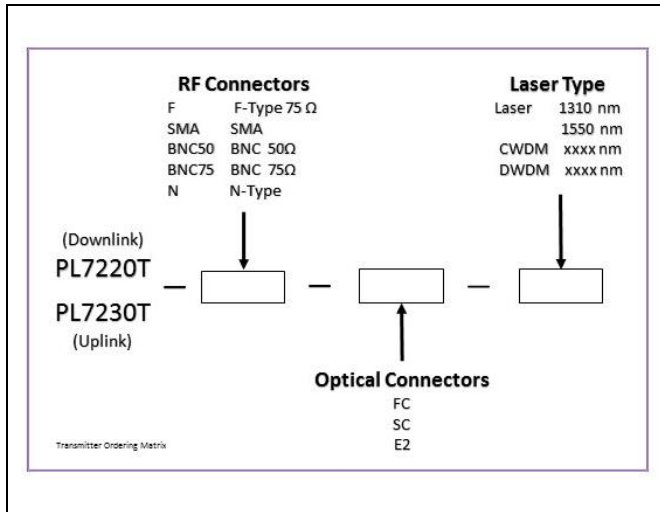

Receiver Ordering Matrix

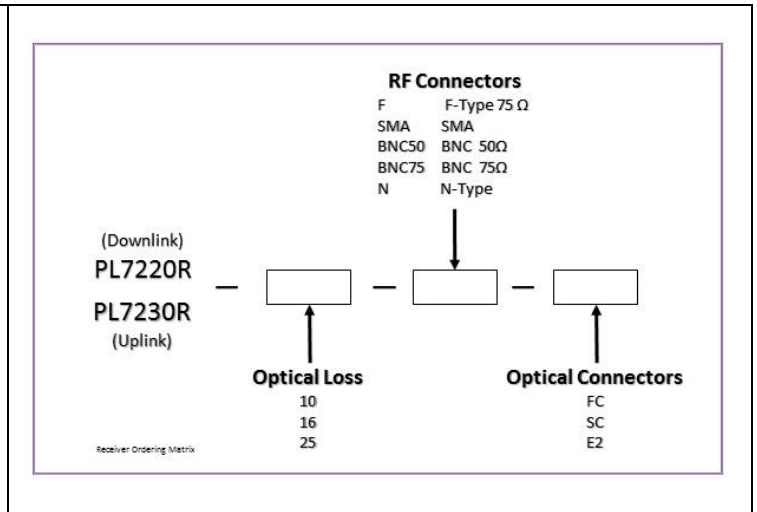

Example of a Typical Downlink Transmitter Part Number: PL7220T – BNC 75 – FC –1310

Example of a Typical Uplink Transmitter Part Number: PL7230T – BNC 75 – FC –1310

Recommended Accessories

Active Accessories

- ❖ 28dB Gain RF Amp
- ❖ 55dB Gain RF Amp
- ❖ Redundancy RF Switch
- ❖ Optical Ethernet Link

Passive Accessories

- ❖ Wideband RF Splitter
- ❖ 10MHz/L-Band Diplexer
- ❖ L-Band RF Splitter
- ❖ 2way Optical Splitter
- ❖ 1310/1550nm MUX/De-MUX
- ❖ 8/16 channel MUX / De-MUX
- ❖ DWDM MUX/De-MUX