

Dialight

.....



Vigilant[®] LED Floodlight - CE

for Indoor and Outdoor Industrial Applications

CE

On when it matters most.

Products and solutions that protect your business





Features & Benefits

- 10 year full performance warranty
- L70 rated for >100,000 hours @ 25°C ambient
- Universal input (120-277V AC)
- Instant on/off
- Superior colour rendition index compared to HPS, LPS, MV
- Maintenance free
- Mercury free
- No UV or IR
- Resistant to shock and vibration
- Temperature compensation technology for longer life

Application

The Vigilant® LED Floodlight represents the future of energy efficient facility illumination for industrial applications worldwide. The lighting fixture consumes at least 50% less energy than traditional HID light sources, while reducing maintenance and carbon emissions. This product incorporates both cutting edge LED technology along with proprietary optics to achieve flood lighting comparable with other traditional light sources.

Vigilant® LED Floodlight - CE

Standard Models

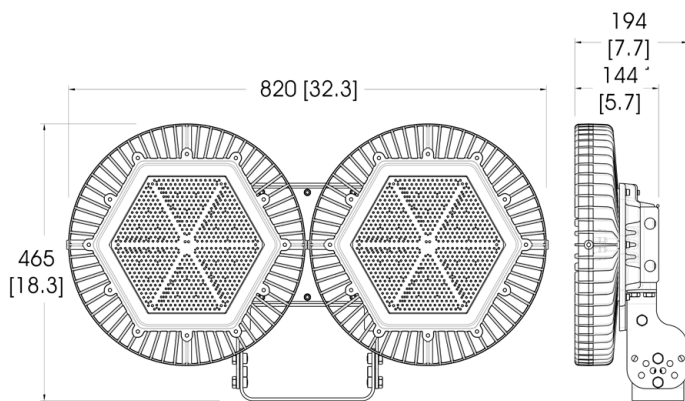
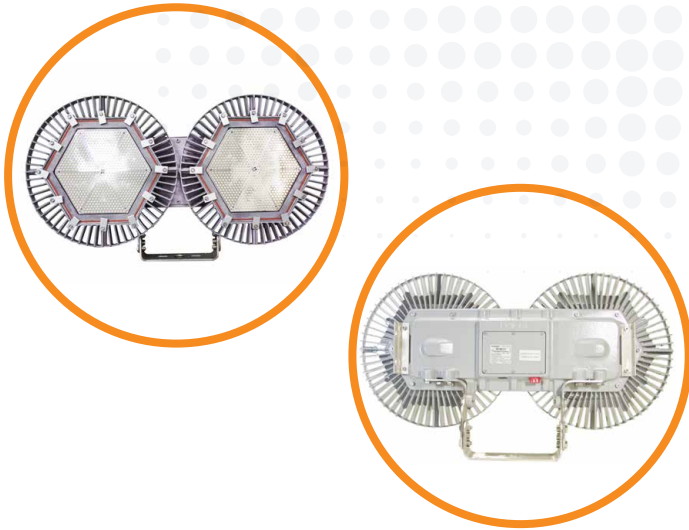

Dimensions in mm (inches)

Certifications & Ratings

- CE
- EN 55015
- EN 61547
- EN 60598
- EN 62031
- EN 62471
- IP66 to EN60529

Mechanical Information:

Fixture weight:	23 kg (56 lbs)
Shipping weight:	27 kg (60 lbs)
EPA (Sq.ft):	2.69
Mounting:	Stainless steel trunnion mounting bracket included
Entries:	(2) M20 cable entries

Electrical Specifications:

Operating voltage:	120 - 277V AC, 50/60Hz
Power consumption:	See table
Operating temp:	-40°C to +65°C (-40°F to +149°F)
Harmonics:	EN 55015 - conducted and radiated EN 61000-3-2 EN 61000-4-3 EN 61000-4-4 EN 61000-4-6 EN 61000-4-11
Surge protection:	6kV/2 ohm combination wave, as per IEEE C62.41, line-line and line-ground
THD:	< 20%
Power factor:	> 0.9

Construction:

Housing:	Copper free aluminum
Finish:	Superior dual coat finish - Sealed polyester topcoat - Chemical-resistant epoxy primer
Lens :	Tempered glass

Photometric Information:

CRI:	75 80 min. option available
CCT:	5000K (cool white)
Beam patterns:	100° x 65° 95° 35°

IES files: Available at www.dialight.com

All values typical unless otherwise stated (tolerance +/- 10%)

¹For information on chemical compatibility, please follow this link to reference Dialight's Chemical Compatibility Guide: www.dialight.com/pubs/MDTFCHEMRFLX001.PDF

Vigilant® LED Floodlight - CE

Standard Models

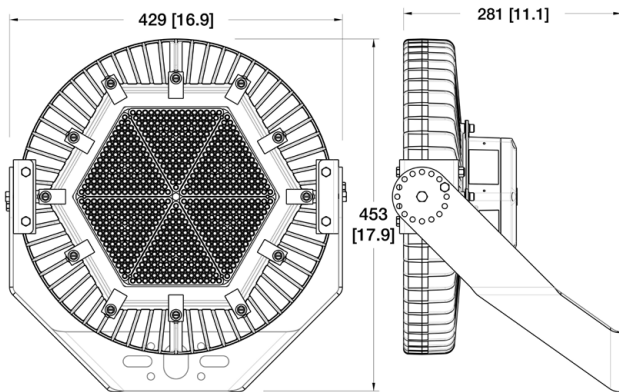

Dimensions in mm [inches]

Certifications & Ratings

- CE
EN 55015:2013
EN 61547:2009
EN 60598:2008
- IP66 to EN60529

Mechanical Information:

Fixture weight:	13.5 kg (30 lb)
Shipping weight:	18.5 kg (35 lb)
Mounting:	304 Stainless steel forward throw bracket
Entries:	(2) M20 cable entries

Electrical Specifications:

Operating voltage:	120 - 277V AC, 50/60Hz
Power consumption:	See table
Operating temp:	-40°C to +65°C (-40°F to +149°F)
Harmonics: :	EN 61000-3-2
Surge protection:	6kV/2 ohm combination wave, as per IEEE C62.41, line-line and line-ground
THD:	< 20%
Power factor:	> 0.9

Construction:

Housing:	Copper free aluminum
Finish:	Superior dual coat finish - Sealed polyester topcoat - Chemical-resistant epoxy primer
Lens :	Tempered glass

Photometric Information:

CRI:	75 80 min. option available
CCT:	5000K (cool white)
Beam patterns:	100° x 65° 95° 35°

IES files: Available at www.dialight.com

All values typical unless otherwise stated (tolerance +/- 10%)

For information on chemical compatibility, please follow this link to reference Dialight's Chemical Compatibility Guide:
www.dialight.com/pubs/MDTFCHEMRFLX001.PDF

Vigilant® LED Floodlight - CE

Mounting Accessories and Dimensions

Dial Floodlight Mounting Options

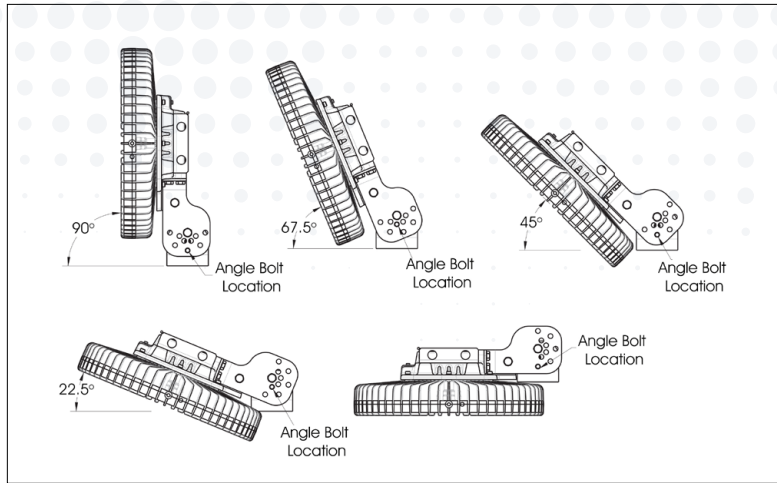
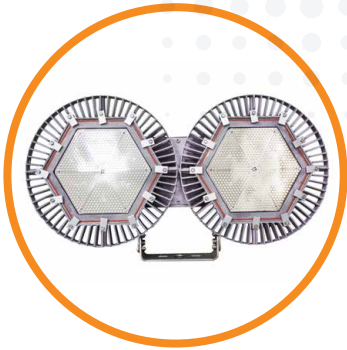

Factory installed mounting bracket dimensions

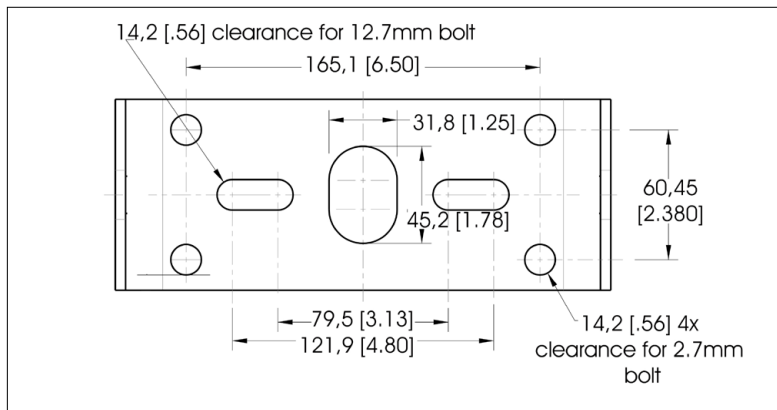

Dimensions in mm (inches)

Single Models

Factory installed mounting bracket dimensions

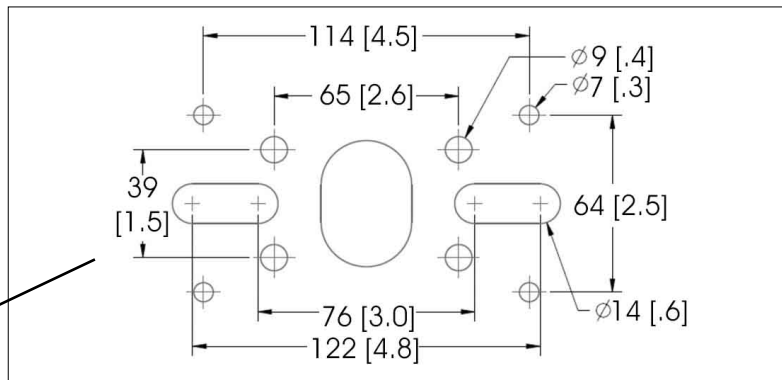

Dimensions in mm (inches)

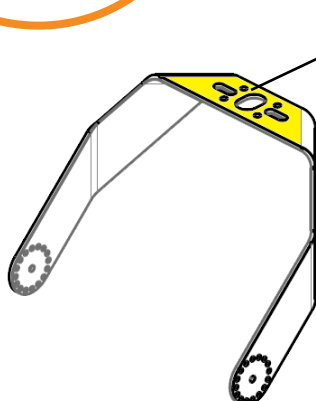

Vigilant® LED Floodlight - CE

Mounting Accessories



HZXCBL2

- Safety cable kit
- Kit includes: (2) Safety cables

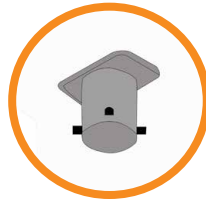

FLX-1TPT-20DB¹

- Tenon pole topper, 2-3/8" mount
- Kit includes: Tenon topper, pole set screws, and mounting hardware

¹Bracket and adapters require tenon adapter (FLX-1TPT-20DB) to mount floodlight. Tenon adapter is sold separately.

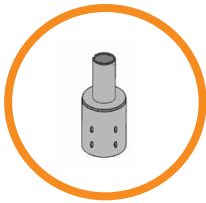

FLX-3RPA-20DB FLX-4RPA-20DB

- Reducer for 3" or 4" OD round pole top to 2-3/8" light mount
- Kit includes: Reducer pole set screws

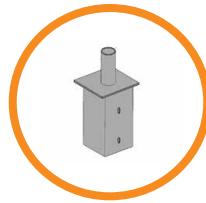

FLX-4SPA-20DB FLX-5SPA-20DB FLX-6SPA-20DB

- Internal tenon adapter for 4", 5" or 6" square pole top to 2-3/8" light mount
- Kit includes: Adapter

Vigilant® LED Floodlight - CE

Light Distribution Patterns

Beam Angle = 92°

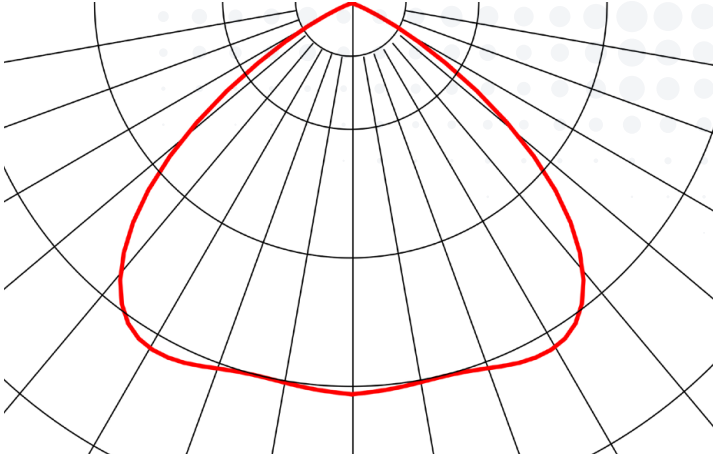

Beam Angle = 35°

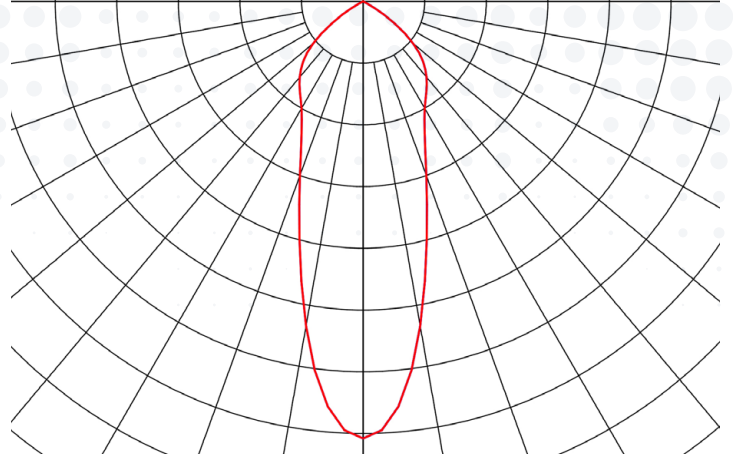

Beam Angle = 100° x 65°

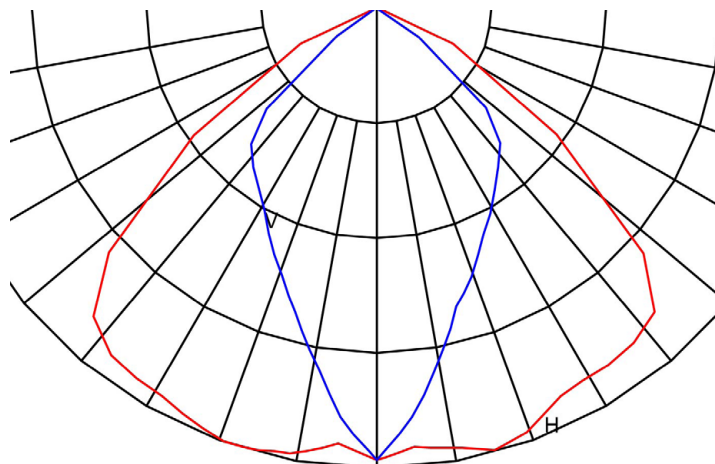

Vigilant® LED Floodlight - CE

Ordering Information

Part Number	Initial Fixture Lumens	Wattage	Lm/W	IP Rating	Voltage	Colour Temperature (CCT)	Lens	Beam Angle	Field Angle
Dual Floodlight Models									
FLEB66MC2NG	55,000	424	130	IP66	120 - 277V AC	5000K (cool white)	Clear Tempered Glass	35°	108°
FLEBM0MC2NG	53,000	424	125	IP66	120 - 277V AC	5000K (cool white)	Clear Tempered Glass	92°	120°
FLEB76MC2NG	51,000	408	125	IP66	120 - 277V AC	5000K (cool white)	Clear Tempered Glass	100° x 65°	135° x 105°
FLE966MC2NG	37,500	288	130	IP66	120 - 277V AC	5000K (cool white)	Clear Tempered Glass	35°	108°
Single Floodlight Models									
FLE666HC2NG	27,500	212	130	IP66	120 - 277V AC	5000K (cool white)	Clear Tempered Glass	35°	108°
FLE676HC2NG	25,500	204	125	IP66	120 - 277V AC	5000K (cool white)	Clear Tempered Glass	100° x 65°	135° x 105°

All values typical unless otherwise stated, Lumen values are typical (tolerance +/- 10%).

