

General Description

The M167 is a high performance microcontroller board based on the Infineon 16 Bit C167CR / CS microcontroller. The system provides a maximum of 512 kByte Flash and 1 MByte RAM memory.

With 2 independent CAN modules (C167CS only), 5 asynchronous serial interfaces and a high-speed synchronous serial channel, the M167 gives great connectivity to your application. An on board CAN transceiver allows direct connection to a CAN bus line according ISO11898.

Address- data- and control-busses and all C167 I/O lines are connected to high-density SMD connectors. This gives a very compact form factor with a board size of only 63 mm x 53 mm.

As special feature each M167 system has an individual serial number witch is readable by the controller.

In Circuit Programming is possible and will be done with the C167 internal boots trap loader via serial interface.

There is a wide application range just like PLC, embedded control or data communications. For OEM applications there is a version (EASY235) with the IEC-61131 programmable PLC operating system CoDeSys SP (3S) available.

For low cost applications, there are versions with only one serial interface and without real time clock available.



Top view

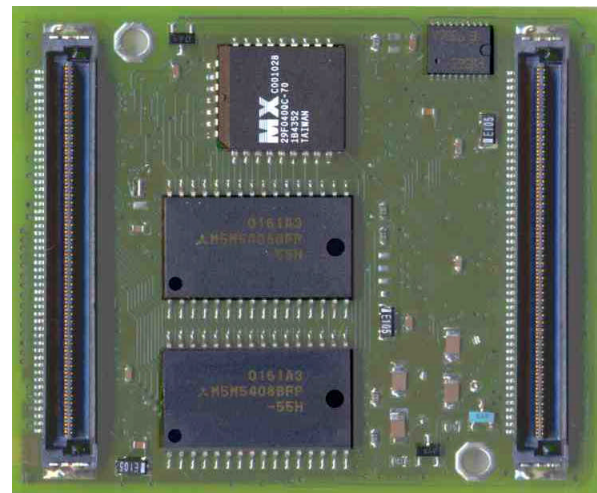

Bottom view

Features

- Microcontroller Infineon C167CR or C167CS
- Up to 40 MHz internal clock frequency
- Max. 512 kByte Flash (5V only)
- Max. 1 MByte RAM
- 5 free Chip Select signals for bus extension
- Watch Dog Timer
- 16-Channel 10 bit A/D Converter
- 4-Channel PWM Unit
- Two 16-Channel Capture/Compare Units
- Nine 16 bit Timers
- 2 CAN bus lines (C167CS)
- 5 serial interfaces (2 x RS232, 3 x TTL level)
- High speed synchronous serial interface
- Real Time Clock
- Silicon Serial Number
- Low Power design xxx mA
- Compact board design 64mm x 54mm
- High density SMD connector

Ordering Information

M167-Version

Part	Description
M167-CR24-S4	C167CR, 24 MHz CPU clock, 128 kByte Flash, 256 kByte RAM /FCI
M167-CR24-L4	C167CR, 24 MHz CPU clock, 512 kByte Flash, 1 Mbyte RAM /FCI
M167-CS24-S4	C167CS, 24 MHz CPU clock, 128 kByte Flash, 256 kByte RAM /FCI
M167-CS24-L4	C167CS, 24 MHz CPU clock, 512 kByte Flash, 1 Mbyte RAM /FCI
M167-EVA/FCI	Evaluation Board for M167
M167-CON/FCI	SMD-Connector for M167 boards 2 pieces needed

Other versions available on request

Pin Assignment

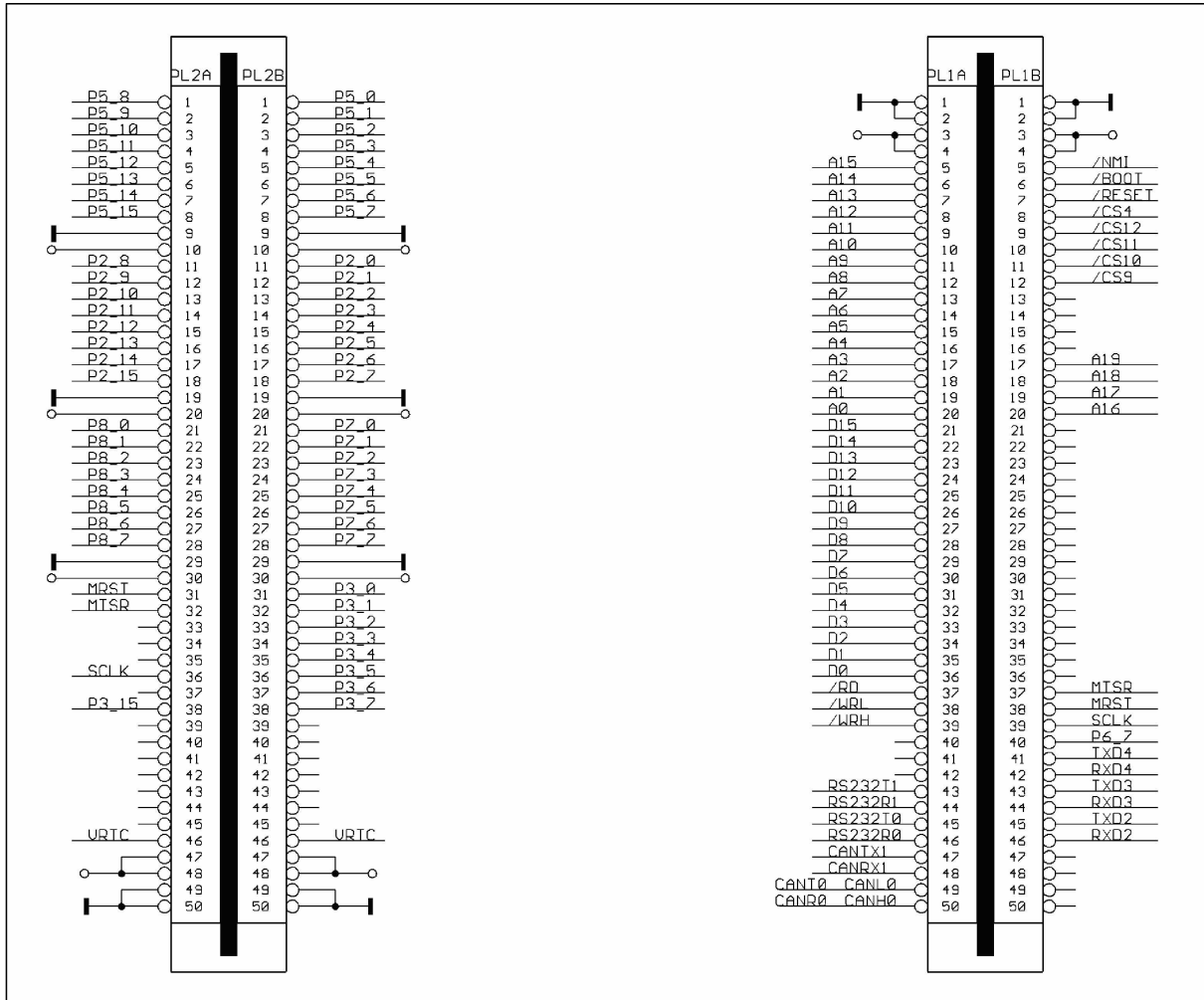

The Pinning shows the pin configuration from TOP view. Use this pinning on your application board.

Pin Listing (Plug PL1A)

PL1A		
Pin No.	Pin Name	Funktion
1, 2	GND	Ground
3, 4	VCC	5V Power Supply
5 to 20	A15 to A0	Address lines A15-A0
21 to 36	D15 to D0	Data lines
37	RD#	Read Signal
38	WRL#	Write Low Signal
39	WRH#	Write High Signal
40 to 42	nc	Not connected
43	RS232T1	Asynchronous Interface 1 Transmitter (RS232)
44	RS232R1	Asynchronous Interface 1 Receiver (RS232)
45	RS232T0	Asynchronous Interface 0 Transmitter (RS232)
46	RS232R0	Asynchronous Interface 0 Receiver (RS232)
47	CANTX1	CAN Interface Transmitter
48	CANRX1	CAN Interface Receiver
49	P4_6 / CANL0 / CANTX0	<i>J7 open:</i> Transmitter output of CAN module <i>On board CAN transceiver not used and J7 closed:</i> - Digital in- or output Port 4.5 - Signal CAN Rx (receive)
50	P4_5 / CANH0 / CANRX0	<i>J8 open:</i> - Receiver input of CAN module <i>On board CAN transceiver not used and J8 closed:</i> - Digital in- or output Port 4.6 - Signal CAN Tx (transmit)

Pin Listing (Plug PL1B)

PL1B		
Pin No.	Pin Name	Funktion
1, 2	GND	Ground
3, 4	VCC	5V Power Supply
5	NMI#	Non-Maskable Interrupt
6	BOOT#	Boots Trap Loader Input (active low)
7	RESET#	Reset in- or output
8	CS4#	External Chip Select 4
9 to 12	CS12# to CS9#	External Chip Select 12 to external Chip Select 9
13 to 16	nc	Not connected
17 to 20	A19 to A16	- Address lines A19-A16
21 to 36	nc	Not connected
37	P3_9 / MTSR	- Digital in- or output Port 3.9 - Synchronous serial interface Master transmit Slave receive
38	P3_8 / MRST	- Digital in- or output Port 3.8 - Synchronous serial interface Master receive Slave transmit
39	P3_13 / SCLK	- Digital in- or output Port 3.13 - Synchronous serial interface Shift clock in- or output
40	P6_7	- Digital in-/output Port 6.7
41	TXD4	Asynchronous Interface 4 transmitter
42	RXD4	Asynchronous Interface 4 receiver
43	TXD3	Asynchronous Interface 3 transmitter
44	RXD3	Asynchronous Interface 3 receiver
45	TXD2	Asynchronous Interface 2 transmitter
46	RXD2	Asynchronous Interface 2 receiver
47 to 50	nc	Not connected

Pin Listing (Plug PL2A)

PL2A		
Pin No.	Pin Name	Funktion
1 to 8	P5_8 to P5_15	- Digital input Port 5.8 to Port 5.15 - Analog/Digital Convert. 8-15 - Special Function Pins of Timer 2, 4, 5, 6 at Port 5.10-5.15
9	GND	Ground
10	VCC	5V Power Supply
11 to 18	P2_8 to P2_15	- Digital in-/output Port 2.8 to Port 2.15 - Capture in- or compare output 8-15 - Fast external Interrupt 0-7 - Timer 7 input at P2.15
19	GND	Ground
20	VCC	5V Power Supply
21 to 28	P8_0 to P8_7	- Digital in-/output Port 8.0 to Port 8.7 - Capture in- or compare output 16-23 - On Board Special Function Interrupt of async. serial Interface 1-4 (P8.4-P8.7)
29	GND	Ground
30	VCC	5V Power Supply
31	P3_8 / MRST	- Digital in- or output Port 3.8 - Synchronous serial interface Master receive Slave transmit
32	P3_9 / MTSR	- Digital in- or output Port 3.9 - Synchronous serial interface Master transmit Slave receive
33 to 35	nc	Not connected
36	P3_13 / SCLK	- Digital in- or output Port 3.13 - Synchronous serial interface Shift clock in- or output
37	nc	Not connected
38	P3_15	- Digital in- or output Port 3.9 - Clock Output
39 to 45	nc	Not connected
46	VRTC	Battery power supply input of Real Time Clock
47,48	VCC	5V Power Supply
49, 50	GND	Ground

Pin Listing (Plug PL2B)

PL2B		
Pin No.	Pin Name	Funktion
1 to 8	P5_0 to P5_7	- Digital input Port 5.0 to Port 5.7 - Analog/Digital Convert. 0-7
9	GND	Ground
10	VCC	5V Power Supply
11 to 18	P2_0 to P2_7	- Digital in-/output Port 2.0 to Port 2.7 - Capture in- or compare output 0-7
19	GND	Ground
20	VCC	5V Power Supply
21 to 28	P7_0 to P7_7	- Digital in-/output Port 7.0 to Port 7.7 - Capture in- or compare output 28-31 (P7.4-P7.7) - PWM output 0-7 (P7.0-P7.3)
29	GND	Ground
30	VCC	5V Power Supply
31 to 38	P3_0 to P3_7	- Digital in- or output Port 3.0 to Port 3.7 - Special Function Pins of Timer 0, 2, 3, 4, 6.
39 to 45	nc	Not connected
36	P3_13 / SCLK	- Digital in- or output Port 3.13 - Synchronous serial interface Shift clock in- or output
37	nc	Not connected
38	P3_15	- Digital in- or output Port 3.15 - Clock Output
39 to 45	nc	Not connected
46	VRTC	Battery power supply input of Real Time Clock
47,48	VCC	5V Power Supply
49, 50	GND	Ground

Pin Description

Most pins of the module are connected to the microcontroller directly. So refer for pins and the ports special functions, not described in this chapter, to the 'Infineon C167 Users Manual'. See chapter "Additional Literature". All manuals, data sheets and examples may be downloaded from our website.

VCC, GND: Power Supply Pins

Make sure that all ground and power supply pins are connected. VCC is +5V DC. Connect decoupling capacitors as close as possible to the device. See chapter "Recommended Operation Conditions" for details.

**Asynchronous Serial Interface ASC0
RS232T0, RS232R0: RS232-Interface**

The Asynchronous Serial Interface ASC0 provides serial communication between the M167 and other devices. The ASC0 is the C167 internal serial interface in additional with an RS232 level converter. It supports full-duplex asynchronous communication up to 220 kBaud.

On the M167 this interface is also used for the in circuit programming of the on board Flash memory using the boots trap loader of the C167 controller.

Boots Trap Mode: In boots trap mode, Pin BOOT# must be forced to low level during reset, the RS232T0 and RS232R0 pins are the transmitter and receiver pins of the asynchronous serial interface which is used for in circuit programming the M167 Flash memory.

The signals of these pins have RS232 levels. So if you need a connection to a PC or another RS232 device, only cable connection but no interface circuit is needed.

**Asynchronous Serial Interface ASC1
RS232T1, RS232R1:**

The Asynchronous Serial Interface ASC1 provides serial communication between the M167 and other devices. The ASC1 is one of 4 interfaces from the on board 16C554 communication chip that uses an 8-Bit data bus interface to the C167 microcontroller. 16C554 supports full-duplex asynchronous communication up to 115,2 kBaud. All signals of these pins have RS232 levels.

For using the interrupt mode of the ASC1, the jumper J6 must be closed and the interrupt of the capture compare channel 20 must be configured.

See 'Infineon C167 Users Manual' and '16C554 data sheet' for details.

For base address refer to table 'Peripheral Address Decoder'.

ASC1	No Interrupt	Interrupt Mode
J6	open	closed
P8.4	Extern available	On board used
Interrupt Unit	-	CC20
Request Flag	-	CC20IR
Enable Bit	-	CC20IE

**Asynchronous Serial Interface ASC2 to ASC4
TXDx, RXDx: (with x = 2 to 4)**

The Asynchronous Serial Interface ASCx provides serial communication between the M167 and other devices. The ASCx is one of 4 interfaces from the on board ST16C554 communication chip, that uses an 8-Bit data bus interface to the C167 microcontroller. 16C554 supports full-duplex asynchronous communication up to 115,2 Kbaud.

All signals of these pins have TTL levels. So if you need a connection to a PC or another RS232 device, you need an external RS232 driver circuit as shown in the following figure.

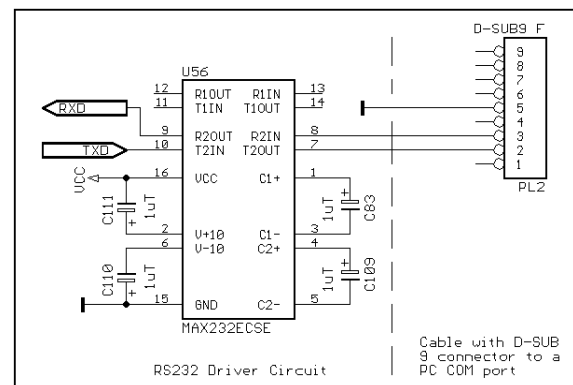

For using the interrupt mode of the ASCx, the corresponding interrupt output jumper must be closed and the interrupt of the corresponding capture compare channel must be configured.

ASC2	No Interrupt	Interrupt Mode
J5	open	closed
P8.5	Extern available	On board used
Interrupt Unit	-	CC21
Request Flag	-	CC21IR
Enable Bit	-	CC21IE

ASC3	No Interrupt	Interrupt Mode
J4	open	closed
P8.6	Extern available	On board used
Interrupt Unit	-	CC22
Request Flag	-	CC22IR
Enable Bit	-	CC22IE

ASC4	No Interrupt	Interrupt Mode
J3	open	closed
P8.7	Extern available	On board used
Interrupt Unit	-	CC23
Request Flag	-	CC23IR
Enable Bit	-	CC23IE

See 'Infineon C167 Users Manual' and '16C554 data sheet' for details.

For base address refer to table 'Peripheral Address Decoder'.

MRST, MTSR, SCLK: High-Speed Synchronous Serial Interface

The High-Speed Synchronous Serial Interface SSC provides flexible high-speed communication between the M167 and other microcontrollers. The SSC supports full-duplex and half-duplex communication up to 5 MBaud. The serial clock signal may be generated by the SSC itself (master mode) or be received from an external master (slave mode). Data width, clock polarity and phase are programmable. This allows communication with SPI compatible devices.

See 'Infineon C167 Users Manual' for details.

CANH0 / CANRX0, CANL0 / CANTX0: CAN Interface 0

The CAN Bus with its associated protocol allows communication between a number of stations which are connected to this bus with high efficiency. (Transfer speed up to 1 MBaud) The integrated CAN Module handles the transmission and reception of CAN frames in accordance with the CAN specification V2.0 part B (active) completely autonomous. The on-chip CAN module can receive and transmit standard frames with 11-bit identifiers as well as extended frames with 29-bit identifiers. It provides full CAN functionality. The CAN ground signal is connected to module ground.

M167 for external opto isolation:

The Version without using the on board CAN transceiver provides a user specific (opto isolated) CAN driver circuit at the application. Therefore the Jumpers J7 and J8 have to be set on position 2+3. In this condition the CANH0 pin is connected to signal CANRX0 and CANL0 to CANTX0 (TTL level).

M167 with using CAN transceiver:

With the on board CAN transceiver it is possible to connect the board directly to a two wire CAN bus associated to ISO11898. Jumper J7 and J8 must set to position 1+2.

Note: Before you connect the CAN interface of M167 to a CAN busline make sure, that Jumper J7 and J8 are set correctly. Wrong settings might cause permanent damage to the device.

RESET#: Reset input/output pin

The internal reset chip does the power up reset. It pulls the RESET# line low for more than 50 ms. So it is possible to reset external components during power up using this signal.

The reset pin can also be used as reset input. For a correct device reset by external components, force a low level longer than 50 ms to the input RESET#.

Note: Do never drive a low impedance high level to the RESET# pin. Use an open drain driver or a push button for this condition.

VRTC: Real Time Clock Battery Input

If a battery is connected to this pin, the clock is also running in power off mode of the M167. During normal operation the RTC is running with VCC power supply and the battery will not be discharged. The battery voltage range is given with 2,5V to 4,5V.

CS4#: Chip Select 4 Line

This Pin is directly connected to the CS4# output of the C167 microcontroller. It allows a free configuration of the external chip select signal via BUSCON4 and ADRSEL4 register pair. See 'Infineon C167 Users Manual' for details.

CS9# to CS12#: External Chip Select Line 9 to 12

This Chip Select Signals are generated with an 8 state address multiplexer and the controller chip select line CS3#. For details see 'Infineon C167 Users Manual' and the table 'Peripheral Address Decoder'.

For base address refer to table 'Peripheral Address Decoder'.

Peripheral Address Decoder

The active low chip select lines CS5# - CS12# are generated with an 8 state address multiplexer and the controllers internal chip select logic given by CS3# output. So it is necessary to configure the BUSCON3 and ADRSEL3 register pair. This configuration and in addition the multiplexer defines the address ranges of the chip select signals.

Recommended values:

BUSCON3 = xxxh
ADRSEL3 = xxxh

See 'Infineon C167 Users Manual' for details.

You can find tools and a standard startup file on the web site www.frenzel-berg.de.

CS (active low)	Unit	CS3#	A 18	A 17	A 16
CS5#	ASC4 (U12)	0	0	0	0
CS6#	ASC3 (U12)	0	0	0	1
CS7#	ASC2 (U12)	0	0	1	0
CS8#	ASC1 (U12)	0	0	1	1
CS9#	External (PL1B / 12)	0	1	0	0
CS10#	External (PL1B / 11)	0	1	0	1
CS11#	External (PL1B / 10)	0	1	1	0
CS12#	External (PL1B / 9)	0	1	1	1

On Chip Memory

The memory space of the M167 is configured in "Von Neumann" architecture. All memory elements will be selected by a chip select signal generated from the C167 internal chip select unit. The external bus is realized as none multiplexed bus. Therefore and for an optimized bus configuration the registers SYSCON, BUSCONx and ADRSELx must be loaded with the correct values during the start up.

Recommended values

SYSCON = xxxh

See 'Infineon C167 Users Manual' for details.

You can find tools and a standard startup file on the web site www.frenzel-berg.de.

U2, U3 External RAM Memory

The external RAM size is 256 kByte or 1 MByte depending on the module version and will be addressed by the C167 internal chip select line CS1. This size and the address space must be defined in the register ADDRSEL1. Signal timing and other bus access conditions must be set in the register BUSCON1. The external bus to the RAM memory is realized as a 16-Bit none multiplexed bus.

Recommended values

BUSCON1 = xxxh
ADRSEL1 = xxxh

The address rang for external RAM addressing is set with register ADDRSEL1. For smaller applications it is recommended to copy the complete code from external flash memory to RAM and then work only with RAM memory. This gives the advantage to use the same linker settings with your debugging tool and your release software. The start167.a66 file uses these settings.

U4 External Flash Memory

The external Flash size is 128 or 512 kByte depending on the module version and works with the C167 internal chip select CS0. The size and the address space you want to use for Flash memory must not be reserved by the register ADRSEL1 to ADRSEL4. Signal timing and other bus access conditions must be set in the register BUSCON0. The external bus to the Flash memory is realized as an 8-Bit none multiplexed bus.

Recommended values

BUSCON0 = xxxh

The Flash memory type is an AMD 29F010, AMD 29F040 or compatible types.

See 'Infineon C167 Users Manual' and 'AMD Flash Datasheet' for details

Internal XRAM Memory

The internal XRAM memory size is 4 KByte. The address range is E000H to EFFFH. See 'Infineon C167 Users Manual' for details.

Internal RAM Memory

The internal RAM memory size is 1 KByte. The address range is F600H to FFFFH. See 'Infineon C167 Users Manual' for details.

U12 Async. Serial Interface Controller

The 16C554 is an asynchronous serial interface controller with 4 identical communication ports. An 8-Bit data bus does the coupling to the mikrocontroller. Each of the 4 devices are using a several chip select signal and an address range of 8 Bytes.

For the base addresses refer to chapter 'Peripheral Address Decoder'.

For connections to the several interfaces refer to chapter 'Pin Description'.

See '16C554 data sheet for details and configurations.

U6 Silicon Serial Number

The U6 is a DALAS DS2401 silicon serial number. Its internal ROM is accessed via a single data line. The 48-bit serial number, an 8-bit family code and an 8-bit CRC are retrieved using the DALAS 1-Wire protocol. This protocol defines bus transactions in terms of bus state during specified time slots that are initiated on the falling edge of sync pulses from the bus master. See 'DALAS DS2401 Datasheet' for details.

You can find a C-Source code example for reading out the serial number on our website www.frenzel-berg.de.

Jumper Settings

Jumper	Setting	Prescription
J1	open	External bus access (default)
	closed	Single chip mode
J2	1-2	RAM-type 2 x 512 kByte
	3-2	RAM-type 2 x 128 kByte
J3	open	P8.7 free for external use
	closed	P8.7 used for SIO INT1
J4	open	P8.6 free for external use
	closed	P8.6 used for SIO INT2
J5	open	P8.5 free for external use
	closed	P8.5 used for SIO INT3
J6	open	P8.4 free for external use
	closed	P8.4 used for SIO INT4
J7	1-2	Signal CANH0 on PL1A Pin 50
	3-2	Signal CANR0 on PL1A Pin 50
J8	1-2	Signal CANL0 on PL1A Pin 49
	3-2	Signal CANT0 on PL1A Pin 49

Top View

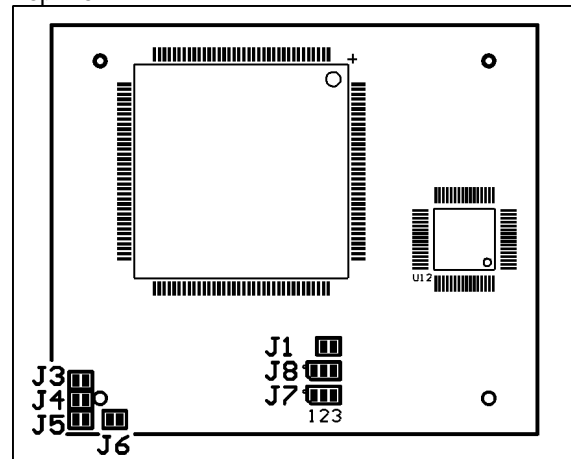

Bottom View

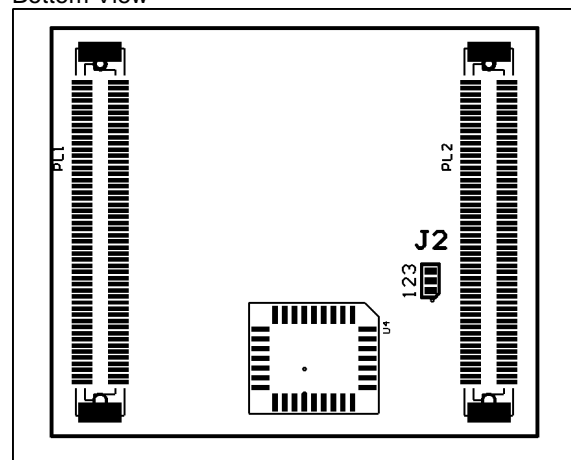

Software-Download

Use the Software FlashJet for downloading your application software to the M167's Flash memory.

The FlashJet software uses the C167's integrated boots trap loader. For activation of the boot mode, the Pin 6 of PL1B (Boot#) must pulled down to GND during reset.

Steps for download:

- 1) Connect your application board to a serial interface of your PC.
- 2) Provide power supply to your application board
- 3) Start FlashJet software on your PC
- 4) Select file to download
- 5) Pull down signal BOOT# to GND level
- 6) Reset M167
- 7) Start download on FlashJet software
- 8) After download remove GND level from signal BOOT#
- 9) After the next reset the M167 will start the downloaded program

Download the FlashJet software from our web site www.frenzel-berg.de for free.

Additional Literature

- SAB-C167 Users Manual (Infineon)
- 29C040 Data Sheet (AMD)
- DS2401 Data Sheet (DALLAS)
- RTC8563 Data Sheet (EPSON)
- 16C554 Data Sheet (EXAR)

Absolute Maximum Ratings

Stresses greater than those listed parameters may cause permanent damage to the device. Functional operation should be restricted to recommended operation conditions. Exposure to absolute maximum rating conditions for extended times may affect reliability.

Parameter	Symbol	Rated Value		Units	Remarks
		Min.	Max.		
Power supply voltage	VCC	VSS – 0.3	VSS + 6.0	V	
Analog power supply voltage	AVCC	VSS – 0.3	VCC	V	
Analog reference voltage	AVREF	VSS – 0.3	VCC	V	
Input voltage	Vi	VSS – 0.3	VSS + 6.0	V	Vi < VCC + 0.3V
Output voltage	Vo	VSS – 0.3	VSS + 6.0	V	Vo < VCC + 0.3V
L level maximum output current	IOLMAX			mA	Time < 20 msec
L level maximum output current	IOL			mA	
H level maximum output current	IOHMAX			mA	Time < 20 msec
H level maximum output current	IOH			mA	
Maximum Power dissipation	P _{MAX}			mW	
Operating temperature	T _A	0	+70	°C	
	T _A	-40	+105	°C	On request
Storing temperature	T _A	-55	+150	°C	

Recommended Operation Conditions and Characteristics

Functional operation should be restricted to recommended operation conditions.

Parameter	Symbol	Rated Value			Units	Remarks
		Min.	Typ.	Max.		
Power supply voltage	VCC	4.5	5.0	5.5	V	
Analog power supply voltage	AVCC			VCC	V	
Analog reference voltage	AVREF			VCC	V	
Power supply current	I _{CC}				mA	All inputs V _{IL} or V _{IH} All outputs open
Input H voltage	V _{IH}	0.8 * VCC		VCC + 0.3	V	
Input L voltage	V _{IL}	VSS – 0.3		0.2 * VCC	V	
Output H voltage	V _{OH}	VCC – 0.5			V	I _{OH} =
Output L voltage	V _{OL}			0.4	V	I _{OL} =
Input leakage current	I _{LKC}	-5		5	uA	
Crystal frequency	f _{osc}				MHz	
Reset pulse width	t _{res}	100			us	
Power on rise time	t _{RESLH}	0.05		60	ms	
Maximum Power dissipation	P _{MAX}				mW	
Operating temperature	T _A	0		+70	°C	Standard Module
	T _A	-40		+105	°C	On request

Mechanical Dimensions

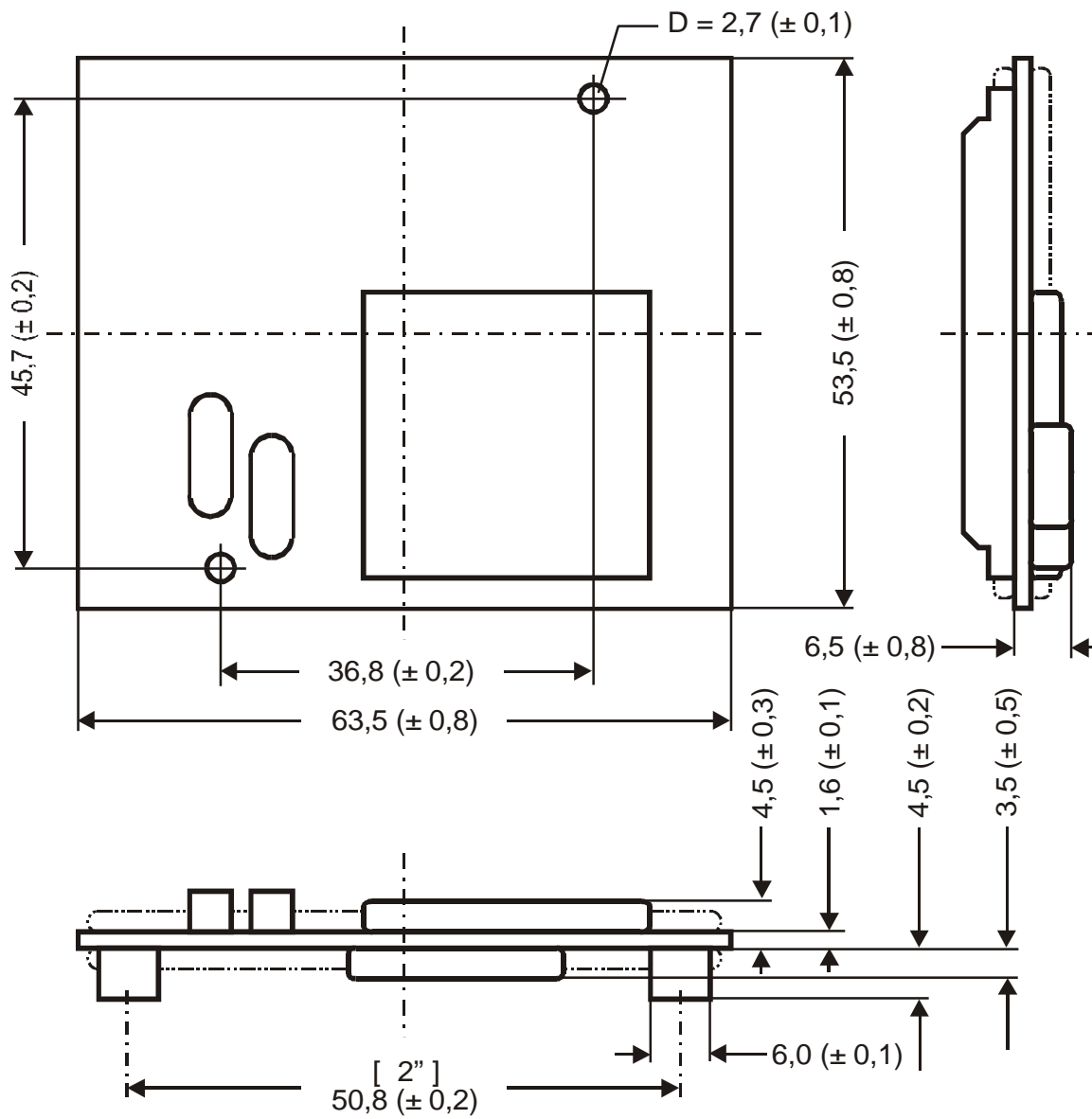

Place plan

Top view

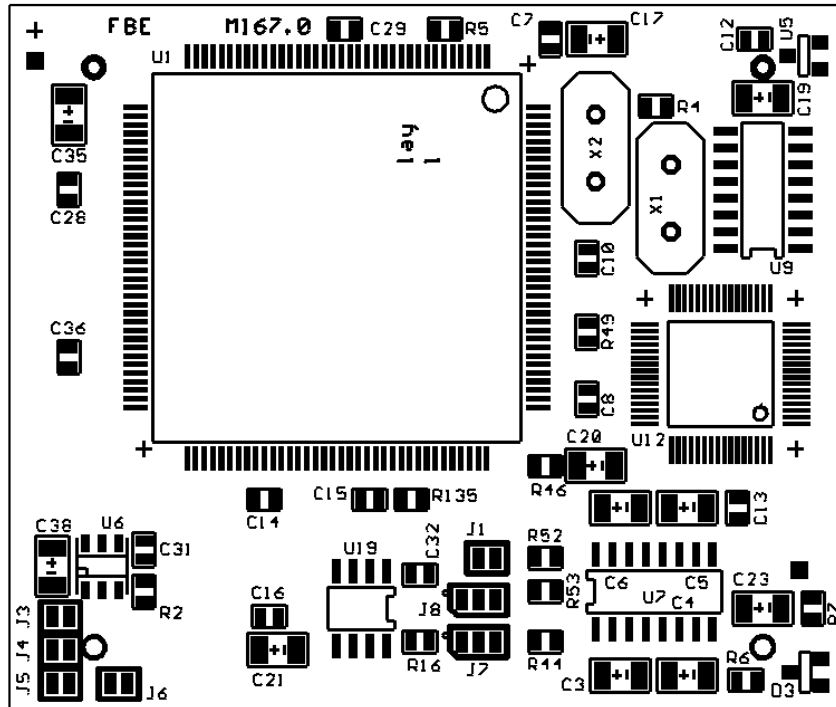

Bottom view

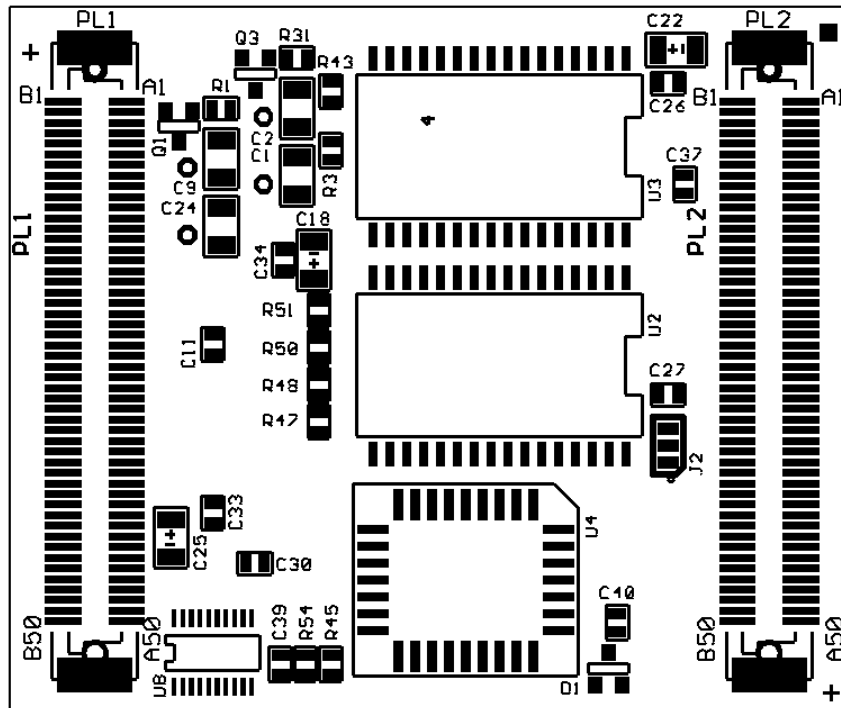

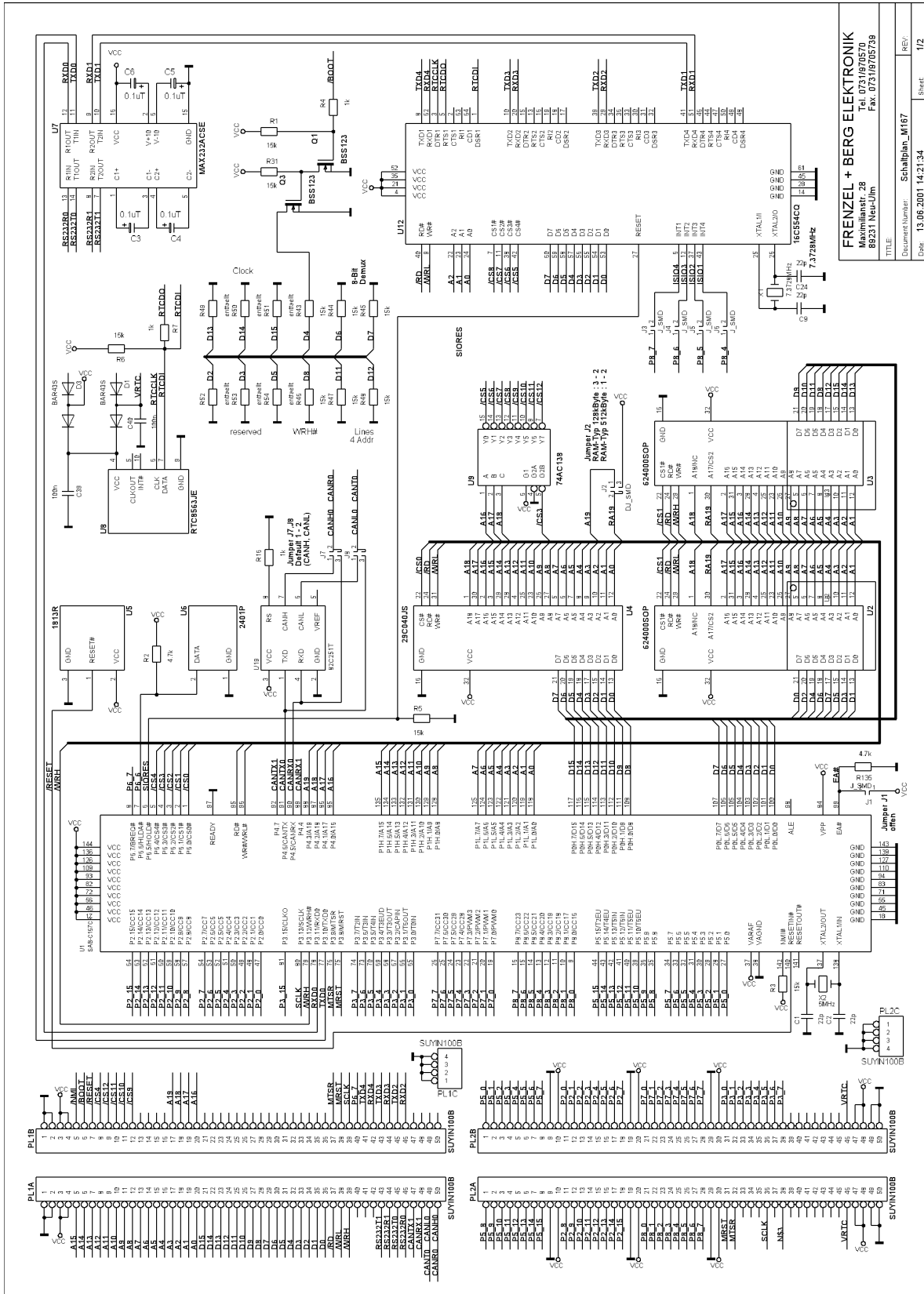

FRENZEL + BERG ELEKTRONIK
Maximiliansstr. 28
88231 Neu-Ulm
Tel. 0731/90570
Fax: 0731/905739

Document Number: Schaltung_M167
Date: 13.08.2001 14:21:34
Sheet: 1/2

General Description	1
Features	1
Ordering Information	1
Pin Assignment	2
Pin Listing (Plug PL1A)	3
Pin Listing (Plug PL1B)	3
Pin Listing (Plug PL2A)	4
Pin Listing (Plug PL2B)	4
Pin Description	5
VCC, GND: Power Supply Pins	5
Asynchronous Serial Interface ASC0 RS232T0, RS232R0: RS232-Interface	5
Asynchronous Serial Interface ASC1 RS232T1, RS232R1:	5
Asynchronous Serial Interface ASC2 to ASC4 TXDx, RXDx: (with x = 2 to 4)	5
MRST, MTSR, SCLK: High-Speed Synchronous Serial Interface	6
CANH0 / CANRX0, CANL0 / CANTX0: CAN Interface 0	6
RESET#: Reset input/output pin	6
VRTC: Real Time Clock Battery Input	6
CS4#: Chip Select 4 Line	6
CS9# to CS12#: External Chip Select Line 9 to 12	6
Peripheral Address Decoder	7
On Chip Memory	7
U2, U3 External RAM Memory	7
U4 External Flash Memory	7
Internal XRAM Memory	8
Internal RAM Memory	8
U12 Async. Serial Interface Controller	8
U6 Silicon Serial Number	8
Jumper Settings	8
Software-Download	9
Additional Literature	9
Absolute Maximum Ratings	10
Recommended Operation Conditions and Characteristics	10
Mechanical Dimensions	11
Place plan	12