

Allgemein

Das hipecs-CIO150 ist ein kostengünstiges CANopen Modul mit 8 analogen Eingängen und 4 analogen Ausgängen. Die E/A's sind galvanisch vom Bussystem und der Versorgung getrennt. Die Ausgänge sind kurzschlussfest.

In diesem E/A-Modul sind die komplexen CANopen-Standards DS301 und DS401 implementiert. Alle üblichen Baudraten bis zu 1 Mbit werden unterstützt.

Funktionen

- CANopen remote I/O Module entsprechend den CiA Draft Standards DS301 Version 4.0 und DS401 Version 2.0
- Spannungsversorgung für System/Bus und Ein-/Ausgänge (DC24V)
- 8 analoge Eingänge galvanisch isoliert von Bus und Spannungsversorgung, 16 Bit Auflösung
- Eingangsspannungsbereiche: 0...+10V, -10 ...+10V
- 4 analoge Ausgänge galvanisch vom Bus und Spannungsversorgung getrennt, Kurzschlussstrom 20mA, 12 Bit Auflösung
- Ausgangsspannungsbereiche: 0...+10 V, -10...+10V, 0...+5V, -5...+5V
- CAN-Baudraten bis 1Mbit
- CAN-Bus ISO11898 mit Transceiver TJA1050
- 4 Transmit und 4 Receive PDOs
- Dynamisches PDO Mapping
- Variable PDO Identifier
- CANopen PDO Übertragungsmodi: synchron, asynchron, ereignisgesteuert, zyklisch, azyklisch und Remote Frame bezogen.
- Event Timer und Inhibit Timer für alle Transmit PDOs.
- Nodeguarding, Lifeguarding und Heartbeat
- Emergency Nachrichten
- Minimum boot up
- Kunststoffgehäuse zum Aufrasten auf DIN-Trageschienen
- Betriebstemperatur 0 bis 55°C (opt. -40...+70°C)

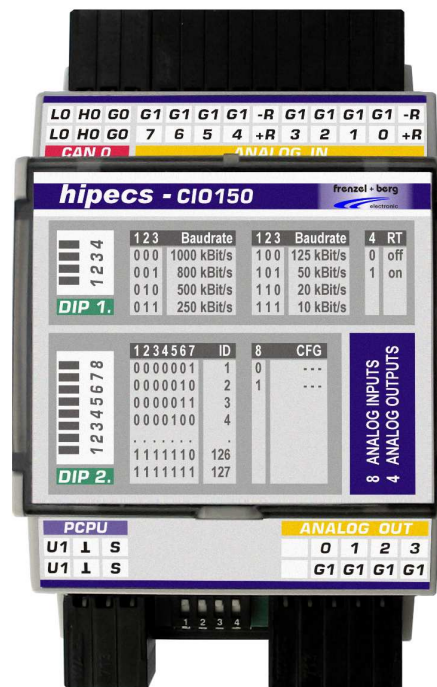

Bestellinformation

Bauteil	Best.-Nr.	Beschreibung
hipecs-CIO150-i	EZ.00000. 2205.00	8/4 analoge Ein- / Ausgänge CAN galvanisch entkoppelt, 0...55°C
hipecs-CIO150-ie	EZ.00000. 3150.00	8/4 analoge Ein- / Ausgänge CAN galvanisch entkoppelt, -40...70°C

Technische Daten

Spannungsversorgung System	Min.	Norm.	Max.
Nominale System/Bus Versorgungsspannung	11 V	24 V	32 V
CAN bus Norm	ISO11898		
CiA Draft Standards	DS301 Version 4.0 und DS401 Version 2.0		
Isolation zwischen Bus und System / Vcc	60 V		
Konformitätserklärung	CE		

Analoge Eingänge	
Anzahl Eingänge	8
max. negative Eingangsspannung	-10 Volt
max. positive Eingangsspannung	+10 Volt
max. zulässige Spannung an den Eingängen	+/- 60 Volt
Verzögerungszeit (CAN reaction time)	2 ms (typisch < 1ms)
Auflösung	16 bit
Isolation zum Bus/System	60 V

Analoge Ausgänge	
Anzahl Ausgänge	4
Kurzschlussfest	ja
Auflösung	12 Bit
Verzögerungszeit (CAN reaction time)	2 ms (typisch < 1ms)
max. Ausgangsstrom bei Kurzschluss für alle Kanäle	20 mA
max. Ausgangsstrom pro Kanal	5 mA (minimale Ausgangslast größer 2 kOhm bei Spannungsbereich – 10..+10V / 0..+10V)
max Kapazität am Ausgang	4nF

Referenzgänge	
Anzahl Referenzgänge	2 x +10Volt / 2 x –10 Volt
max. Ausgangsstrom Referenzgänge	10 mA

Stecker und Abmessungen	
Stecker	WAGO Steckverbinder Typ 713 (Im Lieferumfang enthalten)
Leitungsquerschnitt [mm²]	0,08 bis 1,5 mm²
Leitungsquerschnitt [AWG]	14 bis 28 AWG
Leiterlänge	7 mm
Abmessung CIO150 Gehäuse	ca. 125 x 54 x 62 mm (Bild "Abmessungen" beachten!)
Betriebstemperatur	0 .. 55°C (opt. -40...+70°C)

Steckerbelegung X1 (CAN)

Pin Nr.	Name	Funktion
1	G0	CAN Ground
2	G0	CAN Ground
3	H0	CAN High Signal
4	H0	CAN High Signal
5	L0	CAN Low Signal
6	L0	CAN Low Signal

Steckerbelegung X4 (Analog Output)

Pin Nr.	Name	Funktion
1	n.b.	nicht belegt
2	n.b.	nicht belegt
3	G1	Masse für Analogausgänge
4	AOUT 0	Analogausgang 0
5	G1	Masse für Analogausgänge
6	AOUT 1	Analogausgang 1
7	G1	Masse für Analogausgänge
8	AOUT 2	Analogausgang 2
9	G1	Masse für Analogausgänge
10	AOUT 3	Analogausgang 3

Steckerbelegung X2 (analoge Eingänge)

Pin Nr.	Name	Funktion
1	R-	Referenzspannung -10 Volt
2	R+	Referenzspannung +10 Volt
3	G1	Masse für Analogeingänge
4	AIN 0	Analogeingang 0
5	G1	Masse für Analogeingänge
6	AIN 1	Analogeingang 1
7	G1	Masse für Analogeingänge
8	AIN 2	Analogeingang 2
9	G1	Masse für Analogeingänge
10	AIN 3	Analogeingang 3
11	R-	Referenzspannung -10 Volt
12	R+	Referenzspannung +10 Volt
13	G1	Masse für Analogeingänge
14	AIN 4	Analogeingang 4
15	G1	Masse für Analogeingänge
16	AIN 5	Analogeingang 5
17	G1	Masse für Analogeingänge
18	AIN 6	Analogeingang 6
19	G1	Masse für Analogeingänge
20	AIN 7	Analogeingang 7

Steckerbelegung X3 (PCPU Versorgung)

Pin Nr.	Name	Funktion
1	U1	Versorgungsspannung DC 24V für System / Bus
2	U1	Versorgungsspannung DC 24V für System / Bus
3	GND	Masse für System / Bus
4	GND	Masse für System / Bus
5	S	Schirmung/Shield
6	S	Schirmung/Shield

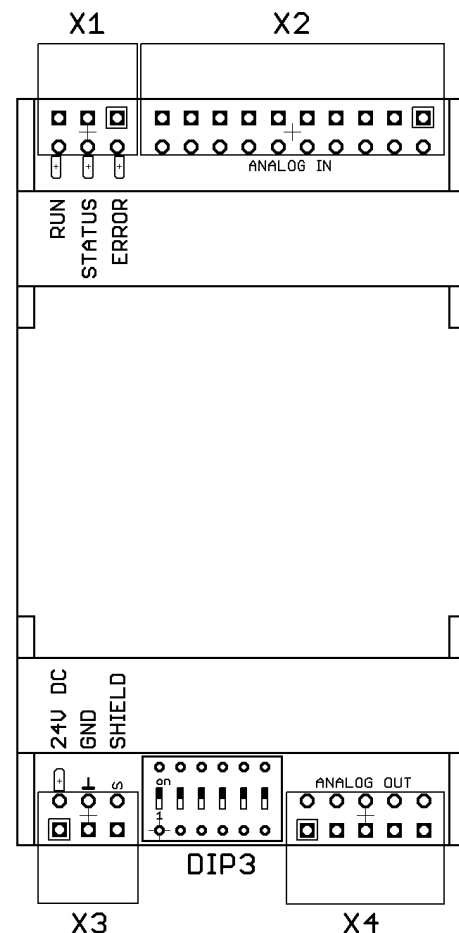

Ansicht von oben

Konfiguration Dip-Schalter

DIP1 und DIP2 am Einstellmodul

DIP Switch DIP1 (Einstellung Baudrate)				
Switch Nummer				Funktion
1	2	3	4	
BD2	BD1	BD0	RT	
X	X	X	ON	CAN-Terminierung ein (120 Ohm)
X	X	X	OFF	CAN-Terminierung aus
OFF	OFF	OFF	X	1 Mbit / sec
OFF	OFF	ON	X	800 kbit / sec
OFF	ON	OFF	X	500 kbit / sec
OFF	ON	ON	X	250 kbit / sec
ON	OFF	OFF	X	125 kbit / sec
ON	OFF	ON	X	50 kbit / sec
ON	ON	OFF	X	20 kbit / sec
ON	ON	ON	X	10 kbit / sec

DIP Switch DIP2 (Einstellung Knotennummer)								
Switch Nummer								Funktion
1	2	3	4	5	6	7	8	
0	0	0	0	0	0	1	X	Node ID = 1
0	0	0	0	0	1	0	X	Node ID = 2
0	0	0	0	1	1	1	X	Node ID = 3
0	0	0	0	1	0	0	X	Node ID = 4
.	X
1	1	1	1	1	1	0	X	Node ID = 126
1	1	1	1	1	1	1	X	Node ID = 127
X	X	X	X	X	X	X	ON	Configuration (reserviert für zukünftige Anwendungen)
X	X	X	X	X	X	X	OFF	Configuration (reserviert für zukünftige Anwendungen)

SW3 auf dem Board

DIP Switch SW3 (Einstellung Spannungsbereich)				
Switch Nummer				Funktion
1	2	3	4	
X	X	X	ON	Input range -10..+10 Volt
X	X	X	OFF	Input range 0..+10 Volt
X	OFF	OFF	X	Output range 0 .. +10 Volt
X	OFF	ON	X	Output range 0 .. 5 Volt
X	ON	OFF	X	Output range -10 .. +10 Volt
X	ON	ON	X	Output range -5 .. +5 Volt
ON	X	X	X	Wert in Millivolt übertragen
OFF	X	X	X	Wert als Hexwert übertragen

CAN Signal LED's

LED	Farbe	Funktion
RUN-LED	grün	Die RUN-LED zeigt den NMT-Zustand entsprechend DRP303-3 an Aus Flackern 1x flashen (kurzes Aufblitzen) Blinken ein Betriebsspannung fehlt oder Defekt CAN noch nicht gestartet Stopped Preoperational Operational
ERROR-LED	rot	Die Error-LED zeigt den Fehlerzustand entsprechend DRP303-3 an aus 1x flashen 2x flashen ein Kein Fehler CAN-Modul ist im Error-Warning-Zustand Node-Guarding-Fehler Bus-Off-Zustand des Knoten
STATUS-LED	gelb	Die gelbe Status LED zeigt weitere Fehler an 3x flashen blinken an noch keine boot-up Nachricht gesendet unkritischer Fehler / kein NMT-Wechsel kritischer Fehler / NMT state gewechselt

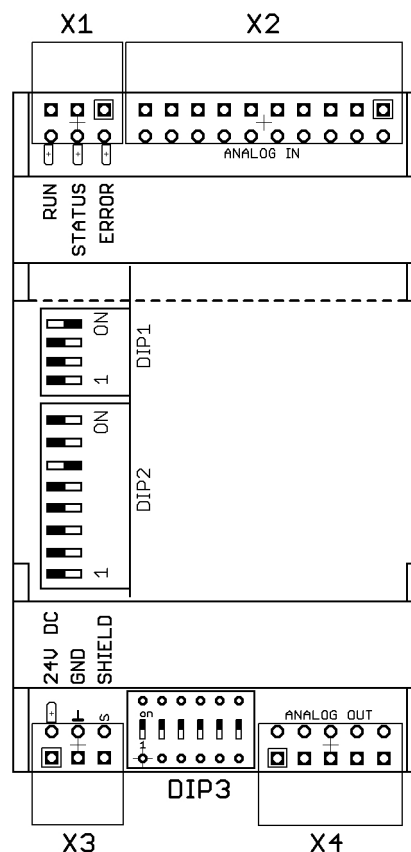

Ansicht von oben (Deckel geöffnet)
(DIP1 und DIP2 im Gehäuse, DIP3 von außen zugänglich)

Prinzipschaltbild analoge Eingänge

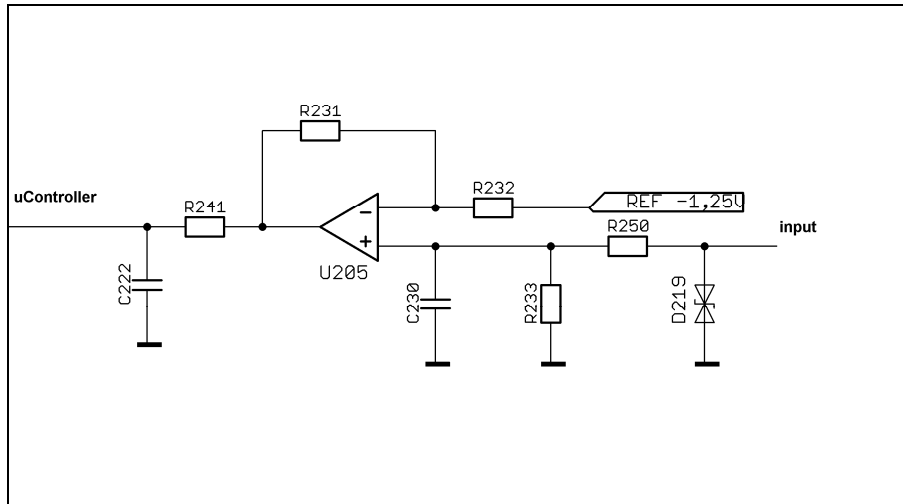

Prinzipschaltbild analoge Ausgänge

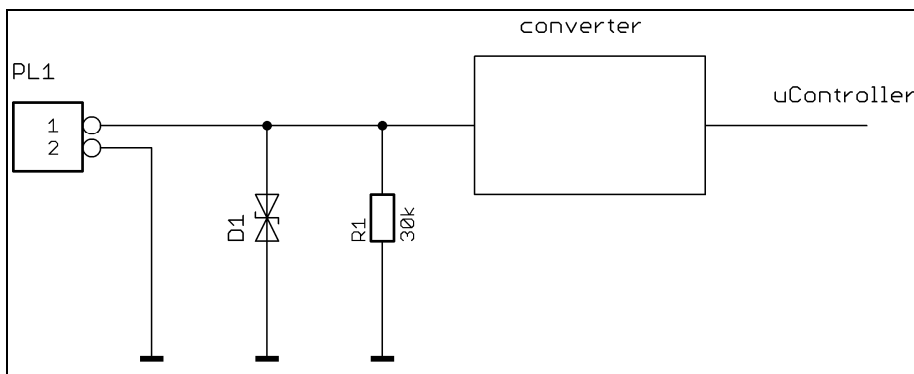

Abmessungen Kunststoffgehäuse

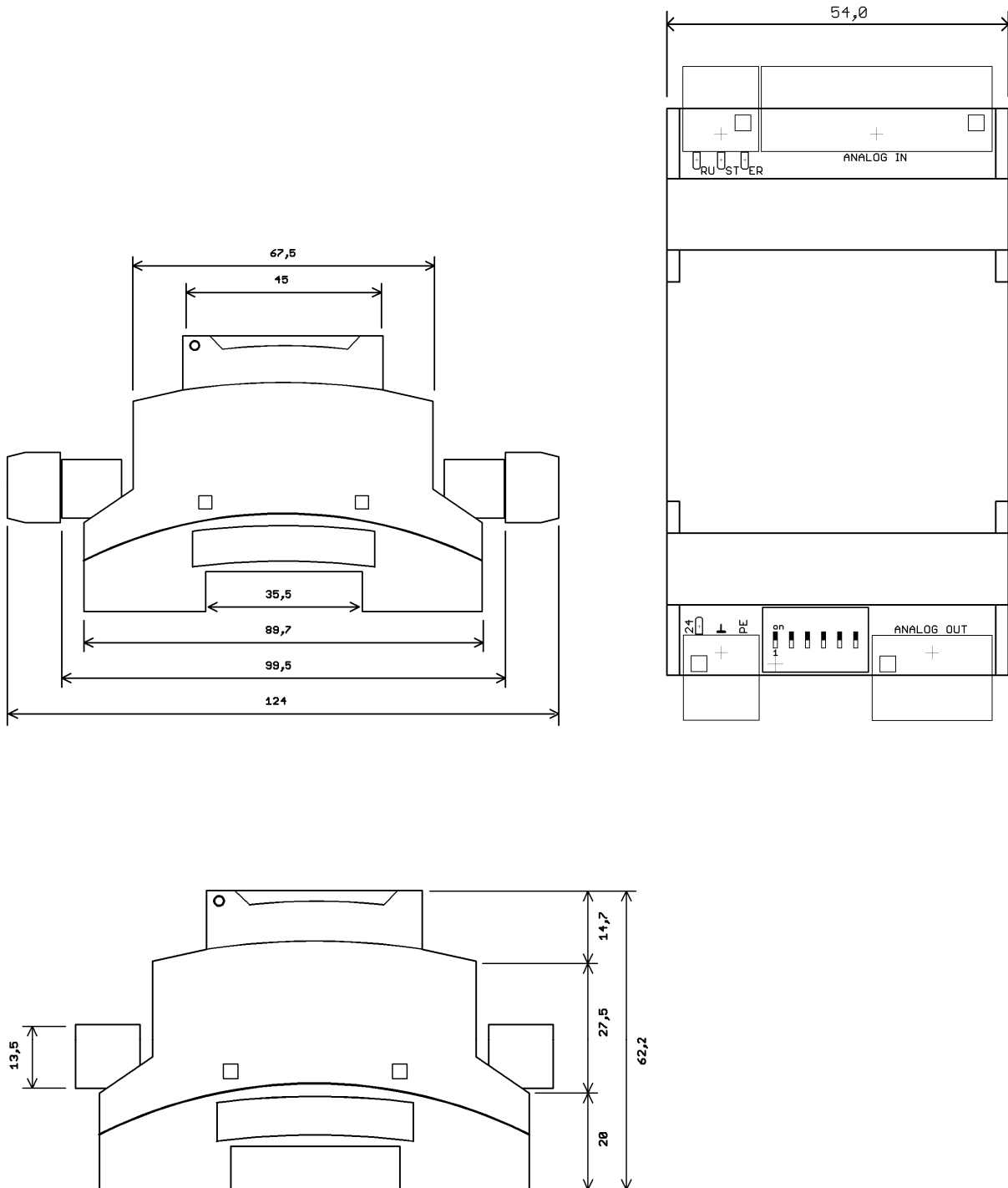

Alle Maße in mm

CANopen Objektverzeichnis

Im hipecs-CIO150 Controller ist das komplexe Objektverzeichnis für CANopen E/A-Geräte implementiert.

Hipecs-CIO150 Objekte

Alle Werte dieser Tabelle sind in hexadezimaler Schreibweise notiert.

Als Zugriffsberechtigungen sind folgende Typen definiert:

ro read only / nur lesen

wo write only / nur schreiben

rw read and write access enabled / lesen und schreiben

rww read and write access enabled by SDO, write only by PDO / lesen, schreiben per SDO, PDO nur schreiben

Index	Sub-Index	Name	Data type	Acc.	Map-pable	Default Value / Note	Object Category
1000	-	Device Type	Unsigned 32	ro	no	0003 0191 h	Global
1001	-	Error Register	Unsigned 8	ro	yes	-	Global
1002	-	Manufacturer Status Register	Unsigned 32	ro	yes	-	Global
1005	-	COB-ID Sync Identifier Sync Object	Unsigned 32	ro	no	80 h	Global
1008	-	Device Name	Visible String	ro	no	"hipecs-CIO150"	Global
1009	-	Hardware Version	Visible String	ro	no	-	Global
100A	-	Software Version	Visible String	ro	no	active Version	Global
100C	-	Guard Time	Unsigned 16	rw	no	0 h	Global
100D	-	Life Time Factor	Unsigned 8	rw	no	0 h	Global
1014	-	COB ID Emergency	Unsigned 32	rw	no	80 h + Node-ID	Global
1015	-	Inhibit Time Emergency	Unsigned 16	rw	no	0 h (disabled)	Global
1016		Consumer Heartbeat Time	Array	-	no	-	Global
	0	Nr of Subobjects	Unsigned 8	ro	no	04 h	Global
	1	Consumer Heartbeat Time 1	Unsigned 32	rw	no	0 h	Global
	2	Consumer Heartbeat Time 2	Unsigned 32	rw	no	0 h	Global
	3	Consumer Heartbeat Time 3	Unsigned 32	rw	no	0 h	Global
	4	Consumer Heartbeat Time 4	Unsigned 32	rw	no	0 h	Global
1017	-	Producer Heartbeat Time	Unsigned 16	rw	no	0 h	Global
1018		Identity Object	Record	-	-	-	Global
	0	Nr of Subobjects	Unsigned 8	ro	no	04 h	Global
	1	Vendor ID	Unsigned 32	ro	no	0000 0058 h	Global
	2	Product Code	Unsigned 32	ro	no	0301 5000 h	Global
	3	Revision Number	Unsigned 32	ro	no	active Rev. Code	Global
	4	Serial Number	Unsigned 32	ro	no	-	Global
1029		Error Behavior Object	Array	-	-	-	Global
	0	Nr of Subobjects	Unsigned 8	ro	no	2 h	Global
	1	Communication error	Unsigned 8	rw	no	0 h	Global
	2	Application error	Unsigned 8	rw	no	0 h	Global
1400		Receive PDO0 - Communication Parameters	Record	-	-	-	PDO
	0	Nr of Subobjects	Unsigned 8	ro	no	2 h	PDO
	1	COB-ID	Unsigned 32	rw	no	0x80000200 + Node-ID	PDO
	2	Transmission Type	Unsigned 8	rw	no	FF h	PDO
1401		Receive PDO1 - Communication Parameters	Record	-	-	-	PDO
	0	Nr of Subobjects	Unsigned 8	ro	no	2 h	PDO
	1	COB-ID	Unsigned 32	rw	no	300 + Node-ID	PDO
	2	Transmission Type	Unsigned 8	rw	no	FF h	PDO

Index	Sub-Index	Name	Data type	Acc.	Map-pable	Default Value / Note	Object Category
1402		Receive PDO2 - Communication Parameters	Record	-	-	-	PDO
	0	Nr of Subobjects	Unsigned 8	ro	no	2 h	PDO
	1	COB-ID	Unsigned 32	rw	no	0x80000400 + Node-ID	PDO
	2	Transmission Type	Unsigned 8	rw	no	FF h	PDO
1403		Receive PDO3 - Communication Parameters	Record	-	-	-	PDO
	0	Nr of Subobjects	Unsigned 8	ro	no	2 h	PDO
	1	COB-ID	Unsigned 32	rw	no	0x80000500 h + Node-ID	PDO
	2	Transmission Type	Unsigned 8	rw	no	FF h	PDO
1600		Receive PDO0 - Mapping Parameters	Record	-	-	-	PDO
	0	Nr of Subobjects	Unsigned 8	rw	no	0 h	PDO
1601		Receive PDO1 - Mapping Parameters	Record	-	-	-	PDO
	0	Nr of Subobjects	Unsigned 8	rw	no	4 h	PDO
	1	Mapped Object	Unsigned 32	rw	no	6411 01 10 h analog AOUT0	PDO
	2	Mapped Object	Unsigned 32	rw	no	6411 02 10 h analog AOUT1	PDO
	3	Mapped Object	Unsigned 32	rw	no	6411 03 10 h analog AOUT2	PDO
	4	Mapped Object	Unsigned 32	rw	no	6411 04 10 h analog AOUT3	PDO
1602		Receive PDO2 - Mapping Parameters	Record	-	-	-	PDO
	0	Nr of Subobjects	Unsigned 8	rw	no	0 h	PDO
1603		Receive PDO3 - Mapping Parameters	Record	-	-	-	PDO
	0	Nr of Subobjects	Unsigned 8	rw	no	0 h	PDO
1800		Transmit PDO0 - Communication Parameters	Record	-	-	-	PDO
	0	Nr of Subobjects	Unsigned 8	ro	no	5 h	PDO
	1	COB-ID	Unsigned 32	rw	no	0x80000180 h + Node-ID	PDO
	2	Transmission Type	Unsigned 8	rw	no	FF h	PDO
	3	Inhibit Time	Unsigned 16	rw	no	0 h	PDO
	4	Compatibility Entry	Unsigned 8	rw	no	-	PDO
	5	Event Time	Unsigned 16	rw	no	0 h	PDO
1801		Transmit PDO1 - Communication Parameters	Record	-	-	-	PDO
	0	Nr of Subobjects	Unsigned 8	ro	no	5 h	PDO
	1	COB-ID	Unsigned 32	rw	no	280 h + Node-ID	PDO
	2	Transmission Type	Unsigned 8	rw	no	FF h	PDO
	3	Inhibit Time	Unsigned 16	rw	no	0 h	PDO
	4	Compatibility Entry	Unsigned 8	rw	no	-	PDO
	5	Event Time	Unsigned 16	rw	no	0 h	PDO

Index	Sub-Index	Name	Data type	Acc.	Map- pable	Default Value / Note	Object Category
1802		Transmit PDO2 - Communication Parameters	Record	-	-	-	PDO
	0	Nr of Subobjects	Unsigned 8	ro	no	5 h	PDO
	1	COB-ID	Unsigned 32	rw	no	380 h + Node-ID	PDO
	2	Transmission Type	Unsigned 8	rw	no	FF h	PDO
	3	Inhibit Time	Unsigned 16	rw	no	0 h	PDO
	4	Compatibility Entry	Unsigned 8	rw	no	-	PDO
	5	Event Time	Unsigned 16	rw	no	0 h	PDO
1803		Transmit PDO2 - Communication Parameters	Record	-	-	-	PDO
	0	Nr of Subobjects	Unsigned 8	ro	no	5 h	PDO
	1	COB-ID	Unsigned 32	rw	no	80000480 h + Node-ID	PDO
	2	Transmission Type	Unsigned 8	rw	no	FF h	PDO
	3	Inhibit Time	Unsigned 16	rw	no	0 h	PDO
	4	Compatibility Entry	Unsigned 8	rw	no	-	PDO
	5	Event Time	Unsigned 16	rw	no	0 h	PDO
1A00		Transmit PDO0 – Mapping Parameters	Record	-	-	-	PDO
	0	Nr of Subobjects	Unsigned 8	rw	no	0 h	PDO
1A01		Transmit PDO1 – Mapping Parameters	Record	-	-	-	PDO
	0	Nr of Subobjects	Unsigned 8	rw	no	4 h	PDO
	1	Mapped Object	Unsigned 32	rw	no	6401 01 10 h analog AIN0	PDO
	2	Mapped Object	Unsigned 32	rw	no	6401 02 10 h analog AIN1	PDO
	3	Mapped Object	Unsigned 32	rw	no	6401 03 10 h analog AIN2	PDO
	4	Mapped Object	Unsigned 32	rw	no	6401 04 10 h analog AIN3	PDO
1A02		Transmit PDO2 – Mapping Parameters	Record	-	-	-	PDO
	0	Nr of Subobjects	Unsigned 8	rw	no	4 h	PDO
	1	Mapped Object	Unsigned 32	rw	no	6401 05 10 h analog AIN4	PDO
	2	Mapped Object	Unsigned 32	rw	no	6401 06 10 h analog AIN5	PDO
	3	Mapped Object	Unsigned 32	rw	no	6401 07 10 h analog AIN6	PDO
	4	Mapped Object	Unsigned 32	rw	no	6401 08 10 h analog AIN7	PDO
1A03		Transmit PDO3 – Mapping Parameters	Record	-	-	-	PDO
	0	Nr of Subobjects	Unsigned 8	rw	no	0 h	PDO
2000	-	Device Manufacturer	Visible String	ro	no	"FRENZEL+BERG"	Global
2009		Serial Number 64 Bit	Array	-	-	-	Global
	0	Nr of Subobjects	Unsigned 8	ro	no	2 h	Global
	1	Serial Number 64 Bit LSDW	Unsigned 32	ro	no	-	Global
	2	Serial Number 64 Bit MSDW	Unsigned 32	ro	no	-	Global
2101	-	System Configuration	Unsigned 32	ro	no	Setting of Config. Input Pins	Global
2102	-	Remapping Enabled Info	Unsigned 8	ro	no	1 h (enabled)	Global
2103	-	Enable Guarding Warning	Unsigned 8	rw	no	0 h (disabled)	Global
2105	-	Internal API State	Unsigned 32	ro	yes	-	Global

Index	Sub-Index	Name	Data type	Acc.	Map-pable	Default Value / Note	Object Category
2110	-	Conformance Test Object	Record	-	-		Global
	0	Nr of Subobjects	Unsigned 8	ro	no	1 h	Global
	1	Range Check Object	Unsigned 16	rw	no	500	Global
2180	-	CAN Restart Time	Unsigned 16	rw	no	1000 h (restart after one second)	Global
5301		Analog Input Filter Level	Unsigned 16	rw	no	10	Global
5310		Input Scaling	Record	-	-		Global
	0	Nr of Subobjects	Unsigned 8	ro	no	4 h	Global
	1	Input Scaling Key	Unsigned 32	rw	no	0 h	Global
	2	Input Scaling Command	Unsigned 32	wo	no	0 h	Global
	3	Input Scaling Result	Unsigned 16	ro	no		Global
	4	Input Scaling Step	Unsigned 16	ro	no		Global
6401	-	Analog Input 16bit	Array	-	-		Global
	0	Nr of Subobjects	Unsigned 8	ro	no	8 h	Global
	1	Analog Input 16bit1	Integer 16	ro	yes		Global
	2	Analog Input 16bit2	Integer 16	ro	yes		Global
	3	Analog Input 16bit3	Integer 16	ro	yes		Global
	4	Analog Input 16bit4	Integer 16	ro	yes		Global
	5	Analog Input 16bit5	Integer 16	ro	yes		Global
	6	Analog Input 16bit6	Integer 16	ro	yes		Global
	7	Analog Input 16bit7	Integer 16	ro	yes		Global
8	Analog Input 16bit8	Integer 16	ro	yes		Global	
6411		Analog Output 16bit	Array	-	-		Global
	0	Nr of Subobjects	Unsigned 8	ro	no	4 h	Global
	1	Analog Output 16bit1	Integer 16	rww	yes		Global
	2	Analog Output 16bit2	Integer 16	rww	yes		Global
	3	Analog Output 16bit3	Integer 16	rww	yes		Global
6421		Ana. Input Trigger Selection	Array	-	-		Global
	0	Nr of Subobjects	Unsigned 8	ro	no		Global
	1	Ana. Input Trigger Selection1	Unsigned 8	rw	no	7 h	Global
	2	Ana. Input Trigger Selection2	Unsigned 8	rw	no	7 h	Global
	3	Ana. Input Trigger Selection3	Unsigned 8	rw	no	7 h	Global
	4	Ana. Input Trigger Selection4	Unsigned 8	rw	no	7 h	Global
	5	Ana. Input Trigger Selection5	Unsigned 8	rw	no	7 h	Global
	6	Ana. Input Trigger Selection6	Unsigned 8	rw	no	7 h	Global
	7	Ana. Input Trigger Selection7	Unsigned 8	rw	no	7 h	Global
8	Ana. Input Trigger Selection8	Unsigned 8	rw	no	7 h	Global	
6423		Analog Input Interrupt Enable	Unsigned 8	rw	no		Global
6424		Ana Input Interrupt Upper L.	Array	-	-		Global
	0	Nr of Subobjects	Unsigned 8	ro	no	8 h	Global
	1	Ana. Input Irq Upper Limit1	Integer 32	rw	no	0 h	Global
	2	Ana. Input Irq Upper Limit2	Integer 32	rw	no	0 h	Global
	3	Ana. Input Irq Upper Limit3	Integer 32	rw	no	0 h	Global
	4	Ana. Input Irq Upper Limit4	Integer 32	rw	no	0 h	Global
	5	Ana. Input Irq Upper Limit5	Integer 32	rw	no	0 h	Global
	6	Ana. Input Irq Upper Limit6	Integer 32	rw	no	0 h	Global
	7	Ana. Input Irq Upper Limit7	Integer 32	rw	no	0 h	Global
8	Ana. Input Irq Upper Limit8	Integer 32	rw	no	0 h	Global	

Index	Sub-Index	Name	Data type	Acc.	Map-pable	Default Value / Note	Object Category
6425		Ana Input interrupt Lower L.	Array	-	-		Global
	0	Nr of Subobjects	Unsigned 8	ro	no	8 h	Global
	1	Ana. Input Irq Lower Limit1	Integer 32	rw	no	0 h	Global
	2	Ana. Input Irq Lower Limit2	Integer 32	rw	no	0 h	Global
	3	Ana. Input Irq Lower Limit3	Integer 32	rw	no	0 h	Global
	4	Ana. Input Irq Lower Limit4	Integer 32	rw	no	0 h	Global
	5	Ana. Input Irq Lower Limit5	Integer 32	rw	no	0 h	Global
	6	Ana. Input Irq Lower Limit6	Integer 32	rw	no	0 h	Global
	7	Ana. Input Irq Lower Limit7	Integer 32	rw	no	0 h	Global
6426		Ana Input interrupt Delta	Array	-	-		Global
	0	Nr of Subobjects	Unsigned 8	ro	no	8 h	Global
	1	Ana. Input Interrupt Delta 1	Integer 32	rw	no	0 h	Global
	2	Ana. Input Interrupt Delta 2	Integer 32	rw	no	0 h	Global
	3	Ana. Input Interrupt Delta 3	Integer 32	rw	no	0 h	Global
	4	Ana. Input Interrupt Delta 4	Integer 32	rw	no	0 h	Global
	5	Ana. Input Interrupt Delta 5	Integer 32	rw	no	0 h	Global
	6	Ana. Input Interrupt Delta 6	Integer 32	rw	no	0 h	Global
	7	Ana. Input Interrupt Delta 7	Integer 32	rw	no	0 h	Global
6427		Ana Input interrupt Neg. Delta	Array	-	-		Global
	0	Nr of Subobjects	Unsigned 8	ro	no	8 h	Global
	1	Ana. Input Irq Neg. Delta 1	Integer 32	rw	no	0 h	Global
	2	Ana. Input Irq Neg. Delta 2	Integer 32	rw	no	0 h	Global
	3	Ana. Input Irq Neg. Delta 3	Integer 32	rw	no	0 h	Global
	4	Ana. Input Irq Neg. Delta 4	Integer 32	rw	no	0 h	Global
	5	Ana. Input Irq Neg. Delta 5	Integer 32	rw	no	0 h	Global
	6	Ana. Input Irq Neg. Delta 6	Integer 32	rw	no	0 h	Global
	7	Ana. Input Irq Neg. Delta 7	Integer 32	rw	no	0 h	Global
6428		Ana Input interrupt Pos. Delta	Array	-	-		Global
	0	Nr of Subobjects	Unsigned 8	ro	no	8 h	Global
	1	Ana. Input Irq Pos. Delta 1	Integer 32	rw	no	0 h	Global
	2	Ana. Input Irq Pos. Delta 2	Integer 32	rw	no	0 h	Global
	3	Ana. Input Irq Pos. Delta 3	Integer 32	rw	no	0 h	Global
	4	Ana. Input Irq Pos. Delta 4	Integer 32	rw	no	0 h	Global
	5	Ana. Input Irq Pos. Delta 5	Integer 32	rw	no	0 h	Global
	6	Ana. Input Irq Pos. Delta 6	Integer 32	rw	no	0 h	Global
	7	Ana. Input Irq Pos. Delta 7	Integer 32	rw	no	0 h	Global
6443		Analog Output Error Mode	Array	-	-		Global
	0	Nr of Subobjects	Unsigned 8	ro	no	4 h	Global
	1	Analog Output Error Mode1	Unsigned 8	rw	no	1 h	Global
	2	Analog Output Error Mode2	Unsigned 8	rw	no	1 h	Global
	3	Analog Output Error Mode3	Unsigned 8	rw	no	1 h	Global
6444		Analog Output Error Value	Array	-	-		Global
	0	Nr of Subobjects	Integer 32	ro	no	4 h	Global
	1	Analog Output Error Value1	Integer 32	rw	no	0 h	Global
	2	Analog Output Error Value2	Integer 32	rw	no	0 h	Global
	3	Analog Output Error Value3	Integer 32	rw	no	0 h	Global
	4	Analog Output Error Value4	Integer 32	rw	no	0 h	Global

Bemerkung: DS301 PDO Parameter Objekte

Beschreibung der PDO-Parameter-Objekte

Diese Objekte ermöglichen ein dynamisches PDO-Mapping, variable PDO-Identifizier Einstellungen, das Einstellen der Übertragungsmodi, sowie inhibit und event time Konfiguration.

Die Einstellungen für diese CIO150 Parameter können alle im CANopen-Zustand „operational“, als auch im Zustand „pre-operational“ erfolgen.

Description of Object Dictionary

The following list gives a short description of all dictionary entries, available for the hipecs-CIO series of CANopen I/O modules.

Index 0005

This object is implemented to enable reservation of data space in PDOs by mapping dummy entries.

Index	0005
Name	Dummy 8
Description	
Data Type	Unsigned 8
Access modes	RO
PDO Mapping	Yes
Value Range	-
Default Value	0

Index 0006

This object is implemented to enable reservation of data space in PDOs by mapping dummy entries.

Index	0006
Name	Dummy 16
Description	-
Data Type	Unsigned 16
Access modes	RO
PDO Mapping	Yes
Value Range	-
Default Value	0

Index 0007

This object is implemented to enable reservation of data space in PDOs by mapping dummy entries.

Index	0007
Name	Dummy 32
Description	-
Data Type	Unsigned 32
Access modes	RO
PDO Mapping	Yes
Value Range	-
Default Value	0

DS301: Global Objects

Index 1000 : Device Type

Description of the device type. The Object gives the CiA device profile number and additionally the functionality of the device.

Index	1000h
Name	Device Type
Description	-
Data Type	Unsigned 32
Access modes	RO
PDO Mapping	No
Value Range	-
Default Value	see device datasheet

Index 1001 : Error Register

This object holds an error of the device.

Index	1001h
Name	Error Register
Description	-
Data Type	Unsigned 8
Access modes	RO
PDO Mapping	Yes
Value Range	-
Default Value	-

The error register has the following structure

Bit	Meaning
0	Generic error. This bit is set, if any error is active
1	0
2	0
3	0
4	CAN bus or communication error
5	0
6	0
7	Device Error

Index 1002 : Status Register

This object gives additional information for the device

Index	1002h
Name	Status Register
Description	-
Data Type	Unsigned 32
Access modes	RO
PDO Mapping	Yes
Value Range	-
Default Value	-

Index 1005 : COB-ID Sync

Identifier of Can Object for the Synchronisation message. The hipecs-CIO may only operate in Sync consumer mode. Generating of Sync messages is not possible. Therefore the Identifier for the Sync message can only be set to the value range 1 .. 7FFh.

Index	1005h
Name	COB-ID Sync
Description	-
Data Type	Unsigned 32
Access modes	RW
PDO Mapping	No
Value Range	1 .. 7FFh
Default Value	80h

Index 1008 : Device Name

This object shows the name of the device as visible string.

Index	1008h
Name	Device Name
Description	-
Data Type	Visible String
Access modes	RO
PDO Mapping	No
Value Range	The maximum string length is 20 characters
Default Value	"hipecs-CIO150"

Index 1009 : Hardware Version

This object shows the hardware version and firmware version as visible string.

Index	1009h
Name	Hardware Version
Description	-
Data Type	Visible String
Access modes	RO
PDO Mapping	No
Value Range	The maximum string length is 20 characters
Default Value	-

Index 100A : Software Version

This object shows the software version as visible string.

Index	100Ah
Name	Software Version
Description	-
Data Type	Visible String
Access modes	RO
PDO Mapping	No
Value Range	The maximum string length is 20 characters
Default Value	-

Index 100C : Guard Time

The objects at index 100Ch (Guard Time in milliseconds) and 100Dh (Life Time Factor) are used to implement the life guarding protocol. The Guard Time multiplied with the Life Time Factor gives the Life Time in milliseconds.

It is 0 (zero) if not used.

Index	100Ch
Name	Guard Time
Description	-
Data Type	Unsigned 16
Access modes	RW
PDO Mapping	No
Value Range	
Default Value	0

Index 100D : Life Time Factor

The objects at index 100Ch (Guard Time in milliseconds) and 100Dh (Life Time Factor) are used to implement the life guarding protocol. The Guard Time multiplied with the Life Time Factor gives the Life Time in milliseconds.
It is 0 (zero) if not used.

Index	100Dh
Name	Life Time Factor
Description	-
Data Type	Unsigned 8
Access modes	RW
PDO Mapping	No
Value Range	
Default Value	0

Index 100E : COB-ID Guard

Identifier of Can Object for the Node Guarding protocol. The Object is not represented in the object dictionary because of standard conforming reasons.

Index	100Eh
Name	COB-ID Guard
Description	-
Data Type	Unsigned 32
Access modes	-
PDO Mapping	No
Value Range	-
Default Value	700h + Node-ID

Index 1014 : COB-ID Emergency

Identifier of Can Object for the emergency messages.

Index	1014h
Name	COB-ID Emergency
Description	-
Data Type	Unsigned 32
Access modes	RW
PDO Mapping	No
Value Range	-
Default Value	80h + Node-ID

Index 1015 : Inhibit Time Emergency

Inhibit Time for emergency messages. If the Inhibit Time is set to 0, inhibit delay is disabled. The Inhibit Time is a multiple of 100usec, but the hipecs-CIO offers a maximum resolution of 1 millisecond.

Index	1015h
Name	Inhibit Time Emergency
Description	-
Data Type	Unsigned 16
Access modes	RW
PDO Mapping	No
Value Range	-
Default Value	0

Index 1016 : Consumer Heartbeat Time

The objects of Index 1016 are used to define the consumer heartbeat times for up to 4 nodes. With each sub index, the configuration for one monitored node can be set.

Index	1016h
Name	Consumer Heartbeat Time
Description	-
Data Type	Structure

Index	1016h Subindex 0
Name	Largest SubIndex supported
Description	-
Data Type	Unsigned 8
Access modes	RO
PDO Mapping	No
Value Range	-
Default Value	4

Index	1016h Subindex 1
Name	Consumer Heartbeat Time 1
Description	-
Data Type	Unsigned 32
Access modes	RW
PDO Mapping	No
Value Range	-
Default Value	0

Index	1016h Subindex 2
Name	Consumer Heartbeat Time 2
Description	-
Data Type	Unsigned 32
Access modes	RW
PDO Mapping	No
Value Range	-
Default Value	0

Index	1016h Subindex 3
Name	Consumer Heartbeat Time 3
Description	-
Data Type	Unsigned 32
Access modes	RW
PDO Mapping	No
Value Range	-
Default Value	Revision of the device

Index	1016h Subindex 4
Name	Consumer Heartbeat Time 4
Description	-
Data Type	Unsigned 32
Access modes	RW
PDO Mapping	No
Value Range	-
Default Value	0

Structure of consumer heartbeat time:

MSB				LSB
Byte3	Byte2	Byte1	Byte0	
reserved	Node-ID	Heartbeat time		

Note:

Monitoring of the heartbeat producer starts after the reception of the first heartbeat.
 The consumer heartbeat time should be higher than the corresponding producer heartbeat time.
 Before the reception of the first heartbeat the status of the heartbeat producer is unknown.

Index 1017 : Producer Heartbeat Time

The producer heartbeat time defines the cycle time of the heartbeat. The producer heartbeat time is 0 if it is not used. The time has to be a multiple of 1ms.

Index	1017h
Name	Producer Heartbeat Time
Description	-
Data Type	Unsigned 16
Access modes	RW
PDO Mapping	No
Value Range	-
Default Value	0

Note:

Either Heartbeat or node guarding may be allowed at the same time. Do not use both protocols at the same time.

Index 1018 : Identity Object

The object at index 1018h keeps general information about the device and the manufacturer frenzel + berg electronic. It cannot be modified.

Index	1018h
Name	Identity Object
Description	-
Data Type	Structure

Index	1018h Subindex 0
Name	Largest SubIndex supported
Description	-
Data Type	Unsigned char
Access modes	RO
PDO Mapping	No
Value Range	-
Default Value	4

Index	1018h Subindex 1
Name	Vendor ID
Description	Registration Code of frenzel + berg electronic at the CiA
Data Type	Unsigned 32
Access modes	RO
PDO Mapping	No
Value Range	-
Default Value	58h

Index	1018h Subindex 2
Name	Product Code
Description	Internal Product Code hipecs-CIO at frenzel + berg elektronik
Data Type	Unsigned 32
Access modes	RO
PDO Mapping	No
Value Range	-
Default Value	see device datasheet

Index	1018h Subindex 3
Name	Revision Code
Description	
Data Type	Unsigned 32
Access modes	RO
PDO Mapping	No
Value Range	-
Default Value	Revision of the device

Index	1018h Subindex 4
Name	Serial Number
Description	
Data Type	Unsigned 32
Access modes	RO
PDO Mapping	No
Value Range	-
Default Value	0

Index 1029 : Error Behaviour

With object 1029 the CANopen chip can be configured to enter alternatively the preoperational or the stopped state or remain in the current state in case of a device failure. Device failures shall include the following communication errors:

Bus-off conditions of the CAN interface, Life guarding error, Serious device errors also can be caused by device internal failures.

The value of the Error Classes is as follows:

- 0 = pre-operational
(only if current state is operational)
- 1 = no state change
- 2 = stopped
- 3 .. 127 = reserved

Index	1029h
Name	Error Behaviour Object
Description	-
Data Type	Structure

Index	1029h Subindex 0
Name	Largest SubIndex supported
Description	-
Data Type	Unsigned char
Access modes	RO
PDO Mapping	No
Value Range	-
Default Value	2

Index	1029h Subindex 1
Name	Communication Error
Description	NMT state change in case of communication error
Data Type	Unsigned 8
Access modes	RW
PDO Mapping	No
Value Range	-
Default Value	00h

Index	1029h Subindex 2
Name	Application Error
Description	NMT state change in case of internal error due to hardware malfunction
Data Type	Unsigned 8
Access modes	RW
PDO Mapping	No
Value Range	-
Default Value	00h

DS301: PDO Parameter Objects

Communication Parameter Objects

The following table shows the communication parameter objects for Index 140x (Receive PDOs) and Index 180x (Transmit PDOs). The tables show Index 1400 as an example for all PDOs

The transmission type (sub-index 2) defines the mode for transmission / reception of the PDO. See table for detailed description of this entry.

Description of transmission type:

Type	PDO transmission				
	cyclic	acyclic	Sync related	Async.	Only on remote
0		X	X		
1-240	X		X		
241-251	Reserved				
252			X		X
253				X	X
254				X	
255				X	

Synchronous transmission types 0-240 and 252 mean that the transmission of the PDO shall be related to the SYNC object. Asynchronous means that the transmission of the PDO is not related to the SYNC object.

A transmission type of zero means that the message shall be transmitted synchronously with the SYNC object but not periodically but only in case of data change.

A value between 1 and 240 means that the PDO is transferred synchronously and cyclically, the transmission type indicating the number of SYNC signals, which are necessary to trigger PDO transmissions or receptions.

The transmission types 252 and 253 mean that the PDO is only transmitted on reception of a remote frame. At transmission type 252, the data is updated (but not sent) immediately after reception of the SYNC object. At transmission type 253 the data is updated at the reception of the remote frame. These values are only possible for transmit PDOs.

Transmission type 255 means, the application event is defined in the device profile. For receive PDOs the reception of a PDO will update the mapped data (normally the analog or digital outputs).

Sub-index 3h contains the inhibit time. This time is a minimum interval for PDO transmission. The value is defined as multiple of 100ms.

In mode 254/255 additionally an event time can be used for TPDO. If an event timer exists for a TPDO (value not equal to 0) the elapsed timer is considered to be an event. The event time is a multiple of 1 ms. This event will cause the transmission of this TPDO in addition to otherwise defined events.

The PDO communication parameter objects have the same structure for all PDOs. The following Objects are used.

Sub-index 4h is reserved.

Index	PDO
1400h	Receive PDO1
1401h	Receive PDO2
1402h	Receive PDO3
1403h	Receive PDO4
1800h	Transmit PDO1
1801h	Transmit PDO2
1802h	Transmit PDO3
1803h	Transmit PDO4

Index	14xxh / 18xxh
Name	Receive / Transmit PDOx Communication Parameters
Description	-
Data Type	Structure

Index	14xxh / 18xxh Subindex 0
Name	Largest SubIndex supported
Description	-
Data Type	Unsigned 8
Access modes	RO
PDO Mapping	No
Value Range	-
Default Value	2 / 5

Index	14xxh / 18xxh Subindex 1																
Name	COB-ID																
Description	Identifier for CAN-Object for PDO																
Data Type	Unsigned 32																
Access modes	RW																
PDO Mapping	No																
Value Range	-																
Default Value	<table border="1"> <tr> <td>1400.01</td> <td>Node-Id + 80000200h</td> </tr> <tr> <td>1401.01</td> <td>Node-Id + 300h</td> </tr> <tr> <td>1402.01</td> <td>Node-Id + 80000400h</td> </tr> <tr> <td>1403.01</td> <td>Node-Id + 80000500h</td> </tr> <tr> <td>1800.01</td> <td>Node-Id + 80000180h</td> </tr> <tr> <td>1801.01</td> <td>Node-Id + 280h</td> </tr> <tr> <td>1802.01</td> <td>Node-Id + 380h</td> </tr> <tr> <td>1803.01</td> <td>Node-Id + 80000480h</td> </tr> </table>	1400.01	Node-Id + 80000200h	1401.01	Node-Id + 300h	1402.01	Node-Id + 80000400h	1403.01	Node-Id + 80000500h	1800.01	Node-Id + 80000180h	1801.01	Node-Id + 280h	1802.01	Node-Id + 380h	1803.01	Node-Id + 80000480h
1400.01	Node-Id + 80000200h																
1401.01	Node-Id + 300h																
1402.01	Node-Id + 80000400h																
1403.01	Node-Id + 80000500h																
1800.01	Node-Id + 80000180h																
1801.01	Node-Id + 280h																
1802.01	Node-Id + 380h																
1803.01	Node-Id + 80000480h																

An Identifier of 80000X00h means, that this PDO is disabled by default and must be enabled from the CANopen master by assigning a valid PDO ID.

Index	14xxh / 18xxh Subindex 2
Name	Transmission Type
Description	-
Data Type	Unsigned 8
Access modes	RW
PDO Mapping	No
Value Range	-
Default Value	0FFh

Index	14xxh / 18xxh Subindex 3
Name	Inhibit Time
Description	-
Data Type	Unsigned 16
Access modes	RW
PDO Mapping	No
Value Range	-
Default Value	0

Index	14xxh / 18xxh Subindex 4
Name	Reserved
Description	-
Data Type	-
Access modes	-
PDO Mapping	No
Value Range	-
Default Value	-

Index	14xxh / 18xxh Subindex 5
Name	Event Time
Description	-
Data Type	Unsigned 16
Access modes	RW
PDO Mapping	No
Value Range	-
Default Value	0

PDO Mapping Objects

The following table shows the PDO Mapping Objects. The principle of PDO mapping is the same for all PDOs. The PDO Mapping table is the cross reference between the Object dictionary entries (for example the data of an digital output byte) and the data field inside an PDO data field (position in the data field of a CAN message for PDO transfer).

Subindex 0 determines the valid number of objects that have been mapped. The hipecs-CIO allows a maximum of 8 mapped objects for each PDO. For changing the PDO mapping first subindex 0 must be set to 0 (mapping is deactivated). Then the objects can be remapped. When a new object is mapped by writing a subindex between 1 and 8, the device may check whether the object specified by index /subindex exists. If the object does not exist or the object cannot be mapped, the SDO transfer will be aborted.

Subindexes 1 to 8 keep the pointers of the mapped objects as unsigned 32 values. The value is 0 if there is no mapped object. The structure for these pointers is as follows.

MSB		LSB	
Byte3	Byte2	Byte1	Byte0
Mapped index		Subindex	Length

Mapped Index and Subindex together are the Pointer to the Object dictionary data to be mapped at this location.

Length gives the length of the mapped object in bits.

Index	160xh / 1A0xh
Name	Receive / Transmit PDO Mapping Parameters
Description	-
Data Type	Array

Index	160xh / 1A0xh Subindex 0
Name	Largest SubIndex supported
Description	Number of mapped objects
Data Type	Unsigned 8
Access modes	RW
PDO Mapping	No
Value Range	-
Default Value	See table below

Index	160xh / 1A0xh Subindex 1 to 8
Name	Mapped object
Description	
Data Type	Unsigned 32
Access modes	RW
PDO Mapping	No
Value Range	-
Default Value	See table below

Receive PDOs

The hipecs-CIO150 CANopen IO uses the following default mapping entries for receive PDO mapping:

Index	Entry	Explanation
Receive-PDO1		
1600.00	2	RPDO1: no mapped objects
Receive-PDO2		
1601.00	0	RPDO2: 2 mapped objects
1600.01	62000108h	Digital Output Byte0
1600.02	62000208h	Digital Output Byte1
Receive-PDO3		
1602.00	0	RPDO3: no mapped objects
Receive-PDO4		
1603.00	0	RPDO4: no mapped objects

Transmit PDOs

The hipecs-CIO150 CANopen IO uses the following default mapping entries for receive PDO mapping:

Index	Entry	Explanation
Transmit - PDO1		
1A00.00	2	TPDO1: no mapped objects
Transmit - PDO2		
1A01.00	4	TPDO2: 4 mapped objects
1A01.01	64010110h	Analog Input Integer 0
1A01.02	64010210h	Analog Input Integer 1
1A01.03	64010310h	Analog Input Integer 2
1A01.04	64010410h	Analog Input Integer 3
Transmit - PDO3		
1A02.00	4	TPDO3: 4 mapped objects
1A02.01	64010510h	Analog Input Integer 4
1A02.02	64010610h	Analog Input Integer 5
1A02.03	64010710h	Analog Input Integer 6
1A02.04	64010810h	Analog Input Integer 7
Transmit - PDO4		
1A03.00	0	TPDO4: no mapped objects

Manufacturer Specific Profile Area

The Objects in this area offer special device specific functions in order to configure additional functions implemented in the devices firmware. These additional functions can not be edited within the standardized profile areas.

Index 2000 : Device Manufacturer

This Object shows "Frenzel + Berg" as visible string. If OEMs do not want to give access to this entry, it may be removed from the EDS (electronic data sheet).

Index	2000h
Name	Device Manufacturer
Description	-
Data Type	Visible String
Access modes	RO
PDO Mapping	No
Value Range	The maximum string length is 20 characters
Default Value	"Frenzel + Berg"

Index 2009 : Serial Number 64 Bit

This Object shows the serial number of the device. The serial number is given as an unsigned 64 bit number and is divided into two sub objects.

Index	2009h
Name	Serial Number 64 Bit
Description	-
Data Type	Array

Index	2009h Subindex 0
Name	Largest SubIndex supported
Description	-
Data Type	Unsigned char
Access modes	RO
PDO Mapping	No
Value Range	-
Default Value	2

Index	2009h Subindex 1
Name	Serial Number 64 Bit Low Double Word
Description	Holds bits 0 .. 31 of the serial number
Data Type	Unsigned 32
Access modes	RO
PDO Mapping	No
Value Range	-
Default Value	-

Index	2009h Subindex 1
Name	Serial Number 64 Bit High Double Word
Description	Holds bits 32 .. 63 of the serial number
Data Type	Unsigned 32
Access modes	RO
PDO Mapping	No
Value Range	-
Default Value	-

Index 2101 : System Configuration

This Object returns the operation mode of the hipecs-CIO.

Index	2101h
Name	System Configuration
Description	-
Data Type	Unsigned 32
Access modes	RO
PDO Mapping	No
Value Range	-
Default Value	0

Index 2102 : Remapping Enabled Info

This Object informs the user whether the system configuration enables remapping of the PDOs. A value of 0 means that remapping is disabled, all other values indicate that remapping of the PDOs is enabled.

Index	2102h
Name	Remapping Enabled Info
Description	-
Data Type	Unsigned 8
Access modes	RO
PDO Mapping	No
Value Range	-
Default Value	1

Index 2103 : Enabled Guarding Warning

This Object enables/disables transmission of emergency messages in case of a node guarding warning.

The condition of a guarding warning is met, if the time between two node guarding frames increases the guarding time given in object 100C independent of the setting of the life time (object 100D). The node guarding warning does not cause any NMT state change or switching the output pins to the error state. It is implemented to give the CANopen master an early information that the guarding interval has already exceeded the predefined value.

0 : Guarding Warning is disabled

1 : Guarding Warning is enabled

Index	2103h
Name	Enable Guarding Warning
Description	-
Data Type	Unsigned 8
Access modes	RW
PDO Mapping	No
Value Range	-
Default Value	0

Index 2105 : Internal Error Code

This Object holds error information of the CANopen controller.

Index	2105h
Name	Internal Error Code
Description	-
Data Type	Unsigned 32
Access modes	RO
PDO Mapping	YES
Value Range	-
Default Value	0 (no error condition)

Index 2110 : Test Object

This Object is implemented for testing purposes and should not be used.
The test entry does not have any functional behaviour.

Index	2110h
Name	Test Object 01
Description	-
Data Type	Structure

Index	2110h Subindex 0
Name	Largest SubIndex supported
Description	-
Data Type	Unsigned char
Access modes	RO
PDO Mapping	No
Value Range	-
Default Value	0x01

Index	2110h Subindex 1
Name	Test Object 01
Description	-
Data Type	Unsigned 16
Access modes	RW
PDO Mapping	No
Value Range	100 .. 1000
Default Value	500

Index 2180 : CAN Restart Time

This Object gives the restart time out for the CAN communication layer in case of bus off errors in milliseconds.

If the restart time is set to 0 automatic restart of the device in case of bus off is prohibited.

Index	2180h
Name	CAN Restart Time
Description	-
Data Type	Unsigned 16
Access modes	RW
PDO Mapping	No
Value Range	0 .. 50000
Default Value	1000 (restart after one second)

DS401: Analog Input Objects

The following objects are describing the functionality of the analog input lines of the hipecs-CIO150.

Index 6401 : Read Analog Input 16 Bit

Object 6401, represents the value of the analog channels. The 16 bit conversion result of the analog input voltage is a signed value. The input pins are scanned only for positive voltages, so the valid range for object 6401 is 0x00 to 0x7FFF representing input voltage range from 0 to AVref

The mapping of the I/O lines to object 6401 is explained in chapter "Mapping I/O to Object Dictionary"

Index	6401h
Name	Read Analog Input
Description	-
Data Type	Array

Index	Subindex 0
Name	
Description	Number of mapped objects
Data Type	Unsigned 8
Access modes	RO
PDO Mapping	NO
Value Range	-
Default Value	Number of analog input bytes

Index	Subindex 1 to Nr of input lines
Name	Read Analog Input
Description	
Data Type	Signed 16
Access modes	RO
PDO Mapping	YES
Value Range	-
Default Value	-

Index 6421 : Analog Input Interrupt Trigger

Object 6421 selects the event that shall cause a transmission interrupt for the selected analog channel.

There is one Subindex for each channel to enable individual setting according to application requirements.

Table of possible Trigger Conditions:

Bit Nr	Interrupt Trigger Selection
0	Input voltage greater than Upper Limit
1	Input voltage less than Lower Limit
2	Input changed by more than Delta
3	Input reduced more than Negative Delta
4	Input increased more than Positive Delta
5 to 7	Reserved (must be forced to zero)

Index	6421h
Name	Analog Input Interrupt Trigger
Description	-
Data Type	Array

Index	Subindex 0
Name	
Description	Number of mapped objects
Data Type	Unsigned 8
Access modes	RO
PDO Mapping	NO
Value Range	-
Default Value	Number of analog input lines

Index	Subindex 1 to Nr of input lines
Name	Analog Input Interrupt Trigger
Description	Selects trigger condition
Data Type	Unsigned 8 (See Table of Trigger Conditions)
Access modes	RW
PDO Mapping	No
Value Range	-
Default Value	7

Index 6423 : Analog Input Interrupt Enable

This object enables or disables globally the interrupt behaviour without changing the interrupt masks. The interrupt is disabled by default, in order to avoid transmission of analog input values.

TRUE (1)= global interrupt enabled
FALSE (0)= global interrupt disabled

Index	6423h
Name	Analog Input Interrupt Enable
Description	-
Data Type	Boolean
Access modes	RW
PDO Mapping	No
Value Range	-
Default Value	FALSE

Index 6424/5/6/7/8 : Analog Input Interrupt Limits

These objects give the Limit for generation of interrupts. All objects have the same structure. The function of the interrupt limit is only enabled, if the corresponding bit of object 6421 is set. All values of limit parameters are signed 32. So the user must take care not to exceed the range of the input data objects.

Note especially for limit calculations
For calculation whether an interrupt (PDO transmission) must be generated or not, the analog input data object (6401.xx) is always evaluated as signed value, even if an offset is set to simulate an unsigned value.

Table of Limit Function

Object	Object Name and Function
6424	Analog Input Upper Limit Generate interrupt if input voltage is greater than or equal to Upper Limit (6424)
6425	Analog Input Lower Limit Generate interrupt if input voltage is less than Lower Limit (6425)
6426	Analog Input Interrupt Delta Generate interrupt if input voltage changed by more than Interrupt Delta
6427	Analog Input Negative Delta Generate interrupt if input voltage reduced by more than Negative Delta
6428	Analog Input Positive Delta Generate interrupt if input voltage increased by more than Positive Delta

Index	6424/5/6/7/8/9
Name	See table above
Description	-
Data Type	Array

Index	Subindex 0
Name	
Description	Number of mapped objects
Data Type	Unsigned 8
Access modes	RO
PDO Mapping	NO
Value Range	-
Default Value	Number of analog input lines

Index	Subindex 1 to Nr of input lines (8)
Name	See table above
Description	
Data Type	Integer 32
Access modes	RW
PDO Mapping	No
Value Range	-
Default Value	0

DS401: Analog Output Objects

The following objects are describing the functionality of the analog output channels of the hipecs-CIO150. The CIO150 module supports 16 bit access to the analog outputs.

The mapping of the outputs to object 6411 is explained in chapter "Mapping I/O to Object Dictionary"

Index 6411 : Write Analog Output

With object 6411, the analog outputs of the CIO150 can be written. The output resolution is 12 bit.

Value Range:

Volt:	Value in Object 6411h:
-10	55.535 (D8Ef h)
0	0
10	10.000 (2710 h)

The mapping of the I/O lines to object 6411 is explained in chapter "Mapping I/O to Object Dictionary"

Index	6411h
Name	Write to digital output
Description	-
Data Type	Array

Index	Subindex 0
Name	
Description	Number of mapped objects
Data Type	Unsigned 8
Access modes	RO
PDO Mapping	NO
Value Range	-
Default Value	Number of digital output bytes

Index	Subindex 1 to Nr of outputs
Name	Write to analog output
Description	
Data Type	Integer 16
Access modes	RW
PDO Mapping	YES
Value Range	0 .. 0x7FFF
Default Value	0

Index 6443 : Error Mode Output 16 Bit

This object indicates, whether an output is forced to a predefined value (given in object 6444) in case of a device error.

1 = Output will be forced to the value selected in object 6444

0 = Output will be unchanged even in case of an error condition.

Index	6443h
Name	Error Mode Output 16 Bit
Description	-
Data Type	Array

Index	Subindex 0
Name	Nr of Subobjects
Description	
Data Type	Unsigned 8
Access modes	RO
PDO Mapping	No
Value Range	-
Default Value	4 h

Index	Subindex 1 to Nr of outputs
Name	Error Mode Output 8 Bit n
Description	
Data Type	Unsigned 8
Access modes	RW
PDO Mapping	No
Value Range	-
Default Value	0001h (Take error condition from object 6444)

Index 6444 : Error Value Output 32 Bit

This object selects the level the outputs are forced to in case of device error mode if the error mode (object 6443 is enabled)

1 = Output will be forced to active state

0 = Output will be forced to inactive state.

Index	6443h
Name	Error Value Output 32 Bit
Description	-
Data Type	Array

Index	Subindex 0
Name	Nr of Subobjects
Description	
Data Type	Unsigned 8
Access modes	RO
PDO Mapping	No
Value Range	-
Default Value	4 h

Index	Subindex 1 to Nr of outputs
Name	Error Value Output 32 Bit n
Description	
Data Type	Integer 32
Access modes	RW
PDO Mapping	No
Value Range	-
Default Value	0 (Inactive, high level)

Emergency Messages

Das hipecs-CIO150 Modul unterstützt diverse Emergency Messages. Für alle Emergencys wird die selbe Struktur angewendet.

Byte								
0	1	2	3	4	5	6	7	
EMY-Code	1001	0	CIO150-Code					

EMY-Code: Emergency-Error-Code nach DS301

1001: Inhalt von Object 1001

CIO150-Code: Emergency-Error-Code CIO150 als unsigned 32 Wert

CIO-XXX-Code (hex)	ändert:		Beschreibung
	NMT	I/O	
8000 0000	X	X	CAN bus ist bus off
4000 0000			CAN bus in error warning state
2000 0000			Node guarding Warnung
3000 0000	X	X	Life guarding error
0000 0001	X	X	Überlast am Ausgang
0000 0100			Wake up vom Power down Modus

Die Emergency 2000 0000 (Node guarding Warnung) muss über das Objekt 2103 freigeschalten werden.

Wenn mehr als eine Fehlermeldung zur selben Zeit aktiv sind, wird das CIO150-Code Bitmuster durch eine logische Verknüpfung der einzelnen Codes gebildet.

Manche der Emergencys können einen NMT-State-Wechsel bewirken oder die Ausgänge in den Fehlerzustand setzen. Das jeweiligen Verhalten hängt von den Einstellungen im Objekt 1029 ab.

Der Identifier für die Emergency-Nachrichten ist festgelegt auf: **0x80 + Knotennummer**

Liste der Emergency-Nachrichten:

Node-Guarding Warnung							
30	81	01	00	00	00	00	20

Diese Nachricht wird vom Knoten gesendet, wenn der Master nicht innerhalb der spezifizierten „guard time“ (Objekt 100C) einen „guarding remote frame“ endet. Diese Funktion wird im Objekt 2103 eingestellt.

Life-Guarding Fehler

30	81	11	00	00	00	00	30
----	----	----	----	----	----	----	----

Dieser Fehler tritt auf, wenn der Master nicht innerhalb der eingestellten „Life Time“ einen „guarding remote frame“. (Guard Time im Objekt 100C multipliziert mit dem Lifetime-Faktor Objekt 100D)

CAN Bus im Error Warning state

00	81	01	00	00	00	00	40
----	----	----	----	----	----	----	----

Fehlermeldung wenn sich das chipinterne CAN-Modul im „error warning state“ befindet.

Rückkehr aus CAN-Bus-Off

40	81	01	00	00	00	00	C0
----	----	----	----	----	----	----	----

Mit dieser Nachricht zeigt der Knoten seine Rückkehr vom Bus-Off-Zustand an.

Daten-Mapping im Objektverzeichnis

Betriebsmodus 0								
8 analoge Eingänge / 4 analoge. Ausgänge								
EDS-file: hipecs_CIO150.EDS								
Mapping im Objektverzeichnis								
Index.	gemapptes I/O Signal Bit/Wert							
SubIndex	7	6	5	4	3	2	1	0
6401.01	AIN0							
6401.02	AIN1							
6401.03	AIN2							
6401.04	AIN3							
6401.05	AIN4							
6401.06	AIN5							
6401.07	AIN6							
6401.08	AIN7							
6411.01	AOUT0							
6411.02	AOUT1							
6411.03	AOUT2							
6411.04	AOUT3							
Default PDO Mapping								
PDO	gemappte Daten							
RPDO1	6411.01 analog Ausg. AOUT0 6411.02 analog Ausg. AOUT1 6411.03 analog Ausg. AOUT2 6411.04 analog Ausg. AOUT3							
TPDO1	6401.01 analog Eing. AIN0 6401.02 analog Eing. AIN1 6401.03 analog Eing. AIN2 6401.04 analog Eing. AIN3							
TPDO2	6401.05 analog Eing. AIN4 6401.06 analog Eing. AIN5 6401.07 analog Eing. AIN6 6401.08 analog Eing. AIN7							

Version History

Version	Datum	Änderung
1.13 Rev. 01	30.09.2011	Erste Version
1.49 Rev. 01	16.09.2013	Beschreibung der CANopen-Objekte eingefügt
1.49 Rev. 02	18.09.2013	Temperaturbereich von 0 .. 70°C auf 0 .. 55°C geändert
1.49 Rev. 03	27.01.2014	Korrektur max. Kapazität am Ausgang von 4 µF auf 4 nF Darstellung der CAN Signal LEDs geändert
1.49 Rev. 04	29.04.2014	Korrektur Datenblatt
1.49 Rev. 05	21.08.2014	Abbildungen korrigiert
1.49 Rev. 06	21.10.2014	Aktualisierung Temperaturbereiche

Inhaltsverzeichnis

Allgemein	1
Funktionen	1
Bestellinformation	1
Technische Daten	2
Steckerbelegung X1 (CAN)	3
Steckerbelegung X2 (analoge Eingänge)	3
Steckerbelegung X3 (PCPU Versorgung)	3
Steckerbelegung X4 (Analog Output Byte)	3
Lageplan Fehler! Textmarke nicht definiert.	
Konfiguration Dip-Schalter	4
DIP1 und DIP2 am Einstellmodul.....	4
SW3 auf dem Board	4
CAN Signal LED's	5
Prinzipschaltbild analoge Eingänge	6
Prinzipschaltbild analoge Ausgänge	6
Abmessungen Kunststoffgehäuse	7
CANopen Objektverzeichnis	8
Bemerkung: DS301 PDO Parameter Objekte.....	13
Description of Object Dictionary	14
Index 0005.....	14
Index 0006.....	14
Index 0007.....	14
DS301: Global Objects	14
Index 1000 : Device Type	14
Index 1001 : Error Register.....	14
Index 1002 : Status Register	15
Index 1005 : COB-ID Sync	15
Index 1008 : Device Name	15
Index 1009 : Hardware Version	15
Index 100A : Software Version	15
Index 100C : Guard Time	15
Index 100D : Life Time Factor	16
Index 100E : COB-ID Guard	16
Index 1014 : COB-ID Emergency	16
Index 1015 : Inhibit Time Emergency	16
Index 1016 : Consumer Heartbeat Time.....	16
Index 1017 : Producer Heartbeat Time.....	17
Index 1018 : Identity Object.....	17
Index 1029 : Error Behaviour.....	18
DS301: PDO Parameter Objects	19
Communication Parameter Objects.....	19
PDO Mapping Objects.....	20
Manufacturer Specific Profile Area	21
Index 2000 : Device Manufacturer.....	21

Index 2009 : Serial Number 64 Bit.....	21
Index 2101 : System Configuration.....	22
Index 2102 : Remapping Enabled Info	22
Index 2103 : Enabled Guarding Warning.....	22
Index 2105 : Internal Error Code	22
Index 2110 : Test Object	23
Index 2180 : CAN Restart Time.....	23

DS401: Analog Input Objects

Index 6401 : Read Analog Input 16 Bit.....	23
Index 6421 : Analog Input Interrupt Trigger.....	24
Index 6423 : Analog Input Interrupt Enable	24
Index 6424/5/6/7/8 : Analog Input Interrupt Limits .24	

DS401: Analog Output Objects

Index 6411 : Write Analog Output.....	25
Index 6443 : Error Mode Output 16 Bit	26
Index 6444 : Error Value Output 32 Bit.....	26

Emergency Messages

Daten-Mapping im Objektverzeichnis.....

Version History

Inhaltsverzeichnis