

General Description

The hipecs-PLC1000 is high performance and small size PLC. It covers the powerful CoDeSys PLC runtime system, a CANopen master and the Serial Graphic Interface (SGI) as an interface to visualization panels in one device.

PLC

The implemented PLC runtime system is programmable with the (3S) CoDeSys Software. It is one of the most powerful IEC 61131-3 programming tools for controllers' applications for Windows. All five languages of this standard are supported, plus a graphic editor for freehand FBD (function block diagram). CoDeSys produces native machine code for the hipecs-PLC1000 based CPU.

CANopen

The hipecs-PLC1000 supports two CANopen interfaces, that work independent from each other. Both interfaces support either CANopen master or slave functionality. The opto isolated onboard CAN transceivers allows direct connection to a CAN bus line according to ISO11898.

Visualization

One of the serial channels can be configured as Serial Graphic Interface (SGI) in order to connect a visualization panel of the VISU-Pxxx series. With this panels a peripheral operator interface, that is also programmed with the CoDeSys development environment, can be added to the system.

Communication

Three asynchronous serial interfaces (2x RS232 and 1x RS422/485) provides communications with several external devices, PCs, scanners, machines etc.

The communication from the hipecs-PLC1000 to the CoDeSys programming tools, running on a PC, will be done with the USB interface. This allows online debugging and in circuit programming. An additional USB channel allows direct access to the file system shell via PC.

File System

The file system supports the on board flash drive as well as an external micro SD-Card. For this a micro SD-Card slot is built-in front side. Maximum file size for a single file is 2 GB.

Ethernet

The Ethernet interface allows to integrate the hipecs system into networks. This interface supports the SMTP, FTP and HTTP protocol so a CoDeSys login and visualization via internet is possible.

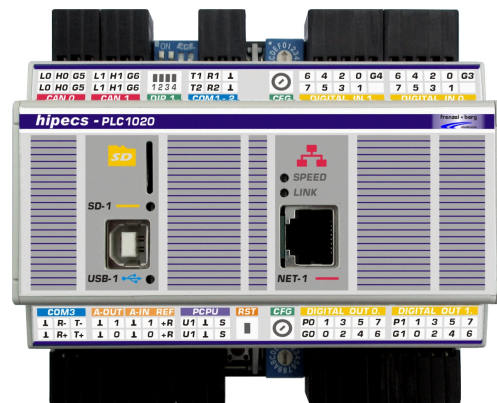

Ordering Information

Article number	name	Description
EZ00000.1810.00	PLC1010i	16/16 digital I/O, 2/2 analog I/O, 3x serial interface, 2x CAN-bus, 1x USB interface, 1x SD-card reader
EZ00000.1820.00	PLC1020i	like PLC1010 additional: 1x Ethernet interface,
EZ00000.1830.00	PLC1030i	like PLC1010 additional: 1x Ethernet interface, 2nd USB interface
EZ00000.1910.01	PLC1210i	like PLC10XX
EZ00000.1920.01	PLC1220i	additional:
EZ00000.1930.01	PLC1230i	6x PT100/PT1000

I/O and special features

16 digital inputs, 16 digital outputs, 2 analog inputs and 2 analog outputs with several special functions are realized on device.

There are several additional features provided with the I/O pins:

Three pairs of input pins may be used for direct connection of encoders with tracks A and B. One additional channel provides a hardware counting feature with direction control. The encoder channels may also be configured as event counter input pins. Interrupt functionality is configurable on up to 6 input pins.

Ten of the 16 digital outputs provides PWM or frequency generation on 4 independent configurable time bases.

The PLC12XX Versions offer inputs for PT100 or PT1000 temperature measuring.

Further Memory options

The integrated battery buffered real-time clock provides current date and time. A non volatile memory offers space for retain variables.

Features

The following Chapters describe the main features of the hipecs-PLC1000 device. Additional features and libraries are available on request.

PLC features

- High speed 16 bit CPU kernel
2000 IEC commands per millisecond
- IEC 61131-3 programmable
with CoDeSys development environment
- Powerful preemptive multi tasking operating system. 8 CoDeSys application tasks.
- Memory
512 kByte PLC application data memory
4 kByte PLC application retain data
2 kByte EEPROM memory
1 kByte NV memory
256 Mbyte PLC code memory and
internal files system
up to 4 GByte external SD-Card (optional)
- Real Time Clock
- 16 digital input lines 24V level (12V on request)
- 16 digital output lines 24V level (12V on request)
- 2 analog input lines (0..10V)
10 bit resolution
- 2 analog output lines (0..10V)
10 bit resolution

CANopen features

- The hipecs-PLC1000 supports two completely independent CANopen interfaces that can be configured to work as a CANopen master or slave.
- CANopen master according to
DS301 Version 4
DSP302 Version 3.0
DSP405 Version 2.0
- Up to 32 CANopen slaves supported
- Slave configuration with EDS files directly with CoDeSys PLC programming tool.
- CANopen slave according to
DS401 Version 2.1
- Up to 250 Transmit PDOs (master mode)
Up to 16 Transmit PDOs (slave mode)
- Up to 250 Receive PDOs (master mode)
Up to 16 Receive PDOs (slave mode)
- Dynamic PDO mapping
- Variable PDO Identifier
- Node guarding, Life guarding, Heartbeat
- Sync
- Emergency reporting for PLC application
- Client SDO transfer for PLC application
- Baud rate up to 1 MBaud
- CAN bus ISO11898 transceiver 82C251

VISU features

- Powerful CoDeSys target visualization with peripheral VISU-Pxxx series of operator panels.
- In system Serial Graphic Interface (SGI) Driver
- External Graphic Controller reduces system load caused by visualization to a minimum.
- Support of multiple predefined graphic objects like lines, rectangles, buttons, bitmaps etc.
- Several fonts and text sizes.
- Support of Unicode16 characters.
- Support for different languages using the CoDeSys .xml file based language switching.
- Connection to operator panel with any serial interface possible.
- Baud rate up to 460800 Baud

PT100/PT1000 Temperature Measurement

- PT100 or PT1000 measurement
- up to 6 channels for 2-wire-measurement
- up to 3 channels for 3-wire-measurement
- up to 2 channels for 4-wire-measurement
- additional module connected to internal onboard CANopen

Interrupt features

- Interrupt processing for IEC61131 tasks
- 6 separated interrupt input lines
- Programmable edge sensitivity for all interrupt channels: rising, falling or both edges
- Programmable priority level for each channel

Encoder Interface

- Integrated incremental encoder interface with 3 channels
- Direct connection of 2 track encoder types
- 32 Bit count values
- Built in library for complete encoder control

Event Counter

- Integrated event counters with 5 channels
- Event counter mode optional
- 32 Bit count values
- Built in library for complete counter control

Serial Interfaces

- 2 serial RS232 interfaces programmable baud rates up to 460800.
- 1 serial RS422/485 interface programmable baud rates up to 460800.
- Each of the interface can be used as an SGI interface port to a visualization panel

USB

- 1 USB channel programming interface for connection to the CoDeSys development environment
- 1 USB channel for direct access to the file system shell via PC
- 2 USB channels (*to be defined*)

Ethernet

- Simple mail transfer protocol SMTP
- File transfer protocol FTP
- Hypertext transfer protocol HTTP

Additional features

- Temperature range 0°-70° (other on request)
- Dimension unplugged (108 x 100 x 60) mm
- DIN-Rail mounting

SD-Card slot

- Card slot for preformatted micro SD-Cards FAT16, FAT32
- Supports micro SD-Cards up to 4 GB

Customer features

Additional library features with special functions or OEM versions with own CoDeSys target file are available on request.
Do not hesitate to contact us.

Technical Data

The hipecs-PLC1000 has separated power supplies for the CPU / logic and the digital I/O groups. Opto-isolated groups may also have separate ground for each circuit.

Power Supply	Min.	Norm.	Max.
Logic (CPU) supply voltage DC	10 V	24 V	30 V
Current consumption logic (CPU)			
Digital I/O supply voltage (each I/O group) Upd	10 V	24 V	30 V
Current consumption dig. I/O (each I/O group)	(80mA max.) + (summary of driven load)		
Inverse-polarity protection (all supply inputs)	Yes		

Digital Inputs	(own ground for each group!)
Number of inputs	16 (2 groups of 8 inputs)
Switching	positive
Indication	LED
Input voltage range (limits)	0 .. 30 V
Input impedance	> 3,3 k Ω
Signal Level LOW	0 .. 3 V
Signal Level High	>14 V
Input frequency	0 .. 100 kHz
Inverse-polarity protection	Yes

Digital Outputs (Type A) (Group 0)	(own ground for group!)
Number of outputs	8
Switching	positive
Short circuit protected	Yes
Over current protected	Yes
Output current continuously	100 mA
Output current peak	350 mA (< 5 s)
Output shut down current	~ > 370 mA
Output voltage HIGH	Upd – 1 V
Output voltage LOW	(high impedance)
Output load ability	resistive, inductive, lamps
Output frequency	0 .. 60 kHz
Galvanic isolation (I/O to system)	500 V rms (for 1 minute)

Digital Outputs (Type B) (Group 1)	(own ground for group!)
Number of outputs	8
Switching	positive
Short circuit protected	Yes
Over current protected	Yes
Output resistance (RDson)	< 0,25 Ω
Output current continuously	500 mA
Output current peak	1,5 A (< 1 s)
Output shut down current	~ > 520 mA
Output voltage HIGH	Upd – 1 V
Output voltage LOW	(high impedance)
Output load ability	resistive, inductive, lamps
Output frequency	0 .. 1 kHz
Galvanic isolation (I/O to system)	500 V rms (for 1 minute)

Analog Inputs	
Number of inputs	2
measurement	voltage
Measurement range	0 .. 10,5 V
Input voltage range (limits)	0 .. 30 V
Input resistance	> 180 k Ω
Input capacitance	~ 10 nF
ADU resolution	10 bit
Accuracy	~ 3 %
Input frequency	0 .. 1 kHz
Inverse-polarity protection	Yes
Galvanic isolation (Input to system)	No

Analog Outputs	
Number of outputs	2
Short circuit protected	Yes
Output voltage range	0 .. 10 V
Output current max.	5 mA
resolution	10 bit
Accuracy	~ 3 % of full scale
Output frequency	0 .. 250 Hz
Galvanic isolation (Input to system)	No

PT100 / PT1000 input for hipecsPLC12XX	
number of channels	4 or 6 (2-wire-measurement)
	3 (3-wire-measurement)
	2 (4-wire-measurement)
measurement current	0,5 mA .. 1 mA (PT100)
	0,05 mA .. 0,1 mA (PT1000)
resolution (ADU)	16 Bit
measuring range	-100 $^{\circ}$ C .. +500 $^{\circ}$ C
resolution (measuring range)	0,1K
temperature drift 2 and 4 wire measurement	20 ppm/K
temperature drift 3 wire measurement	30 ppm/K
max. measurement error	+/- (0,4 K + 0,4% of measured value)

Reference Voltage Outputs	
Number of outputs	1
Short circuit protected	Yes
Output voltage	10 V DC (fix)
Output current max.	5 mA
Accuracy	~ 3 %
Galvanic isolation (Input to system)	No

CAN Bus	(own channel ground)
Number of channels	2
Short circuit protected	Yes
Galvanic isolation (bus to system)	Yes
CAN-Bus Norm	ISO11898
CAN-Transceiver	PCA82C251T (or compatible)
CiA Draft Standards	DS301 Version 4.0 und DS401 Version 2.0
Bus termination (switchable)	Not connected / 120 Ω

RS232 Interface COM1/COM2	
Number of channels	2
Galvanic isolation (Input to system)	No

SGL Interface / COM3 (RS422/485)	
Number of channels	1
Output termination (transmitter)	120 Ohm
Input termination (receiver)	120 Ohm
Galvanic isolation (Input to system)	No

USB Interface	
Number of channels	1 (PLC1020) / 2 (PLC1030)
Galvanic isolation (Input to system)	No

Ethernet Interface	OPTIONAL
Number of channels	1
Galvanic isolation (Input to system)	Yes

SD-Card Slots	
Number of external slots	2
Number of internal drives	1 (can not be removed by user)
Galvanic isolation (Input to system)	No

Miscellaneous	L x W x H
Dimension (disconnected)	108 x 100 x 62 mm
Dimension (horizontal I/O connectors included)	108 x 124 x 62 mm
Mounting	DIN rail
Temperature range	0 .. 50 °C

Connectors

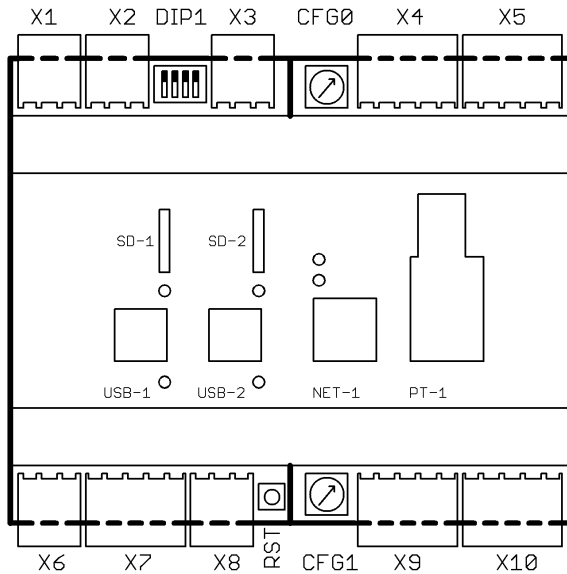

Connectors top view

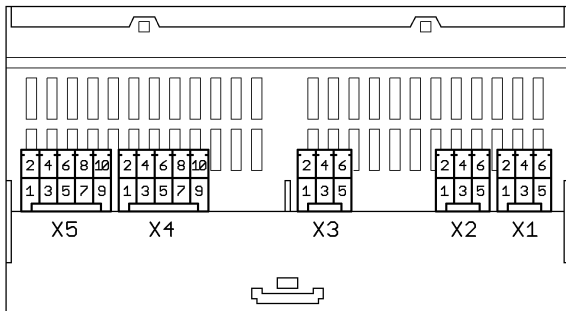

connectors X5 – X1

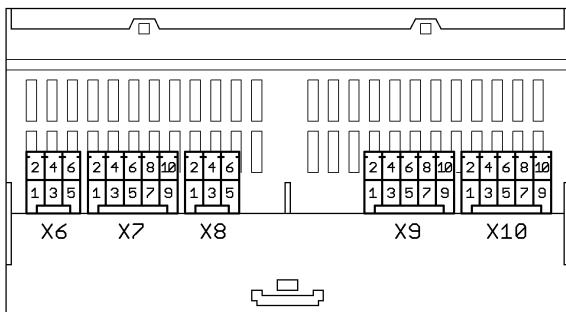

Connectors X6 – X10

X1 CAN0

Type (PCB): WAGO 713-1423
Type (Plug): WAGO 713-1103

Pin	Name	Function
1, 2	CAN0GND	CAN Ground (CAN bus 0)
3, 4	CAN0H	Signal CAN High (CAN bus 0)
5, 6	CAN0L	Signal CAN Low (CAN bus 0)

X2 CAN1

Type (PCB): WAGO 713-1423
Type (Plug): WAGO 713-1103

Pin	Name	Function
1, 2	CAN1GND	CAN Ground (CAN bus 1)
3, 4	CAN1H	Signal CAN High (CAN bus 1)
5, 6	CAN1L	Signal CAN Low (CAN bus 1)

X3 COM1-2

Type (PCB): WAGO 713-1423
Type (Plug): WAGO 713-1103

Pin	Name	Function
1, 2	GND	Common Ground
3	COM1RX	Receiver Input signal (COM1)
4	COM2RX	Receiver Input signal (COM2)
5	COM1TX	Transmitter Output signal (COM1)
6	COM2TX	Transmitter Output signal (COM2)

X4 Digital Input Group 1

Type (PCB): WAGO 713-1425
Type (Plug): WAGO 713-1105

Pin	Name	Function
1	DI1GND	Common group ground signal (input group 1)
2		Not connected
3..10	DIN 1.0 to DIN 1.7	Digital inputs of group 1 input channel 1.0 to 1.7

X5 Digital Input Group 0

Type (PCB): WAGO 713-1425 Type (Plug): WAGO 713-1105		
Pin	Name	Function
1	DIOGND	Common group ground signal (input group 0)
2		<i>Not connected</i>
3..10	DIN 0.0 to DIN 0.7	Digital inputs of group 0 input channel 0.0 to 0.7

X6 COM3 / SGI (RS422/485)

Type (PCB): WAGO 713-1423 Type (Plug): WAGO 713-1103		
Pin	Name	Function
1, 2	GND	Common Ground
3	A (R+)	Receiver Input signal
4	B (R-)	Receiver Input signal inverse
5	Y (T+)	Transmitter Output signal
6	Z (T-)	Transmitter Output signal inverse

X7 Analog In-/Output

Type (PCB): WAGO 713-1425 Type (Plug): WAGO 713-1105		
Pin	Name	Function
1, 2	GND	Common ground
3	AOUT0	Analog output channel 0
4	AOUT1	Analog output channel 1
5, 6	GND	Common ground
7	AIN0	Analog input channel 0
8	AIN1	Analog input channel 1
9, 10	OREF10	Reference voltage output +10V

X8 Main Power Supply (logic/CPU)

Type (PCB): WAGO 713-1423 Type (Plug): WAGO 713-1103		
Pin	Name	Function
1,2	U24L	Power supply input (24V DC) for logic and CPU
3, 4	GND	Common Ground
5, 6	SLD	Shield

X9 Digital Output Group 0

Type (PCB): WAGO 713-1425 Type (Plug): WAGO 713-1105		
Pin	Name	Function
1	DO0GND	Common group ground signal (output group 0)
2	U24DO0	Common group supply voltage (output group 0)
3..10	DOUT 0.0 to DOUT 0.7	Digital outputs of group 0 input channel 0.0 to 0.7

X10 Digital Output Group 1

Type (PCB): WAGO 713-1425 Type (Plug): WAGO 713-1105		
Pin	Name	Function
1	DO1GND	Common group ground signal (output group 1)
2	U24DO1	Common group supply voltage (output group 1)
3..10	DOUT 1.0 to DOUT 1.7	Digital outputs of group 1 input channel 1.0 to 1.7

USB-1 USB-Interface

Type: B		
Pin	Name	Function
1	-	Not connected
2	D -	USB signal D -
3	D+	USB signal D+
4	GND	Common Ground

NET-1 Ethernet-Interface

Type: RJ45		
Pin	Name	Function
1	TX+	Ethernet signal TX+
2	TX -	Ethernet signal TX -
3	RX+	Ethernet signal RX+
4, 5		
6	RX -	Ethernet signal RX -
7, 8		
S	SLD	Shield

PT-1 (PT100/PT1000 connectors)

Pin Nr.	Name	Funktion
1	PTA	PT input A
2	PTB	PT input B
3	PTY	PT input Y
4	PTY	PT input Y
5	PTC	PT input C
6	PTD	PT input D
7	PTY	PT input Y
8	PTY	PT input Y
9	PTE	PT input E
10	PTF	PT input F

Please check chapter "Temperature Measurement" for connection diagram.

LED's

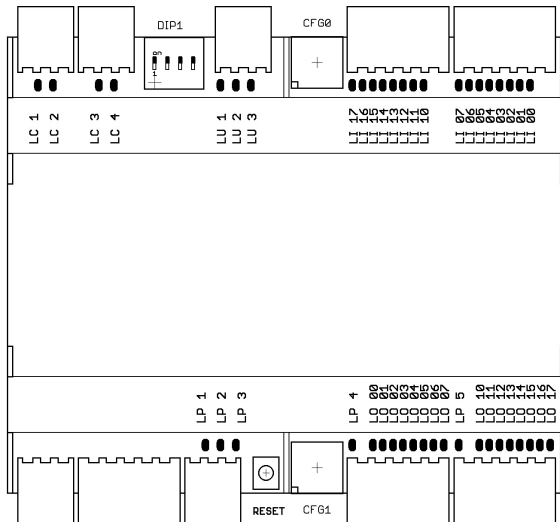

LED's			
Name	Color	Function	
LP 1	green	Power supply indicator 3.3V int.	
LP 2	green	Power supply indicator 5V internal	
LP 3	green	Power supply indicator 24V Logic / CPU supply	
LP 4	green	Power supply indicator 24V Group 0 output supply	
LP 5	green	Power supply indicator 24V Group 1 output supply	
LI 00 ... LI 07	green	Digital input indicator group 0 inputs	
LI 10 ... LI 17	green	Digital input indicator group 1 inputs	
LO 00 ... LO 07	green	Digital output indicator group 0 outputs	
LO 10 ... LO 17	green	Digital output indicator group 1 outputs	
LC 1	green	LED CANopen run (CAN bus 0)	
LC 2	red	LED CANopen error (CAN bus 0)	
LC 3	green	LED CANopen run (CAN bus 1)	
LC 4	red	LED CANopen error (CAN bus 1)	
LU 1	red	User LED 1	User defined / for application specific function.
LU 2	yellow	User LED 2	
LU 3	green	Run LED	Run LED of PLC system

LED CANopen-ERROR

This LED shows the state of the „CAN Physical Layers“ and CAN-Message errors.

Nr.	ERR-LED	State
1	off	No error
2	blinking	Warning limit reached
3	2x flashing	NMT-Error
4	3x flashing	Sync-Error
5	on	BUS-OFF

LED CANopen-RUN

Nr.	RUN-LED	Status
1	off	STOPPED
2	blinking	PRE-OPERATIONAL
3	on	OPERATIONAL

LED-States

LED-States	
LED on	Continuously on
LED off	Continuously off
LED blinking	Blinking with the same on/off time ~ 200ms on, ~ 200ms off (~2,5 Hz)
LED flickering	Flickering with same on/off time ~ 50ms on, ~ 50ms off (~10 Hz)
LED flashing	Blinking with different on/off time ~ 200ms on, and ~ 1s pause

DIP-Switch and CFG-Switches

CFG0:

reserved for future use

CFG1:

Position	Function
0	normal boot-up from internal SD-Card
1	normal boot-up from external SD card (SD1 only)
E	only boot firmware loader from internal SD
F	only boot firmware loader from external SD

DIP1:

Nr.	Function
1	120 ohm termination for CAN0
2	120 ohm termination for CAN1
3	reserved
4	firmware update mode

Digital Inputs

The hipecs PLC1000 provides 16 digital inputs split into 2 different opto isolated groups. So each input group needs explicit (GND) supply connection. The inputs are optimized for 24 Volt applications. A 12 Volt version is available on request.

Group 0 (opto isolated group)	
Number of inputs	8
Connector	X5
Digital inputs	DIN0.0 – DIN0.7
Input type	High speed (.. 100kHz)
<i>See technical data for details</i>	

Group 1 (opto isolated group)	
Number of inputs	8
Connector	X4
Digital outputs	DIN0.0 – DIN0.7
Output type	High speed (.. 100kHz)
<i>See technical data for details</i>	

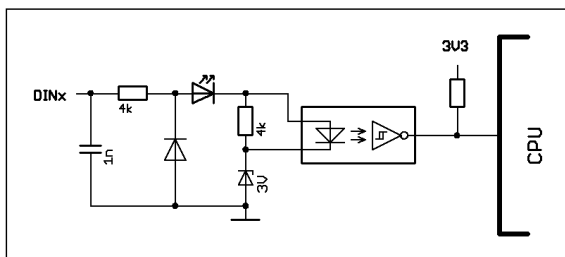

So the inputs are usable as standard digital inputs (in default) or as special function inputs by using an according driver library for initialization.

According CoDeSys Device Driver Libraries	
Digital Input	<i>default</i>
Encoder	FbeSysEncoder.lib
Interrupt	FbeSysInterrupt.lib
-	-
-	-

Using Standard Digital Inputs

This is default mode of all digital inputs. Positive switching logic is defined.

Uin	logic level		
< 3V	LOW	0	False
> 14 V	HIGH	1	True

Using Encoder Inputs

Three independent channels for track A/B encoders are available with the hipecs PLC1000. Each channel uses 2 digital inputs. So if a channel is used as encoder, always both according inputs (A and B) are switched to this special function. Channel 3 is an event counter with direction control.

Using Interrupt Inputs

Six independent interrupt channels for event triggered software functions are available.

Digital Input Reference Overview

Input Reference		Alternative use with special function library		
Input-Name	CoDe Sys-Bit	Encoder-Channel / Track	Interrupt-Channel	
DIN0.0	%IX0.0	0 / A	-	
DIN0.1	%IX0.1	0 / B	-	
DIN0.2	%IX0.2	1 / A	-	
DIN0.3	%IX0.3	1 / B	-	
DIN0.4	%IX0.4	2 / A	-	
DIN0.5	%IX0.5	2 / B	-	
DIN0.6	%IX0.6	3 / IN	-	
DIN0.7	%IX0.7	3 / DIR	-	
DIN1.0	%IX0.8	-	reserved	
DIN1.1	%IX0.9	-	reserved	
DIN1.2	%IX0.10	-	2	
DIN1.3	%IX0.11	-	3	
DIN1.4	%IX0.12	-	4	
DIN1.5	%IX0.13	-	5	
DIN1.6	%IX0.14	-	6	
DIN1.7	%IX0.15	-	7	

Note: If alternative input function is used on an input pin, the value of the normal input bit is not defined. Also make sure, that only one alternative function runs at same input pin. Otherwise malfunction may occur.

Digital Outputs

The hipecs PLC1000 provides 16 digital outputs split into 2 different opto isolated groups. So each output group uses explicit (24V/GND) supply connection.

Group 0	(opto isolated group)
Number of outputs	8
Connector	X9
Digital outputs	DOUT0.0 – DOUT0.7
Output type	High speed (.. 60kHz)
max. current	100 mA
<i>See technical data for details</i>	

Group 1	(opto isolated group)
Number of outputs	8
Connector	X10
Digital outputs	DOUT1.0 – DOUT1.7
Output type	normal (.. 1kHz)
max. current	500 mA
<i>See technical data for details</i>	

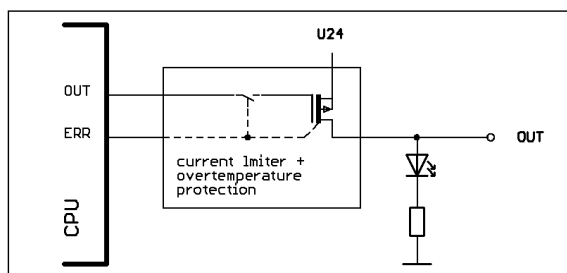

So the outputs are usable as standard digital outputs in default or as a special function outputs by using an according driver library for initialization.

According CoDeSys Device Driver Libraries

Digital Output	<i>default</i>
Pulse Wide Modulation	FbeSysPWM.lib
Stepper Motor	FbeSysSmPos.lib

Using Standard Digital Outputs

This is default mode of all digital outputs. Positive switching logic is defined.

Uout	logic level		
high impedance	LOW	0	False
~ supply voltage	HIGH	1	True

Using PWM Outputs

Up to 6 independent PWM channels for high speed PWM up to 60 kHz are possible to use on output group 0. Two additional channels depending on the same base frequency of channel 5 can also be used for PWM on group 0.

Three channels more for low frequency PWM up to 1 kHz and same base frequency can be used on output group 1.

Using Stepper Motor Outputs

Up to 4 independent stepper motor channels with clock and direction signals are available on output group 0.

Digital Output Reference Overview

Input Reference		Alternative use with special function library		
Input-Name	CoDe Sys	PWM-Channel	Stepper-Channel	
DOUT0.0	%QX0.0	0	0	CLK
DOUT0.1	%QX0.1	1	1	CLK
DOUT0.2	%QX0.2	2	2	CLK
DOUT0.3	%QX0.3	3	3	CLK
DOUT0.4	%QX0.4	4	1	DIR
DOUT0.5	%QX0.5	5 (a)	2	DIR
DOUT0.6	%QX0.6	6 (a)	3	DIR
DOUT0.7	%QX0.7	7 (a)	4	DIR
DOUT1.0	%QX0.8	8 (b)	-	-
DOUT1.1	%QX0.9	9 (b)	-	-
DOUT1.2	%QX0.10	10 (b)	-	-
DOUT1.3	%QX0.11	-	-	-
DOUT1.4	%QX0.12	-	-	-
DOUT1.5	%QX0.13	-	-	-
DOUT1.6	%QX0.14	-	-	-
DOUT1.7	%QX0.15	-	-	-

(a,b) channels uses same base frequency
 CLK Stepper motor clock output
 DIR Stepper motor direction output

Note: If alternative output function is used on an output pin, the value of the normal output bit has no effect. Also make sure, that only one alternative function runs at same output pin. Otherwise malfunction may occur.

Analog Inputs and Outputs

The hipecs PLC1000 provides 2 analog inputs for measurements from 0V to +10V with an resolution of 10 Bits. Two analog outputs with a range of 0V to +10V and a fixed +10V reference voltage output are also available for external use.

Both, the analog outputs and the fixed reference voltage output are short circuit protected.

Analog I/O-Group	
Number of outputs	2
Number of inputs	2
Connector	X7
Analog inputs	AIN0, AIN1
Analog outputs	AOUT0, AOUT1
<i>See technical data for details</i>	

Analog Inputs

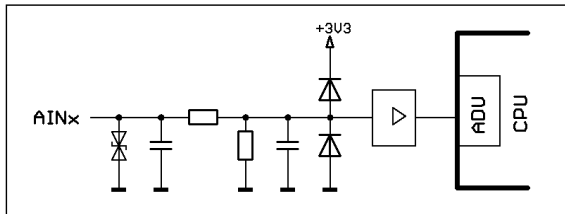

Analog Input Reference		
Input-Name	CoDeSys	
AIN0	Analn0	%IW1
AIN1	Analn1	%IW2

Analog Output

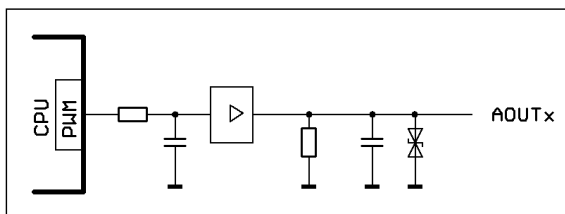

Analog Output Reference		
Input-Name	CoDeSys	
AOUT0	AnalogOutput0	%QW1
AOUT1	AnalogOutput1	%QW2

Temperature Measurement

The hipecs PLC12XX versions offer the special function of temperature measurement. The measurement methods (PT100/PT1000) can be independently chosen for each group. All Y connectors are identical.

Depending on your measuring method, you have to connect your PT100/PT1000 sensor according to the following tables.

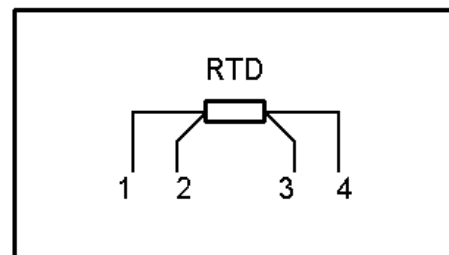
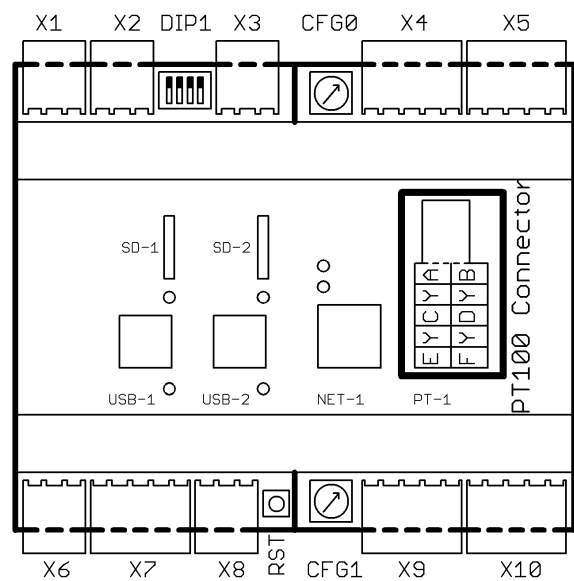

2 wire measurement (up to 6 channels in each group)

Kanal (RTD)	PT-Input						
	A	B	C	D	E	F	Y
1	1						4
2		1					4
3			1				4
4				1			4
5					1		4
6						1	4

2 wire measurement (up to 3 channels in each group)

Kanal (RTD)	PT-Input						
	A	B	C	D	E	F	Y
1	1	3					4
2			1	3			4
3					1	3	4

4 wire measurement (up to 2 channels in each group)

Kanal (RTD)	PT-Input						
	A	B	C	D	E	F	Y
1	1	2	3				4
2				1	2	3	4

DIP switch PT100/PT1000

DIP switch DIP 3 (group 0) / DIP 4 (group 1)				function
switch number				
1	2	3	4	
ON	x	x	x	PT1000 measurement
OFF	x	x	x	PT100 measurement
x	OFF	OFF	x	2-wire (4 channel)
x	OFF	ON	x	3-wire
x	ON	OFF	x	4-wire
x	ON	ON	x	2-wire (6 channel)
x	x	x	ON	6 msec Filter Time
x	x	x	OFF	100 msec Filter Time

For additional filter times check CANopen object "5308: Filter Time"

CoDeSys Configuration

Since the temperature module is an optional component for the hipecs PLC, it is embedded to the internal system by a internal CAN bus. To make the inputs available in CoDeSys, this internal CAN bus must be configured. Therefore, the eds-file for this module is required. This eds file named "hipecs_CIO-PLCPT01.eds" must be copied to the folder:

C:\Programme\3S Software\CoDeSysV2.3
 \Library\PLCConf\

Then choose the third CAN interface of the hipecs PLC and replace it with "CANopen Master...". After that append the sub element "hipecs CIO-PLCPT01". The module has a fixed baud rate of **500kBit/s** and the fixed **node Id 2**. The PDOs must be activated!

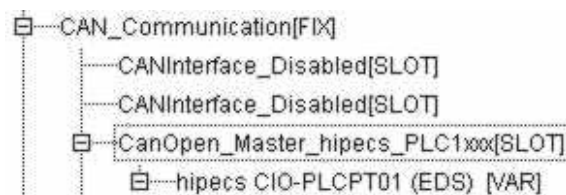
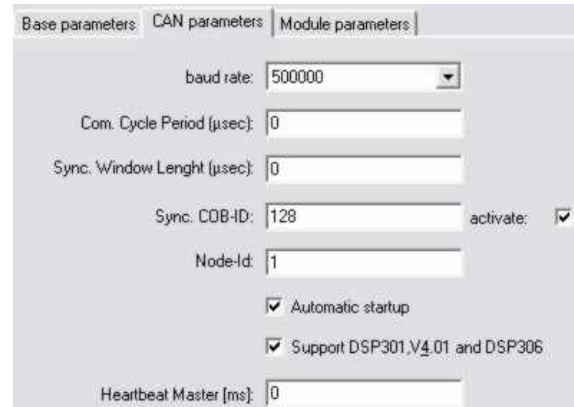

Advices for temperature measurement:

- It is recommended to **hot wire non used channels** in order to reduce interferences.
- The CANopen object "5304: Auto Disable Inactive Channels" or "5305: Force Disable Channels" may be used to **disable redundant channels**.
- It is recommended to **choose maximum possible filter time** to get more accurate values.

Attention!!

The temperature module is an optional component for the hipecs PLC which is internally connected via CANopen. There are several special functions available which are identical with the CANopen IO-module "hipecs CIO160i". Please refer to the CIO Object Datasheet for further information of these functions.

Connection

USB driver installation

After connecting the USB interface of your PC to the hipecs, your system will automatically find the PLC. Then choose manual installation and select the path, of your driver folder. Now your system should install 2 separate drivers. The first (lower) one is for the programming interface, the second (higher) driver is for the PC shell communication.

PC shell communication (Windows)

The hipecs supports a PC shell communication interface, so the user can establish a communication via the hypertext terminal. After starting the hyper terminal open a new connection:

Via USB connection:

name: XXX
connection: *your corresponding COM port*
baudrate: 9600
databits: 8
parity: none
stopbits: 1
flow control: none

If the hipecs is connected to a network:

name: XXX
connection: TCP/IP
hostaddress: *the IP address of your hipecs*
port: 23

For a complete list of available commands type "help" or "net help" for the network commands. Parameters that are changed via this shell communication are only valid until the next reset. If parameters shall be changed permanently, it is recommended to use the system.ini file.

FTP Server

For using the hipecs FTP server the following parameters have to be set in your browser:

IP: *The IP-address of your hipecs*
username: *admin (default)*
password: *admin (default)*

These parameters can be changed by manipulating the system.ini file. (see chapter system.ini)

system.ini configuration

With the system.ini file the network configuration can be set. The system.ini-file must be stored in the active drive in order to set the parameters permanently. If there is no system.ini found by the firmware, the default parameters are used. These parameters are available:

net.macaddress: *The MAC-Address of your system*
net.dhcp : *1 enables dhcp client / 0 disable*
net.ipaddress: *set system IP address*
net.subnetmask: *subnet mask*
net.gateway: *gateway IP address*
net.dnsserver.primary: *primary dns server*
net.dnsserver.secondary: *secondary dns server*

net.smtp.server: *servername or IP address of smtp server*
net.smtp.login: *login name for smtp server*
net.smtp.password: *password for smtp server*
net.smtp.sender.name: *sender name for email creation*
net.smtp.sender.email: *sender email address for email creation*

net.http.startdir: *select directory for web server data*

net.ftp.login: *name for FTP server login*
net.ftp.password: *password for FTP server login*

File System

The hipecs offers a file system to access the internal and external SD card drives. The internal SD Card is always accessed by "A:\". There are at least two folders by default in the internal SD drive. The folder "PLC" contains the CoDeSys bootproject named plcpp.exe which is created by the hipecs after downloading a bootproject. The folder "USR" is the standard user folder. Operations executed by the "FBESysFile" library are done within this directory by default.

Available Drives			
Drive name	Slot	Size	boot drive
A:\	internal	128MB	Yes
C:\	SD-1	max. 4GB	Yes
D:\	SD-2	max. 4GB	NO

Boot Loader and Firmware

The hipecs firmware is build up in two levels. The basic level is represented by the so called "Firmware Loader". When the hipecs is resetted or powered up, the Loader starts working first. The loader checks the installed firmware and searches the boot device for an optional file, called "firmware.bin". If this firmware-file is identical to the installed firmware, the firmware is started by the loader. By setting the CFG1 switch it is possible to prevent the firmware from starting. If the firmware.bin file is different from the installed one, the loader deletes the hipecs firmware and installs the firmware.bin file as new firmware.

!Attention!: If updating the firmware make sure, no file named firmware.bin is in the root directory of your boot drive. After restarting the device the old firmware will be installed again then.

This makes a firmware update possible by coping a newer firmware.bin file into the root directory of the boot drive.

It is possible to boot the hipecs from internal and external drives. See page 9 for configuration! So boot projects and system.ini configurations can be switched by exchanging the SD card. It is also possible to have different projects running with different firmware versions on different SD cards.

Command Shell

The command shell is provided by the hipecs firmware via the second serial USB interface. The driver installation creates two serial communication ports in the system. The lower one is used for CoDeSys login, the higher is for the command shell. For using the command shell it is necessary to create a connection via the hyperterminal. For Windows 7, there are free tools available. Check page 13 for setup information. Login via Telnet server is also supported. In this shell it is possible to work in a command line style and execute several commands. The most important will be mentioned here. By typing "help" a complete list will be displayed. Command shell work for Loader and firmware.

format <x>: <FAT> <N>:

format drive <x>, with either FAT16 or FAT32 or automatical, N = drive name with max. 8 characters. If the hipecs detects a SDhc Card >2GB, FAT32 is formatted, otherwise FAT16.

firmware backup <f>:

creates a backup of the actual firmware named <f>. If no filename is mentioned, default is firmware.bin. This file is searched by the Loader! Check left column (Bootloader)

set drive <d> <e>:

disable/enable a drive if it is not automatically enabled.

system restart loader:

restart system without starting firmware.

Attention! When typing filenames, a maximum of 27 characters may not be exceeded! Always use complete filename with correct path if coping across different folders.

(e.g. copy c:\test.txt a:\USR\copytest.txt)

Additional for loader:

firmware update <f>:

update existing PLC firmware from file <f>. If no name is mentioned, default file for updating is firmware.bin!

Programming in CoDeSys

CoDeSys installation

Note: If CoDeSys is already installed on your PC/Notebook start installation with Point 2).

System requirements:

- Pentium II, 500 MHz
 - 128 MB RAM (256 MB recommended)
 - 100 MB HD space
 - Windows 2000 or higher
 - CD ROM drive
- 1) Installation of CoDeSys development tool on your PC/Notebook.
 - Insert CoDeSys compact disk into the CD-ROM drive.
 - If setup boots not automatically, open CD-drive in the windows explorer. In explorer double-click SETUP.EXE.
 - If you have downloaded the CoDeSys programming system execute the `sw_codesys_v23xx.exe` file
 - Follow the instructions that appear on your screen.
 - 2) Install hipecs targets and libraries to your PC / Notebook.
 - Insert compact disk with targets and libraries into CD-ROM drive or download targets from www.frenzel-berg.de.
 - With CoDeSys installation the "Install Targets" program was installed.
 - Start "Install Targets" program.
 - Then press button OPEN (öffnen) and open the target information file *.tnf from the directory *Targets* on CD or the corresponding folder in which you downloaded the file.
 - Target must now be shown in the left window.
Do not change the path of targets destination. The entry looks like the following example:
"C:\CoDeSys\Targets\FBEI"
 - At last select the target in the left window and press button INSTALL (installieren).
 - The right window shows the installed targets.

For software development and testing, the CoDeSys programming system must be connected to the hipecs controller. This can either be done by using a network connection, a serial- or a USB-connection. Therefore the following parameters have to be set:

network connection

In the CoDeSys online / communication parameters settings a new TCP/IP (level 2) channel with these settings must be created:

Address: *The IP-address or hostname of your hipecs.* (check chapter "System.ini for standard hostname settings.)

Port: 1200 (This is mandatory!)

Blocksize: 128 (This is mandatory!)

Motorola byteorder: No

serial / USB connection

In the CoDeSys online / communication parameters settings a new serial (RS232) channel with these settings must be created

Port: *The corresponding COM-port of your USB-Interface or your serial connection*

Baudrate: 57600

Parity: even

Stop bits: 1

Motorola byteorder: no

Flow control: off

Measurements

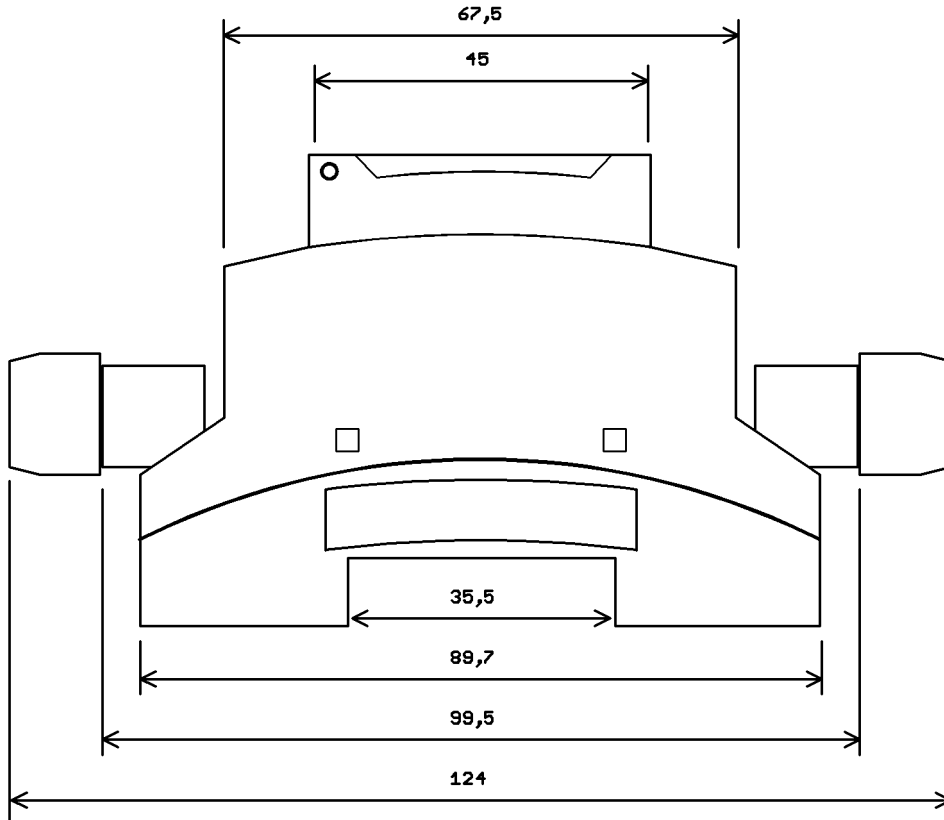

Dimensions including WAGO713 connectors

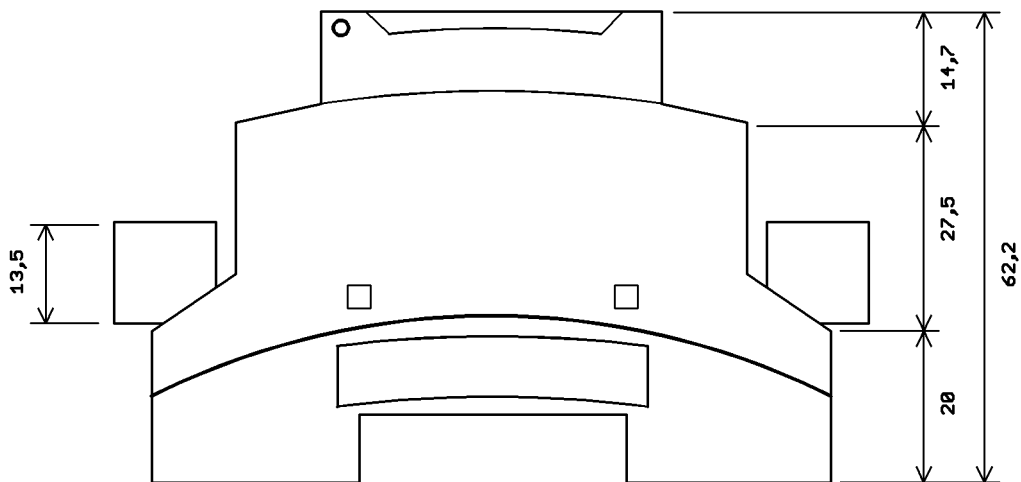

Measurement without connectors

all dimensions in mm

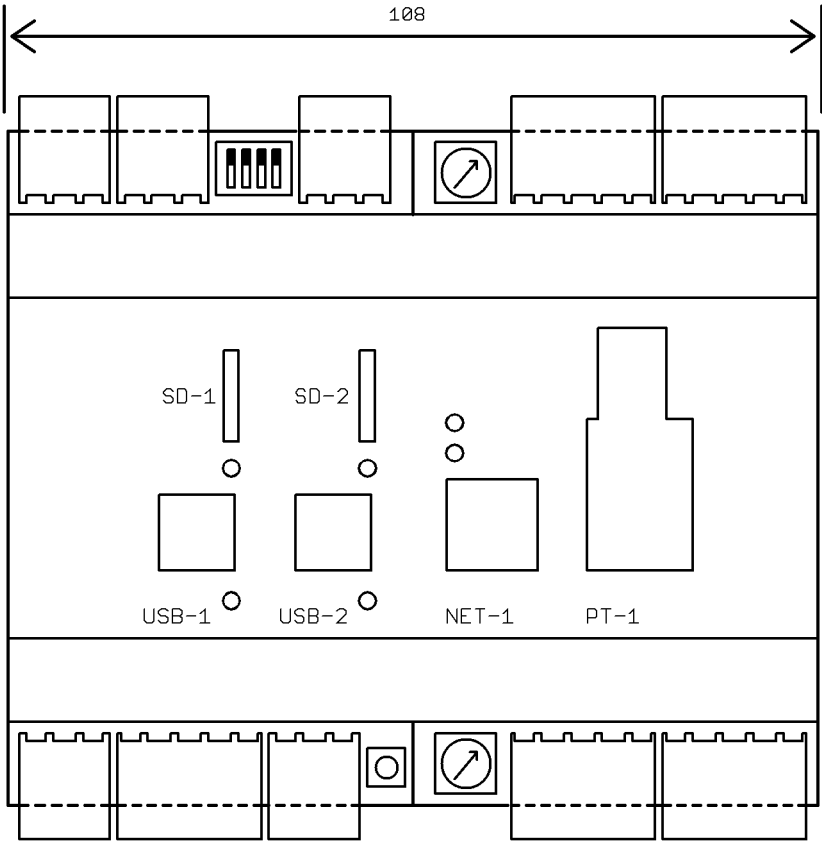

Measurement without connectors

all dimensions in mm

Version History and Notes

The following table shows all relevant changes of the device and datasheet during product life time.

Version	Date	Changes
1.000	July/20/2010	First version
1.000-R01	July/2010	Without comment
1.000-R02	October/20/2010	New photos (in work) and rework of pin assignment
1.000-R03	December/2010	I/O Description
1.000-R04	March/2011	CoDeSys installation and connection description / driver installation
1.000-R05	May/2011	Measurements of plastic housing added
1.000-R06	August/2011	Order Information added / pictures changed / IO description rework
1.000-R07	August/2011	reference overviews rework , technical specifications rework
1.000-R08	December/2011	changes to digital input levels / added PLC1030 ordering information
1.000-R09	January/2012	DIP-Switch description added, rework of connection setting and FTP password
1.000-R10	February/2012	file system description
1.100-R0	February/2013	Added PT100/PT1000 description / added an additional top view for connectors
1.100-R1		Changed top view measurements
1.100-R2	March/2013	Added COM3 / SGI description
1.450-R2	August/2013	reworked connectors top view / corrected mistake
1.490-R1	December 2013	corrected wrong encoder and interrupt description 3 encoder channels A/B + 1 channel for counter / 6 IRQ

Attention please !

All rights reserved.

The information herein is given to describe certain components and shall not be considered as warranted characteristics. Terms of delivery and all rights to technical changes are reserved.

We hereby disclaim any and all warranties, including but not limited to warranties of non-infringement, regarding circuits, descriptions and charts stated herein.

The electronic product described in this document is designed, developed and manufactured as contemplated for general use, including without limitation, ordinary industrial use, general office use, personal use, and household use, but is not designed, developed and manufactured for use in applications accompanying fatal risks or dangers that, could have a serious effect to the public, and could lead to death, personal injury, severe physical damage or other loss (i.e., nuclear reaction control in nuclear facility, aircraft flight control, air traffic control, mass transport control, medical life support system, missile launch or flight control or in weapon system).

The product is not designed, developed and manufactured for applications requiring extremely high reliability (i.e., submersible repeater and artificial satellites).

Please note that frenzel + berg electronic GmbH & Co.KG will not be liable against you and/or any third party for any claims or damages arising in connection with above-mentioned uses of the products.

Any electronic products and/or semiconductor devices have an inherent chance of failure. You must protect against injury, damage or loss from such failures by incorporating safety design measures into your application, facility and equipment such as redundancy, fire protection, and prevention of over-current levels and other abnormal operating conditions.

The product described herein is not UL rated.

Table Of Contents

General Description	1	system.ini configuration	15
Ordering Information	1	File System	16
PLC features	2	Boot Loader and Firmware	16
CANopen features.....	2	Command Shell	16
VISU features.....	2	Programming in CoDeSys	17
PT100/PT1000 Temperature Mesurement.....	3	CoDeSys installation.....	17
Interrupt features.....	3	network connection	17
Encoder Interface.....	3	serial / USB connection.....	17
Event Counter	3	Measurements	18
Serial Interfaces	3	Version History and Notes	20
USB.....	3	Attention please !	20
Ethernet	3	Table Of Contents	21
Additional features	3		
SD-Card slot.....	3		
Customer features.....	3		
Technical Data	4		
Connectors	7		
X1 CAN0	7		
X2 CAN1	7		
X3 COM1-2	7		
X4 Digital Input Group 1	7		
X5 Digital Input Group 0	8		
X6 SGI (RS422/485)	8		
X7 Analog In-/Output.....	8		
X8 Main Power Supply (logic/CPU).....	8		
X9 Digital Output Group 0	8		
X10 Digital Output Group 1	8		
USB-1 USB-Interface	9		
NET-1 Ethernet-Interface	9		
PT-1 (PT100/PT1000 connectors)	9		
LED's	10		
DIP-Switch and CFG-Switches	10		
Digital Inputs	11		
Using Standard Digital Inputs.....	11		
Using Encoder Inputs.....	11		
Using Interrupt Inputs.....	11		
Digital Outputs	12		
Using Standard Digital Outputs	12		
Using PWM Outputs.....	12		
Using Stepper Motor Outputs.....	12		
Analog Inputs and Outputs	13		
Analog Inputs	13		
Analog Output	13		
Temperature Measurement	13		
DIP switch PT100/PT1000	14		
CoDeSys Configuration.....	14		
Connection	15		
USB driver installation.....	15		
PC shell communication (Windows).....	15		
FTP Server.....	15		