

General Description

The CO4011 is a low cost, high performance Single Chip solution for CANopen remote I/O modules and especially designed for automotive and industrial applications. The device offers the complex implementation of the CANopen standards DS301 and DS401 in a single chip. It is suitable for simple low cost applications like sensor interfacing as well as for complex I/O systems.

CO4011 provides up to 32 digital I/O lines, 0, 4 or 8 channels may be set for analog input operation with a resolution of 8 or 10 bit. To support output overload monitoring, a special error interrupt input is provided. All usual baud rates up to 1 MBit are supported.

The CO4011 Chip requires only few external components, just like a crystal, a CAN transceiver and capacitors. To minimize external interface recommendations all output pins have high current drive capability of 4 mA. For interfacing optoisolators no external drivers are required.

CO4011 is a software solution to run on Fujitsu MB90F497 micro controller. It is offered either as software runtime licence or as ready programmed chip (runtime licence included).

Features

- **Single Chip CANopen Controller**
- **According to CiA Draft Standards DS301 Version 4.0 and DS401 Version 2.0**
- **Baudrate up to 1MBit**
- **Various I/O configurations**
- **Internal noise filtering for all inputs with individual setting for each channel**
- **Error interrupt input for output overload monitoring**
- **Output drivers with 4mA**
- **Watchdog output**
- **Temperature ranges up to -40 to 105 °C**
- **Package QFP64**

Applications

The CO4011 CANopen Controller is optimised for automotive and industrial applications such as:

- **Remote I/O Modules for CANopen**
- **CANopen Interface for keyboards and control panels**
- **Low Cost CANopen Interface for sensors like photoelectric reflex switches photo interrupters**
- **Low Cost CANopen Interface for actors like pneumatic valves, warning panels etc.**



CANopen Features

- **2 Transmit- and 1 Receive PDOs**
- **Dynamic PDO mapping**
- **Variable PDO identifier**
- **All CANopen specific PDO transmission types supported:**
synchronous, asynchronous, event driven, cyclic, acyclic and remote frame dependent.
- **Additional manufacturer specific transmission mode for CAN-EASY applications.**
- **Event timer and inhibit timer features for all transmit PDOs.**
- **Storing and restoring of object dictionary to non-volatile memory**
- **Nodeguarding**
- **Lifeguarding**
- **Heartbeat**
- **Variable SYNC identifier**
- **Emergency messages**
- **Minimum boot up**

Ordering Information

CO4011 Chip (programmed, licence included)

Part	Temp. Range	Package
CO4011A-FL	-40 °C to 85 °C	QFP64
CO4011AE-FL	-40 °C to 105 °C	QFP64

Software licence

Part	Description
CO4011SRL-F	Software runtime licence for Fujitsu MB90F497 controller

Pin Assignment

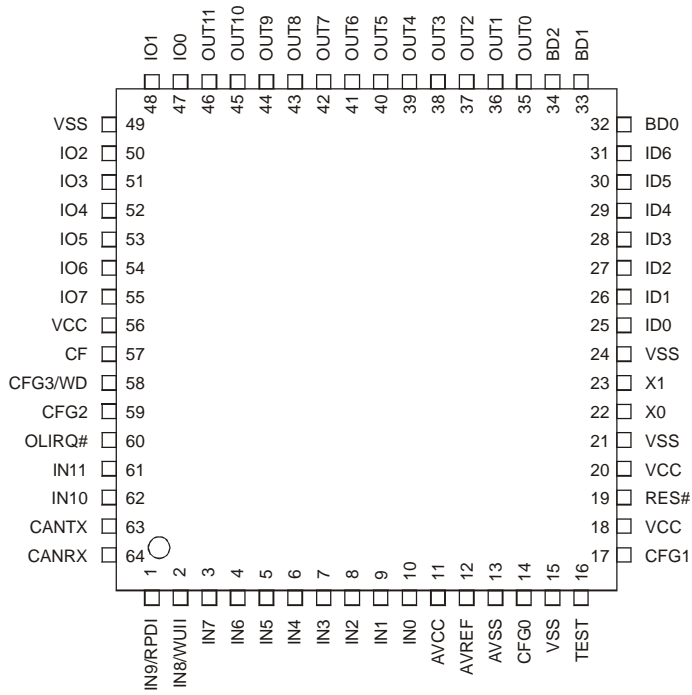

Pin Listing continued

Pin No.	Pin Name	Funktion
25*, 26*, 27 to 31	ID0*, ID1*, ID2 to ID6	Identifier selection input
32 to 34	BD0 to BD2	Baud rate selection input
35 to 46	OUT0 to OUT11	Digital output active low
47, 48, 50 to 55	IO0 to IO7	Digital input or output according to configuration setting. Active low
57	CF	Filter capacitor
60*	OLIRQ# *	Output overload interrupt input active low
61, 62*	IN11, IN10*	Digital input
63	CANTX	Transmitter output of CAN module
64	CANRX	Receiver input of CAN module
15, 21*, 24, 49	VSS	Ground
18*, 20, 56	VCC	Power supply

* Pins may be used for in circuit programming. See "in circuit programming manual" for further information

Pin Listing

Pin No.	Pin Name	Funktion
1 to 2	IN9 to IN8	Digital input active low IN8 additional feature: Wake Up Interrupt Input IN9 additional feature: Reset Power Down Input
3 to 10	IN7 to IN0	Analog or digital input according to setting of CFG0 .. CFG3 active low
11	AVCC	Supply for A/D-Converter
12	AVREF	Reference Voltage for A/D-Converter
13	AVSS	Ground for A/D-Converter
14, 17, 59	CFG0 to CFG2	Configuration bits 0 to 2 for I/O setting / LED output
58	CFG3	Enable additional CAN features input and watchdog output
16	TEST	Do not connect this pin
19	RES#	Reset input active low
22	X0	Crystal oscillator input
23	X1	Crystal oscillator output

Handling the Device

Preventing latch up

The CO4011 is a CMOS device and may suffer latch up under the following conditions:

- 1) A voltage higher than VCC or lower than VSS is applied to any pin.
- 2) Absolute maximum ratings are exceeded
- 3) AVCC power is provided before VCC supply

Handling unused Pins

Do not leave unused input pins open. This might cause malfunction of the device.

Power Supply Pins

Make sure that all ground and power supply pins are connected to the same potential. Do not leave any ground or power pins open. Connect at least two ceramic capacitors of 100 nF and a tantalum capacitor of 1 uF between VCC and VSS as close as possible to the device.

Power Supply for A/D converter

The power supply for the A/D converter must not be turned on before the power supply VCC. If the A/D converter is not used, connect the pins as follows: AVCC = AVREF = VCC, AVSS = VSS.

Input / output pins

All input and output pins for digital signals are active low. This means for input pins, that inverted pin level is mapped to PDO. For output pins the inverted byte value from received PDO is written to the output pins. Additional inverting capabilities are supported.

Pull up/down resistors

The CO4011 does not support internal pull up/down resistors. Use external components where needed.

Pin Description

All input / output pins are high impedance during reset. The CO4011 does not support internal pull up/down resistors. Use external components where needed. All input pins have Schmitt trigger characteristics. See chapter "Typical Applications" for additional information.

IN0 to IN11: Digital or analog input pins

The function of IN0 to IN7 depends on setting of configuration bits CFG0 to CFG2. See also chapter "Mapping I/O to Object Dictionary" for details.

Note: Digital input pins are active low. This means that digital input pins are mapped with inverted values to transmit PDO data.

All digital inputs use internal Schmitt trigger circuits. The CO4011 provides optional input inverters and internal noise filtering for all inputs with individual setting for each channel. See chapter "Object Dictionary" for details.

OUT0 to OUT12: Digital output pins

All output pins have high current drive capabilities of approximate 4 mA for direct interfacing for optocouplers without additional drivers.

Note: Digital output pins are active low. This means that received output data from PDO is written with inverted values to output pins.

The CO4011 provides optional output inverters with individual setting for each channel. See chapter "Object Dictionary" for details.

IO0 to IO7: Digital input or output pins

The function of IO0 to IO7 depends on the setting of CFG2. See also chapters "Device Configuration" and "Mapping I/O to Object Dictionary" for details. For IOx the description of INx or OUTx is valid, dependant to CFG2 setting.

CF: Filter Capacitor input

For correct operation of the CO4011 a ceramic capacitor of 100 nF or 220 nF must be connected between Pin 57 (CF) and VSS. Place this component as close as possible to the CO4011.

X0, X1: Crystal oscillator input

Connect a crystal of 4 MHz between X0 and X1. Use additional ceramic capacitors of 22 pF between X0 and X1 to VSS.

TEST: Reserved pin

Leave pin TEST unconnected.

OLIRQ#: Output Overload Interrupt

This active low input pin is provided to support output overload monitoring. Connect output from output overload control circuit to this input pin. If the CO4011 scans a low level on pin OLIRQ#, the device automatic enters the error state given in Object 67FE.02 (default enter preoperational state).

Further more the Error Register (index 1001) is set to 0x03, indicating a current error.

Last but not least the device will send an emergency telegram with error code 0x2310 indicating an overload error.

If output overload monitoring is not to be used in your application, make sure, that pin OLIRQ# is forced to logic high level.

VCC, AVCC, VSS, AVSS: Power Supply Pins

Make sure that all ground and power supply pins are connected to the same potential. Do not leave any ground or power supply pins open. Connect decoupling capacitors as close as possible to the device. See chapter "Recommended Operation Conditions" for details

RES#: Reset input pin

For a correct device reset, provide an active low reset signal according to recommended operation conditions to input RES#.

CFG0 to CFG2: Configuration input pins / LED output pins

Set device configuration to preferred operation mode using CFG0 to CFG3. Leaving any configuration input unconnected may cause malfunction of the device. It is strongly recommended forcing all configuration input bits to either high or low level by using external pull up/down resistors. Do not use direct connection to VCC or VSS.

LED-Functions (active low):

CFG0 Chip-Status LED shows the Chip status
Always blinking:

10 % Duty cycle indicates no error

90 % Duty cycle indicates error

CFG1 CANopen RUN LED shows NMT state
according to DRP303-3

CFG2 CANopen Error LED shows Error state
according to DRP303-3

Note: CFGx are input pins during start up and output pins in normal operation mode. In order to prevent short circuit overload a series resistor between CFGx and configuration device (example DIP switch) should be used. See also "typical application" for details.

CFG3/WD: Configuration input / watchdog output

CFG3/WD is scanned during reset to switch the CO4011 to enable additional CAN features. Then CFG3/WD is switched to output and drives the watchdog trigger. To monitor correct device operation, this feature may be used in combination with an external watchdog timer.

Note: CFGx are input pins during start up and output pins in normal operation mode. In order to prevent short circuit overload a series resistor between CFGx and configuration device (example DIP switch) should be used. See also "typical application" for details.

CANRX, CANTX: CAN interface pins

The CAN interface pins may be used for direct connection to CAN transceivers like the 80C251. For longer bus length or noisy or disturbed environments it is strongly recommended to use galvanic isolation with optocouplers between bus interface and CANopen application, to improve system reliability.

In Circuit programming of MB90F497

If you want to enable in circuit programming of the Fujitsu MB90F497 micro controller for CO4011 software download or update, the following conditions must be met.

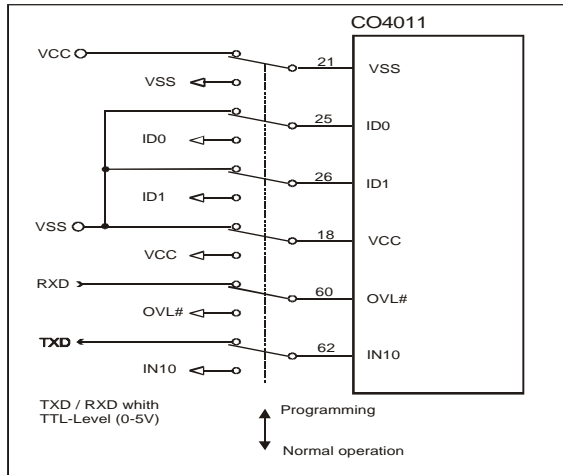

Pin No.	Pin Name	Pin Setting for in circuit programming
21	VSS	Level = High
18	VCC	Level = Low
25	ID0	Level = Low
26	ID1	Level = Low
60	OVL#	RXD (TTL – logic level)
62	IN10	TXD (TTL – logic level)

Design example for programming adaptor.

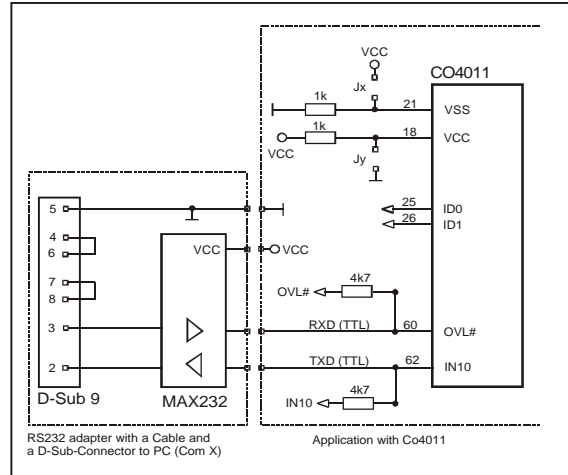

To enable the programming condition chose an identifier that forces the Pins ID0 and ID1 to low level. For example identifiers ID= 3, 7, 0x0B, 0x0F ... might be used. Close the jumpers Jx and Jy.

For optimised programming adaptor design, the programming adaptor should close the jumpers Jx and Jy directly by plugging the adaptor into the application board.

For normal operation mode the programming adaptor must be removed.

Device Configuration

The following sections describe the device configuration with meaning:

- 1: ViH logic high level
- 0: ViL logic low level

CAN Identifier

The CAN Identifier will be set with Pins ID0 to ID6. This configuration pins use internal inverter. The ID is set as follows:

ID6	ID5	ID4	ID3	ID2	ID1	ID0	CAN-Identifier
1	1	1	1	1	1	1	Programmable ID
1	1	1	1	1	1	0	1 = 0x01
1	1	1	1	1	0	1	2 = 0x02
1	1	1	1	1	0	0	3 = 0x03
1	1	1	1	0	1	1	4 = 0x04
		
1	0	0	0	0	0	0	63 = 0x3F
0	1	1	1	1	1	1	64 = 0x40
0	1	1	1	1	1	0	65 = 0x41
		
0	0	0	0	0	1	0	125 = 0x7C
0	0	0	0	0	0	1	126 = 0x7E
0	0	0	0	0	0	0	127 = 0x7F

All Identifiers from 1 to 127 are valid settings. Identifier 0 is used to load the ID from object 2100.

Baud rate

The baud rate configuration will be done with configuration inputs BD0 to BD2

BD2	BD1	BD0	CAN-Baud Rate / Bus length
1	1	1	1 Mbit/sec 25 m *1)
1	1	0	800 kbit/sec 50 m *1)
1	0	1	500 kbit/sec 100 m *2)
1	0	0	250 kbit/sec 250 m *2)
0	1	1	125 kbit/sec 500 m *3)
0	1	0	50 kbit/sec 1000 m *3)
0	0	1	20 kbit/sec 2500 m *3)
0	0	0	10 kbit/sec 5000 m *3)

- *1) Calculation without optocouplers. For optocouplers bus length is reduced for about 4m per 10 nsec propagation delay of employed optocoupler type
 - *2) Calculation with 40 nsec optocoupler propagation delay
 - *3) Calculation with 100 nsec optocoupler propagation delay
- The calculation of the bus length is based on a line propagation delay of 5 nsec/m.

Analog Input Selection

With configuration bits CFG0 and CFG1 the number and resolution of analog inputs are set.

CFG1	CFG0	Nr of analog channels	Resolution	Analog Inputs	Digital Inputs
1	1	0	-	-	IN0 to IN11
1	0	8	8 Bit *1)	IN0 to IN7	IN8 to IN11
0	1	4	10 Bit *2)	IN 0 to IN 3	IN4 to IN11
0	0		Reserved		

- *1) The analog inputs are mapped as unsigned 8 values into a single transmit PDO (TPDO2).
- *2) The analog inputs are mapped as signed 16 values into one transmit PDO (TPDO2).

If analog inputs are enabled, the corresponding input channels are not scanned for digital signals. The digital input signals for those channels are always set to 0 without taking care of the analog input level. If analog inputs are disabled (CFG1 = 1, CFG0 = 1) the analog input voltage of input IN0 to IN3 is not scanned.

Do not apply higher voltages than VCC and AVCC to any input pin. If the A/D converter is not used, connect the power supply pins as follows: AVCC = AVREF = VCC, AVSS = VSS.

Configuration of IO-Port

Device pins IO0 to IO7 may be used as digital inputs or digital outputs. This selection must be done with CFG2. See also section "Mapping I/O to Object Dictionary" for additional information

CFG2	I/O Port is used for
1	Digital Input
0	Digital Output

Enable additional CAN features

With setting CFG3 to 0 the following special features may be enabled:
 - Easy Mapping of Objects to PDO

CFG3	I/O Port is used for
1	Normal operation mode
0	Enable additional features.

These features might be incompatible with CANopen conformance Test.

Power Down Mode

During power down, the CO4011 stops working completely. The oscillator is stopped. The CO4011 keeps its NMT state (operational, preoperational).

The complete power down extension is switchable on and off, so that the same chip can be used for standard applications as well.

In power down configuration a Wake-Up-Interrupt-Input (WUII pin2) can be used for wake up by CAN bus line and optional an additional Reset-Power-Down-Input (RPDI: pin1) may be used for system wake up by a push button or something like that. Both inputs are active low. WUII must be directly connected to CANRX (pin 64) on the application board if wake up by CAN bus line (telegram) is wanted.

A counter is implemented which counts the number of the return from power down operations.

All output lines keep unchanged during the power down state.

For power down control 6 objects are added to the object dictionary of the CO4011:

Power-Down Enable
Switch to Power-Down Mode
Reset Power Down Input Enable
Wake Up Counter
Power-Down Delay Time
Wake-Up-Confirm-Time

Activate Power-Down

To enable the power down mode the following actions are necessary

The object Power-Down-Enable (2FFE) has to be written to with the signature 0x5044454E ("PDEN"). With that the pin WUII is configured at the same time. The signature can be written by SDO transfer but it may also stay saved together with the object dictionary in the chips non-volatile memory.

The activation of Power-Down is done by writing the signature 0x504F4646 ("POFF") to the object "Switch to Power-Down-Mode" (2FFF). This access must be done by SDO transfer.

After the CO4011 has recognized a power down instruction, it is waiting until the SDO answer telegram was sent to the bus. After an additional waiting time corresponding to the "Power-Down Delay Time" object, the CO4011 switches in power-down mode.

If Object "Power Down with Stop Node" (2FF9) is set to its valid signature 0x454E534E, the Chip is also switched to Power down with the NMT Telegram Stop Node.

Return from Power-Down

If pin WUII (Wake-Up-Interrupt-Input) is connected to CANRX the CO4011 can be waked up by any CAN telegram. Even a level change on the CAN bus line is enough.

The CO4011 restarts the CAN module after handling the interrupt and scans incoming telegrams. If a valid NMT telegram is received on identifier 0 during a time out corresponding the "Wake-Up-Confirm-Time" object, the CO4011 switches back to normal operation mode. Otherwise the power down state is activated again.

Attention:

Because of the different start up times of the oscillator during wake up it could happen, that the CO4011 already interprets the wake up telegram as a valid CAN message. This can not be guaranteed. That's why an identifier should be selected for wake up, which isn't used by a CAN message in the application.

An emergency telegram is sent during wake up by Reset Power Down Input pin and so the normal run is started up without any additional CAN message needed.

The wake up counter is incremented by each wake up event. That is irrespective of whether a correct NMT telegram also will be recognized or not after a wake up interrupt by CAN bus. Therefore a definite handling how many wake up events were done is possible.

Emergency-Message

The CO4011 sends the emergency telegram after wake up by pin "Reset Power Down Input" with the following content:

Error-Code	0xF000
Error Register	0x01
Manufacturer specific Error Field	0

After an additional waiting time which corresponds to the "Wake-Up-Confirm-Time" object, an additional emergency telegram with content 0 is sent. This indicates the reset of all errors.

Object Dictionary

The CO4011 Single Chip CANopen Controller implements a complex object dictionary for CANopen I/O devices.

For detailed information about CANopen objects see additional brochure "Introduction to CANopen"

For the Object tables all values are shown in hexadecimal way.

For access type the following settings are valid

ro read only

wo write only

rw read and write access enabled

DS301: global Objects

Index	Sub-Index	Name	Acc.
0005	-	Dummy 8	ro
0006	-	Dummy 16	ro
0007	-	Dummy 32	ro
1000	-	Device Type	ro
1001	-	Error Register	ro
1002	-	Manufacturer Status Register	ro
1005	-	COB-ID Sync Identifier Sync Object	rw
1008	-	Device Name *2)	rw
1009	-	Hardware Version *2)	rw
100B	-	Node Id	ro
100C	-	Guard Time	rw
100D	-	Life Time Factor	rw
100E	-	COB-ID Guard	rw
1010	-	Store Parameters *1)	wo
1011	-	Reload Default Parameter *1)	wo
1014	-	COB ID Emergency	rw
1015	-	Inhibit Time Emergency	rw
1017	-	Producer Heartbeat Time	rw
1018	0	Identity Object	ro
	1	Vendor ID	ro
	2	Product Code	ro
	3	Revision Number	ro
2000	-	Device Manufacturer *3)	ro
2100	-	New Node Id *4)	rw
2101	-	System Configuration	ro
2102	-	New Baud Rate *5)	rw
2110	-	Enable Boot Up Message	rw
2180	-	CAN Restart Time	rw

Notes:

- *1) This object cannot be written to in operational device state.
Only use this command in preoperational device state, otherwise the CO4011 will answer requests with SDO abort telegrams.

- *2) This objects are enabled for read/write access in order to give OEMs the possibility to ship their own hardware based on the CO4011A with individual device names and hardware versions.
- *3) This Objects shows "Frenzel + Berg" as visible string data type. If OEMs do not want to give access to this entry, it may be removed from the EDS (electronic data sheet).
- *4) The New Node Id object gives the possibility to set a Node-Nr independent from the Node-Id Input Bits. With this feature the device may be configured by CAN bus line.
- *5) The New Baud Rate object gives the possibility to set a baud rate independent from the baud rate input bits. With this feature the device may be configured by CAN bus line.
This feature will not be implemented in the first step of the device

The data type entries Index 0005 to 0007 are implemented for compatibility reasons. They may be mapped to PDOs in order to define the appropriate space in the PDO.

For the read only objects following data is set:

Index	Sub.	Name	Value in Hex.
1000		Device Type	0007 0191 h
1018	0	Identity Object	03h
	1	Vendor ID	0000 0058 h
	2	Product Code	0104 0111 h
	3	Revision Number	0 .. 0xFFFFFFFF
2101		System Configuration	Set according to the setting of the configuration input bits.

DS301: PDO Parameter Objects

Description of PDO Parameter objects:

These Objects enable dynamic PDO mapping, variable identifier distribution for PDOs and setting of the transmission mode, inhibit and event times.

For the CO4011 setting of all parameters may be done in the device state "operational" as well as in "preoperational" state.

Index	Sub-Index	Name	Acc.
1400	0	Receive PDO1 Communication Parameter	ro
	1	COB-ID	rw
	2	Transmission Type	rw
	3	Inhibit Time (not used)	rw
	4	Reserved	rw
	5	Event Timer	rw
1401 ... 1403		Receive PDO2 to RPDO4 Communication Parameter same as 1400.00 .. 1400.05	rw
1600	0	Receive PDO1: Parameter mapping	rw
	1 to n	Mapped Object (max. 8 objects mappable)	rw
1601 ... 1603		Receive PDO2 to RPDO4 Parameter mapping Same as 1600	rw
1800	0	Transmit PDO1 Communication Parameter	ro
	1	COB-ID	rw
	2	Transmission Type	rw
	3	Inhibit Time	rw
	4	Reserved	rw
	5	Event Timer	rw
1801 ... 1803		Transmit PDO2 to TPDO4 Communication Parameter same as 1800.00 .. 1800.05	rw
1A00	0	Transmit PDO1 Parameter mapping	rw
	1 to n	Mapped Object (max. 8 objects mappable)	rw
1A01 ... 1A03		Transmit PDO2 to TPDO4 Parameter mapping Same as 1A00	rw

Note:

The CO4011A supports only 1 receive and 2 transmit PDOs. All Objects for higher PDO numbers are not implemented.

Note:

For detailed information about CANopen objects see additional brochure "Introduction to CANopen"

DS401: Digital Input Objects

Index	Sub-Index	Name	Acc.
5001	0 to n	Write 1 to digital input 8 bit	rw
5002	0 to n	Write 0 to digital input 8 bit	rw
5003	0 to n	Filter time for each digital input	rw
6000	0 to n	Read digital input 8 bit	ro
6002	0 to n	Polarity input 8-bit	rw
6003	0 to n	Filter constant enable 8 bit	rw
6005		Global interrupt enable	rw
6006	0 to n	Interrupt mask: any change	rw
6007	0 to n	Interrupt mask rising edge	rw
6008	0 to n	Interrupt mask falling edge	rw
6100	0 to n	Read digital input 16 bit	ro
6120	0 to n	Read digital input 32 bit	ro

The objects 5001 and 5002 are implemented for debug purposes, because the CANopen object 6000 does not allow write access to an input line. With objects 5001 and 5002 a debug environment may simulate setting or resetting of input lines. The CO4011 first scans the physical input lines and then processes the scanned values with the debug parameters.

Index 5001 and 5002 make direct bit manipulation of single bits possible.

Index 5001 enables bit setting by using a bit wise logical OR conjunction with index 6000 while index 5002 performs a logical AND conjunction with index 6000 and therefore enables resetting of single bits.

Objects 5001 and 5002 are always working in continuous execution mode. This means that logical operations with object 6000 are performed in each internal input scan cycle

With object 5003 an individual filter constant (value in msec) may be assigned to each input line. This gives great flexibility to prevent inputs from distortion. The default value for filter constant is 5msec. The filter constants enable object is at index 6003.

DS401: Digital Output Objects

Index	Sub-Index	Name	Acc.
5200	-	Reset Output on Error Option	rw
6200	0 to n	Write Output 8 Bit	rw
6202	0 to n	Change Polarity Output 8 bit	rw
6206	0 to n	Error Mode Output	rw
6207	0 to n	Error State Output	rw
6300	0 to n	Write digital output 16 bit	wo
6320	0 to n	Write digital output 32 bit	wo

DS401: Analog Input Objects

Index	Sub-Index	Name	Acc.
6400	0 to n	Read Analog Input 8 Bit *1)	ro
6401	0 to n	Read Analog Input 16 Bit *2)	ro
6421	0 to n	Analog Input Interrupt Trigger	rw
6423		Analog Input global Interrupt Enable	rw
6424	0 to n	Analog Input Upper Limit	rw
6425	0 to n	Analog Input Lower Limit	rw
6426	0 to n	Analog Input Interrupt Delta	rw
6427	0 to n	Analog Input Interrupt Negative Delta	rw
6428	0 to n	Analog input interrupt positive delta	rw
6431	0 to n	Analog input offset integer	rw

*1) These objects are only valid for configuration bits CFG1= 1 and CFG0= 0

*2) These objects are only valid for configuration bits CFG1= 0 and CFG0= x

Additional Objects for Power Down

Index	Sub-Index	Name	Acc.
2FF9	0	Power Down with Stop Node	Rw
2FFA	0	Wake Up Confirm Time	Rw
2FFB	0	Power Down Delay Time	rw
2FFC	0	Wake Up Counter	rw
2FFD	0	Reset Power Down Input Enable	rw
2FFE	0	Power Down Mode Enable	rw
2FFF	0	Switch To Power Down Mode	rw

Description of Object Dictionary

The following list gives da short description of all dictionary entries.

Index 0005

This object is implemented to enable reservation of data space in PDOs by mapping dummy entries.

Index	0005
Name	Dummy 8
Description	
Data Type	Unsigned 8
Access modes	RO
PDO Mapping	Yes
Value Range	-
Default Value	0

Index 0006

This object is implemented to enable reservation of data space in PDOs by mapping dummy entries.

Index	0006
Name	Dummy 16
Description	-
Data Type	Unsigned 16
Access modes	RO
PDO Mapping	Yes
Value Range	-
Default Value	0

Index 0007

This object is implemented to enable reservation of data space in PDOs by mapping dummy entries.

Index	0007
Name	Dummy 32
Description	-
Data Type	Unsigned 32
Access modes	RO
PDO Mapping	Yes
Value Range	-
Default Value	0

DS301: Global Objects

Index 1000 : Device Type

Description of the device type. The Object gives the CiA device profile number and additionally the functionality of the device.

Index	1000h	
Name	Device Type	
Description	-	
Data Type	Unsigned 32	
Access modes	RO	
PDO Mapping	No	
Value Range	-	
Default Value	Operation Mode	Value of Index
	CO4011A0	0003 0191 h
	CO4011A1	0007 0191 h
	CO4011A2	0007 0191 h
	CO4011A4	0003 0191 h
	CO4011A5	0007 0191 h
	CO4011A6	0007 0191 h

Index 1001 : Error Register

This object holds an error of the device.

Index	1001h
Name	Error Register
Description	-
Data Type	Unsigned 8
Access modes	RO
PDO Mapping	Yes
Value Range	-
Default Value	-

The error register has the following structure

Bit	Meaning
0	Generic error. This bit is set, if any error is active
1	0
2	0
3	0
4	CAN bus or communication error
5	0
6	0
7	Device Error

Index 1002 : Status Register

This object gives additional information for the device

Index	1002h
Name	Status Register
Description	-
Data Type	Unsigned 32
Access modes	RO
PDO Mapping	Yes
Value Range	-
Default Value	-

The status register bits have the following meaning

Bit	Meaning
31	The device is in operational state
30	Node guarding error
23	I/O error output overload error

Index 1005 : COB-ID Sync

Identifier of Can Object for the Synchronisation message. The CO4011 may only operate in Sync consumer mode. Generating of Sync messages is not possible. Nevertheless is the Identifier for the Sync message programmable.

Index	1005h
Name	COB-ID Sync
Description	-
Data Type	Unsigned 32
Access modes	RW
PDO Mapping	No
Value Range	-
Default Value	-

Index 1008 : Device Name

This object shows the name of the device as visible string.

Index	1008h
Name	Device Name
Description	-
Data Type	Visible String
Access modes	RW
PDO Mapping	No
Value Range	The maximum string length is 20 characters
Default Value	CO4011A

This object is enabled for read/write access in order to give OEMs the possibility to ship their own hardware based on the CO4011A with individual device names.

Index 1009 : Hardware Version

This object shows the name of the device as visible string.

Index	1009h
Name	Hardware Version
Description	-
Data Type	Visible String
Access modes	RW
PDO Mapping	No
Value Range	The maximum string length is 20 characters
Default Value	-

This object is enabled for read/write access in order to give OEMs the possibility to ship their own hardware based on the CO4011A with individual Hardware Version string.

Index 100B : Node-ID

This object keeps the actual node Id. The Object is not represented in the object dictionary because of standard conforming reasons.

Index	100Bh
Name	Node ID
Description	-
Data Type	Unsigned 8
Access modes	Not accessible
PDO Mapping	No
Value Range	1 to 127
Default Value	See below

There are several modes to select a valid node ID. Setting the configuration input bits ID0 to ID6 to any combination other than zero will take the configuration input setting of bits ID0 to ID6 as valid Node-ID.

If setting the configuration input bits ID0 to ID6 to the combination zero (all input bits at high level) will activate the Node-ID object 2100h. With this object a Node-ID may be set independent from the configuration input bits. If Object 2100h has value 0 (default factory setting if not written to by your application or CANopen configuration tool) the Node ID will be forced to 126 (7Eh).

For applications without any configuration switches the following configuration method must be used:

- All configuration input bits ID0 to ID6 must be forced to HIGH level. This will select Node-ID 0 (zero).
- When starting the device for the first time the Node ID will be set to 126 (7Eh).
- Now the Object 2100h may be set to the desired Node ID by using a CANopen configuration tool.
- The last step is to save this setting by using object 1010h.

If the device will be restarted the Node ID will be taken from object 2100h and will be copied to object 100Bh. Additionally the COB-Ids for the Sync-, Emergency-, SDO- and PDO- messages will be modified according to the new Node ID.

Index 100C : Guard Time

The objects at index 100Ch (Guard Time in milliseconds) and 100Dh (Life Time Factor) are used to implement the life guarding protocol. The Guard Time multiplied with the Life Time Factor gives the Life Time in milliseconds.
It is 0 (zero) if not used.

Index	100Ch
Name	Guard Time
Description	-
Data Type	Unsigned 16
Access modes	RW
PDO Mapping	No
Value Range	
Default Value	0

Index 100D : Life Time Factor

The objects at index 100Ch (Guard Time in milliseconds) and 100Dh (Life Time Factor) are used to implement the life guarding protocol. The Guard Time multiplied with the Life Time Factor gives the Life Time in milliseconds.
It is 0 (zero) if not used.

Index	100Dh
Name	Life Time Factor
Description	-
Data Type	Unsigned 16
Access modes	RW
PDO Mapping	No
Value Range	
Default Value	0

Index 100E : COB-ID Guard

Identifier of Can Object for the Node Guarding protocol.

Index	100Eh
Name	COB-ID Guard
Description	-
Data Type	Unsigned 32
Access modes	RW
PDO Mapping	No
Value Range	-
Default Value	700h + Node-ID

Index 1010 : Store Parameters

This object supports the saving of parameters in non-volatile memory. By read access the device provides information about its saving capabilities. Several parameter groups are distinguished:
Sub-Index 0 contains the largest Sub-Index that is supported.

Writing to Sub-Index 1 means that all parameters shall be stored on the device.

In order to avoid storage of parameters by mistake, storage is only executed when a specific signature is written to the appropriate Sub-Index. (This means that the signature is transferred as data bytes 4 to 7 in the CAN message of the corresponding SDO protocol.

The signature is "save".

MSB		LSB	
e	v	a	s
65h	76h	61h	73h

On reception of the correct signature on sub-index 1 the device stores the parameters and then confirms the SDO transmission (initiate download response). If the storing failed, the device responds with an Abort SDO Transfer (abort code: 0606 0000 h).
If a wrong signature is written, the device refuses to store and responds with Abort SDO Transfer (Abort code: 0800 002x h).

Index	1010h
Name	Store Parameters
Description	-
Data Type	Structure

Index	1010h Subindex 0
Name	Largest SubIndex supported
Description	-
Data Type	Unsigned char
Access modes	RO
PDO Mapping	No
Value Range	1
Default Value	1

Index	1010h Subindex 1
Name	Store All Parameters
Description	Writing to this object stores the dictionary to non-volatile memory.
Data Type	Unsigned 32
Access modes	RW
PDO Mapping	No
Value Range	Signature "save"
Default Value	-

By read access to object 1010h Subindex 1, the device responds with SDO data 00000001h indicating that storing of data is only done on command.

Note:

Writing to this objected is only allowed in pre-operational mode.

Index 1011 : Restore Default Parameters

With this object the default values of parameters according to the communication or device profile are restored. By read access the device provides information about its capabilities to restore these values. Several parameter groups are distinguished: Sub-Index 0 contains the largest Sub-Index that is supported.

Writing to Sub-Index 1 restores all parameters that can be restored.

In order to avoid the restoring of default parameters by mistake, restoring is only executed when a specific signature is written to the appropriate sub-index. (This means that the signature is transferred as data bytes 4 to 7 in the CAN message of the corresponding SDO protocol.

The signature is "load".

MSB		LSB	
d	a	o	l
64h	61h	6Fh	6Ch

On reception of the correct signature on sub-index 1 the device restores the parameters and then confirms the SDO transmission (initiate download response). If the storing failed, the device responds with an abort SDO transfer (abort code: 0606 0000h).

If a wrong signature is written, the device refuses to store and responds with Abort SDO Transfer (Abort code: 0800 002x h).

The default values are set valid after the device is reset (reset node) or power cycled. If the device requires storing on command (see Object 1010h), the appropriate command has to be executed after the reset if the default parameters are to be stored permanently.

Index	1011h
Name	Restore Default Parameters
Description	-
Data Type	Structure

Index	1011h Subindex 0
Name	Largest SubIndex supported
Description	-
Data Type	Unsigned char
Access modes	RO
PDO Mapping	No
Value Range	1
Default Value	1

Index	1011h Subindex 1
Name	Restore All Parameters
Description	Writing to this object restores the default values to the dictionary.
Data Type	Unsigned 32
Access modes	RW
PDO Mapping	No
Value Range	Signature "load"
Default Value	-

By read access to object 1011h Subindex 1, the device responds with SDO data 00000001h indicating that restoring of default data is available.

Note:

Writing to this objected is only allowed in pre-operational mode.

Index 1014 : COB-ID Emergency

Identifier of Can Object for the emergency messages.

Index	1014h
Name	COB-ID Emergency
Description	-
Data Type	Unsigned 32
Access modes	RW
PDO Mapping	No
Value Range	-
Default Value	80h + Node-ID

Index 1015 : Inhibit Time Emergency

Inhibit Time for emergency messages. If the Inhibit Time is set to 0, inhibit delay is disabled. The Inhibit Time is a multiple of 100usec, but the CO4011A offers a maximum resolution of 1 millisecond.

Index	1015h
Name	Inhibit Time Emergency
Description	-
Data Type	Unsigned 16
Access modes	RW
PDO Mapping	No
Value Range	-
Default Value	0

Index 1017 : Producer Heartbeat Time

The producer heartbeat time defines the cycle time of the heartbeat. The producer heartbeat time is 0 if it not used. The time has to be a multiple of 1ms.

Index	1017h
Name	Producer Heartbeat Time
Description	-
Data Type	Unsigned 16
Access modes	RW
PDO Mapping	No
Value Range	-
Default Value	0

Note:

Either Heartbeat or node guarding may be allowed at the same time. Do not use both protocols at the same time.

See additional brochure for further information about heartbeat protocol.

Index 1018 : Identity Object

The object at index 1018h contains general information about the device and the manufacturer frenzel + berg elektronik. It cannot be modified.

Index	1018h
Name	Identity Object
Description	-
Data Type	Structure

Index	1018h Subindex 0
Name	Largest SubIndex supported
Description	-
Data Type	Unsigned char
Access modes	RO
PDO Mapping	No
Value Range	-
Default Value	3

Index	1018h Subindex 1
Name	Vendor ID
Description	Registration Code of frenzel + berg elektronik at the CiA
Data Type	Unsigned 32
Access modes	RO
PDO Mapping	No
Value Range	-
Default Value	58h

Index	1018h Subindex 2
Name	Product Code
Description	Internal Product Code for CO4011A at frenzel + berg elektronik
Data Type	Unsigned 32
Access modes	RO
PDO Mapping	No
Value Range	-
Default Value	0104 0111 h

Index	1018h Subindex 3
Name	Revision Code
Description	
Data Type	Unsigned 32
Access modes	RO
PDO Mapping	No
Value Range	-
Default Value	Revision of the device

Index 2000 : Device Manufacturer

This Object shows "Frenzel + Berg" as visible string. If OEMs do not want to give access to this entry, it may be removed from the EDS (electronic data sheet).

Index	2000h
Name	Device Manufacturer
Description	-
Data Type	Visible String
Access modes	RO
PDO Mapping	No
Value Range	-
Default Value	"Frenzel + Berg"

Index 2100 : New Node ID

This Object is implemented to enable applications without any switches for setting the node ID. This object enables setting of the node ID by using SDO transfer.

Index	2100h
Name	New Node ID
Description	-
Data Type	Unsigned 8
Access modes	RW
PDO Mapping	No
Value Range	-
Default Value	0

If no node ID is selected with configuration input bits ID0 to ID6. The New Node ID object is enabled. See Index 100B for details in setting the node ID.

Index 2101 : System Configuration

This Object returns the operation mode of the CO4011A. It represents the inverted Setting of the configuration input bits CFG0 to CFG3.

Index	2101h
Name	System Configuration
Description	-
Data Type	Unsigned 32
Access modes	RO
PDO Mapping	No
Value Range	-
Default Value	Depends on CFG0 to CFG3

Index 2110 : Enable Boot Up Message

This Object enables or disables sending of the boot up message. The boot up message is CAN object with the identifier of the node guarding object and only one data byte with value 0 (zero). If object 2110h is set to 0 the boot up message is disabled otherwise it is enabled.

Index	2110h
Name	Enable Boot Up Message
Description	-
Data Type	Unsigned 8
Access modes	RW
PDO Mapping	No
Value Range	-
Default Value	1 (enabled)

Index 2180 : CAN Restart Time

This Object gives the restart time out for the CAN communication layer in case of bus off errors in milliseconds.

If the restart time is set to 0 automatic restart of the device in case of bus off is prohibited.

Index	2180h
Name	CAN Restart Time
Description	-
Data Type	Unsigned 16
Access modes	RW
PDO Mapping	No
Value Range	-
Default Value	0 (restart disabled)

DS301: PDO Parameter Objects

Communication Parameter Objects

The following table shows the communication parameter objects for Index 140x (Receive PDOs) and Index 180x (Transmit PDOs). The tables show Index 1400 as an example for all PDOs

The transmission type (sub-index 2) defines the mode for transmission / reception of the PDO. See table for detailed description of this entry.

Description of transmission type:

Type	PDO transmission				
	cyclic	acyclic	Sync related	Async.	Only on remote
0		X	X		
1-240	X		X		
241-251	Reserved				
252			X		X
253				X	X
254				X	
255				X	

Synchronous (transmission types 0-240 and 252) means that the transmission of the PDO shall be related to the SYNC object. Asynchronous means that the transmission of the PDO is not related to the SYNC object.

A transmission type of zero means that the message shall be transmitted synchronously with the SYNC object but not periodically but only in case of data change.

A value between 1 and 240 means that the PDO is transferred synchronously and cyclically, the transmission type indicating the number of SYNC signals, which are necessary to trigger PDO transmissions or receptions.

The transmission types 252 and 253 mean that the PDO is only transmitted on reception of a remote frame. At transmission type 252, the data is updated (but not sent) immediately after reception of the SYNC object. At transmission type 253 the data is updated at the reception of the remote frame. These values are only possible for transmit PDOs.

Transmission type 254 selects the CanEASY mode. Transmission type 255 means, the application event is defined in the device profile. For receive PDOs the reception of a PDO will update the mapped data (normally the analog or digital outputs).

Sub-index 3h contains the inhibit time. This time is a minimum interval for PDO transmission. The value is defined as multiple of 100ms.

Sub-index 4h is reserved.

In mode 254/255 additionally an event time can be used for TPDO. If an event timer exists for a TPDO (value not equal to 0) the elapsed timer is considered to be an event. The event time is a multiple of 1 ms. This event will cause the transmission of this TPDO in addition to otherwise defined events.

Index	1400h
Name	Receive PDO1 Communication Parameters
Description	-
Data Type	Structure

Index	1400h Subindex 0
Name	Largest SubIndex supported
Description	-
Data Type	Unsigned 8
Access modes	RO
PDO Mapping	No
Value Range	-
Default Value	5

Index	1400h Subindex 1
Name	COB-ID
Description	Identifier for CAN-Object for PDO1
Data Type	Unsigned 32
Access modes	RW
PDO Mapping	No
Value Range	-
Default Value	200h + Node-Id

Index	1400h Subindex 2
Name	Transmission Type
Description	-
Data Type	Unsigned 8
Access modes	RW
PDO Mapping	No
Value Range	-
Default Value	0FFh

Index	1400h Subindex 3
Name	Inhibit Time
Description	-
Data Type	Unsigned 16
Access modes	RW
PDO Mapping	No
Value Range	-
Default Value	0

Index	1400h Subindex 4
Name	Reserved
Description	-
Data Type	-
Access modes	-
PDO Mapping	No
Value Range	-
Default Value	-

Index	1400h Subindex 5
Name	Event Time
Description	-
Data Type	Unsigned 16
Access modes	RW
PDO Mapping	No
Value Range	-
Default Value	0

The PDO communication parameter objects have the same structure for all PDOs. The following Objects are used.

Index	PDO
1400h	Receive PDO1 (digital output)
1401h	Receive PDO2 (analog output) Not implemented in CO4011A
1800h	Transmit PDO1 (digital input)
1801h	Transmit PDO2 (analog input)

PDO Mapping Objects

The following table shows the PDO Mapping Objects. The principle of PDO mapping is the same for all PDOs. The PDO Mapping table is the cross reference between the Object dictionary entries (for example the data of an digital output byte) and the data field inside an PDO data field (position in the data field of a CAN message for PDO transfer).

Subindex 0 determines the valid number of objects that have been mapped. The CO4011 allows a maximum of 8 mapped objects for each PDO. For changing the PDO mapping first subindex 0 must be set to 0 (mapping is deactivated). Then the objects can be remapped. When a new object is mapped by writing a subindex between 1 and 8, the device may check whether the object specified by index /subindex exists. If the object does not exist or the object cannot be mapped, the SDO transfer will be aborted.

If the special CAN features are enabled (CFG3=0), the CO4011 allows adding of additional mapping entries without resetting subindex 0. In this case the device calculates the number of mapped objects by itself and modifies subindex 0 respectively.

Subindexes 1 to 8 keep the pointers of the mapped objects as unsigned 32 values. The value is 0 if there is no mapped object. The structure for these pointers is as follows.

MSB		LSB	
Byte3	Byte2	Byte1	Byte0
Mapped index		Subindex	Length

Mapped Index and Subindex together are the Pointer to the Object dictionary data to be mapped at this location. Length gives the length of the mapped object in bits.

The following mapping object uses index 1600 as an example for all mapping objects.

Index	1600h
Name	Receive PDO1 Mapping Parameters
Description	-
Data Type	Array

Index	1600h Subindex 0
Name	Largest SubIndex supported
Description	Number of mapped objects
Data Type	Unsigned 8
Access modes	RW
PDO Mapping	No
Value Range	-
Default Value	According to operation mode

Index	1600h Subindex 1 to 8
Name	Mapped object
Description	
Data Type	Unsigned 32
Access modes	RW
PDO Mapping	No
Value Range	-
Default Value	According to operation mode

Example:

As an example for PDO mapping, the following table shows the default mapping for transmit PDO1 in operation mode 0 (20 digital in/12 digital out).

Index	Entry	Explanation
1A00.00	3	There are 3 mapped objects in transmit PDO1
1A00.01	60000108h	First mapped object: Input Byte0
1A00.02	60000208h	First mapped object: Input Byte1
1A00.03	60000308h	First mapped object: Input Byte2

The data of the transmit PDO1 for this example will be three bytes. (Input Bytes 0 to 3)

The PDO mapping objects have the same structure for all PDOs. The following Objects are used.

Index	PDO
1600h	Receive PDO1 (digital output)
1601h	Receive PDO2 (analog output) Not implemented in CO4011A
1A00h	Transmit PDO1 (digital input)
1A01h	Transmit PDO2 (analog input)

All objects with PDO mapping capabilities (not only digital or analog I/O) may be mapped to one of the PDOs.

DS401: Digital Input Objects

The following objects are describing the functionality of the digital input lines of the CO4011A

Index 5001/2 : Write to Digital Input

The object 5001 and 5002 are implemented for debug purposes, because the CANopen object 6000 does not allow write access to an input line. With objects 5001 and 5002 a debug environment may simulate setting or resetting of input lines. The CO4011 first scans the physical input lines and then processes the scanned values with the debug parameters.

Index 5001 and 5002 make direct bit manipulation of single bits possible.

Index 5001 enables bit setting by using a bit wise logical OR conjunction with index 6000 while index 5002 performs a logical AND conjunction with index 6000 and therefore enables resetting of single bits.

Objects 5001 and 5002 are always working in continuous execution mode. This means that logical operations with object 6000 are performed in each internal input scan cycle

Index	5001h (5002h)
Name	Write 1 to digital input (Write 0 to digital input)
Description	-
Data Type	Array

Index	Subindex 0
Name	
Description	Number of mapped objects
Data Type	Unsigned 8
Access modes	RO
PDO Mapping	NO
Value Range	-
Default Value	Number of digital input bytes

Index	Subindex 1 to Nr of input bytes
Name	
Description	Bitmap to mask input byte with
Data Type	Unsigned 8
Access modes	RW
PDO Mapping	YES
Value Range	-
Default Value	0 for 5001 (0FFh for 5002)

Index 5003 : Filter Time Digital Input

The CO4011A offers noise filtering for each digital input line. With object 5003 an individual filter time may be assigned to each input line.

The filtering function enable object is at index 6003h. The filter time is set in milliseconds. A value of 0 disables the filtering function.

Index	5003h
Name	Filter Time Digital Input
Description	-
Data Type	Array

Index	Subindex 0
Name	Nr of Subobjects
Description	
Data Type	Unsigned 8
Access modes	RO
PDO Mapping	No
Value Range	-
Default Value	Number of digital input lines

Index	Subindex 1 to Nr of input lines
Name	Filter Time
Description	There is a individual Time for each input line.
Data Type	Unsigned 8
Access modes	RW
PDO Mapping	No
Value Range	-
Default Value	5

Index 6000 : Read Digital Input 8 Bit

This object represents the digital input bytes. The value of the input lines is written to this object.

Before writing the level of the input lines to object 6000, the input data is processed in the following way:

- 1) The digital input lines are active low. This means, the input level is inverted at first.
- 2) At the next stage, the CO4011A processes the filtering function. Object 5003 gives the filtering time and object 6003 enables or disables the channels.
- 3) Then the input lines are inverted again according to the setting of object 6002h (polarity input)
- 4) At last the debug function calculates a logical OR conjunction between the input lines and object 5001 and a logical AND with object 5002 and then writes the result to object 6000h

The number of digital input bytes depends on the selected operation mode.

The mapping of the I/O lines to object 6000 is explained in chapter "Mapping I/O to Object Dictionary"

Index	6000h
Name	Digital Input 8 Bit
Description	-
Data Type	Array

Index	Subindex 0
Name	Nr of Subobjects
Description	
Data Type	Unsigned 8
Access modes	RO
PDO Mapping	No
Value Range	-
Default Value	Number of digital input bytes

Index	Subindex 1 to Nr of input bytes
Name	Digital Input 8 Bit Byte n
Description	
Data Type	Unsigned 8
Access modes	RO
PDO Mapping	Yes
Value Range	-
Default Value	-

Index 6100 : Read Digital Input 16 Bit

This object enables 16-Bit access to the digital input bytes. The Object addresses the same data area as object 6000 but using unsigned integer data type. See Index 6000 for further details.

Index 6120 : Read Digital Input 32 Bit

This object enables 32-Bit access to the digital input bytes. The Object addresses the same data area as object 6000 but using unsigned long data type. See Index 6000 for further details.

Index 6002 : Polarity Input 8 Bit

With this object, the digital inputs may be inverted. See also Index 6000 for additional information. The number of digital input bytes depends on the selected operation mode.

Index	6002h
Name	Polarity Input 8 Bit
Description	-
Data Type	Array

Index	Subindex 0
Name	Nr of Subobjects
Description	
Data Type	Unsigned 8
Access modes	RO
PDO Mapping	No
Value Range	-
Default Value	Number of digital input bytes

Index	Subindex 1 to Nr of input bytes
Name	Polarity Input 8 Bit Byte n
Description	
Data Type	Unsigned 8
Access modes	RW
PDO Mapping	No
Value Range	-
Default Value	0

Index 6003 : Filter Enable Input 8 Bit

With this object, the additional input filtering may be enabled individual for each input. 0 at the input line corresponding bit position means filter is disabled. See also Index 5003.

The number of digital input bytes depends on the selected operation mode.

Index	6002h
Name	Polarity Input 8 Bit
Description	-
Data Type	Array

Index	Subindex 0
Name	Nr of Subobjects
Description	
Data Type	Unsigned 8
Access modes	RO
PDO Mapping	No
Value Range	-
Default Value	Number of digital input bytes

Index	Subindex 1 to Nr of input bytes
Name	Polarity Input 8 Bit Byte n
Description	
Data Type	Unsigned 8
Access modes	RW
PDO Mapping	No
Value Range	-
Default Value	0

Index 6005 : Global Interrupt Enable

This object enables or disables globally the interrupt behaviour without changing the interrupt masks.

In event-driven mode the device transmits the input values depending on the interrupt masks in objects 6006h, 6007h, and 6008h and the PDO transmission type.

TRUE (1)= global interrupt enabled
FALSE (0)= global interrupt disabled

Index	6005h
Name	Global Interrupt Enable
Description	-
Data Type	Boolean
Access modes	RW
PDO Mapping	No
Value Range	-
Default Value	TRUE

Index 6006 : Interrupt Mask Any Change

This object determines, which input lines shall activate an interrupt by any change of the input line. Both negative and positive edge will cause an interrupt, if enabled.

An interrupt will cause a PDO transmission in case of event driven transmission mode.

1 = interrupt enabled

0 = interrupt disabled

Index	6006h
Name	Interrupt Mask any change
Description	-
Data Type	Array

Index	Subindex 0
Name	Nr of Subobjects
Description	
Data Type	Unsigned 8
Access modes	RO
PDO Mapping	No
Value Range	-
Default Value	Number of digital input bytes

Index	Subindex 1 to Nr of input bytes
Name	Interrupt Mask any change
Description	
Data Type	Unsigned 8
Access modes	RW
PDO Mapping	No
Value Range	-
Default Value	0FFh (interrupt enabled)

Index 6007 : Interrupt Mask Low to High

This object has the same structure and behaviour as object 6006h but will cause interrupts only on rising edge of object index 6000. Note that input lines are active low, so rising edge of input data (object 6000) means falling edge of input port line.

Default value is 0.

Index 6008 : Interrupt Mask High to Low

This object has the same structure and behaviour as object 6006h but will cause interrupts only on falling edge of object index 6000. Note that input lines are active low, so falling edge of input data (object 6000) means rising edge of input port line.

Default value is 0.

DS401: Digital Output Objects

The following objects are describing the functionality of the digital output lines of the CO4011A. The CO4011A supports only 8bit access.

The number of digital output bytes depends on the selected operation mode.

Index 5200 : Output Reset on Error Option

This Object selects the function for error handling if a critical error is detected.

If the value is 0, the Outputs objects 6200.xx will keep unchanged. The ports will be set to their error state given in object 6207 as long as the error is active. If error ends, the outputs will return to the state according to the output object 6200h.

If the value is 1, the Outputs error handling depends on the objects 6206h and 6207h and the output object 6200 will be overwritten with the error output state according to objects 6206 and 6207.

Index	5200h
Name	Output Reset on Error Option
Description	-
Data Type	Unsigned 8
Access modes	RW
PDO Mapping	No
Value Range	-
Default Value	1

Index 6200 : Write to Digital Output

With object 6200, the digital outputs of the CO4011A can be written to. Before writing to the output ports, the value of the bitmap of object 6200 is processed with object 6202 (Change polarity output 8 bit) and the inverted. (Output port bits of the CO4011A device are active low)

The mapping of the I/O lines to object 6200 is explained in chapter "Mapping I/O to Object Dictionary"

Index	6200h
Name	Write to digital output
Description	-
Data Type	Array

Index	Subindex 0
Name	
Description	Number of mapped objects
Data Type	Unsigned 8
Access modes	RO
PDO Mapping	NO
Value Range	-
Default Value	Number of digital output bytes

Index	Subindex 1 to Nr of output bytes
Name	Write to digital output
Description	
Data Type	Unsigned 8
Access modes	RW
PDO Mapping	YES
Value Range	-
Default Value	0

Index 6300 : Write Digital Output 16 Bit

This object enables 16-Bit access to the digital output bytes. The Object addresses the same data area as object 6200 but using unsigned integer data type. See Index 6200 for further details.

Index 6320 : Write Digital Output 32 Bit

This object enables 32-Bit access to the digital output bytes. The Object addresses the same data area as object 6200 but using unsigned long data type. See Index 6200 for further details.

Index 6202 : Polarity Output 8 Bit

With this object, the digital outputs may be inverted. See also Index 6200 for additional information.

Index	6202h
Name	Polarity Output 8 Bit
Description	-
Data Type	Array

Index	Subindex 0
Name	Nr of Subobjects
Description	
Data Type	Unsigned 8
Access modes	RO
PDO Mapping	No
Value Range	-
Default Value	Number of digital output bytes

Index	Subindex 1 to Nr of input bytes
Name	Polarity Output 8 Bit Byte n
Description	
Data Type	Unsigned 8
Access modes	RW
PDO Mapping	No
Value Range	-
Default Value	0

Index 6206 : Error Mode Output 8 Bit

This object indicates, whether an output is forced to a predefined value (given in object 6207) in case of a device error.

- 1 = Output will be forced to the value selected in object 6207
- 0 = Output will be unchanged even in case of an error condition.

Index	6206h
Name	Error Mode Output 8 Bit
Description	-
Data Type	Array

Index	Subindex 0
Name	Nr of Subobjects
Description	
Data Type	Unsigned 8
Access modes	RO
PDO Mapping	No
Value Range	-
Default Value	Number of digital output bytes

Index	Subindex 1 to Nr of input bytes
Name	Error Mode Output 8 Bit Byte n
Description	
Data Type	Unsigned 8
Access modes	RW
PDO Mapping	No
Value Range	-
Default Value	0FFh (Take error condition from object 6207)

Index 6207 : Error Value Output 8 Bit

This object selects the level the outputs are forced to in case of device error mode if the error mode (object 6206 is enabled)

1 = Output will be forced to active state

0 = Output will be forced to inactive state.

Note: Outputs of CO4011 are active low.

Index	6207h
Name	Error Value Output 8 Bit
Description	-
Data Type	Array

Index	Subindex 0
Name	Nr of Subobjects
Description	
Data Type	Unsigned 8
Access modes	RO
PDO Mapping	No
Value Range	-
Default Value	Number of digital output bytes

Index	Subindex 1 to Nr of input bytes
Name	Error Value Output 8 Bit Byte n
Description	
Data Type	Unsigned 8
Access modes	RW
PDO Mapping	No
Value Range	-
Default Value	0 (Inactive, high level)

DS401: Analog Input Objects

The following objects are describing the functionality of the analog input lines of the CO4011A.

The number of analog input bytes depends on the selected operation mode.

Index 6400 : Read Analog Input 8 Bit

Object 6400, represents the value of the analog channels. The 8 bit conversion result of the analog input voltage is a signed value. Therefore voltages less than 2.5V are read as negative input voltage. An input of 2.5V is read as 0 and an input voltage higher than 2.5V is converted into positive values.

If the application requires reading of the analog input voltage as unsigned values, the object 6431 may be used for adding an offset to the conversion result.

The mapping of the I/O lines to object 6400 is explained in chapter "Mapping I/O to Object Dictionary"

Note:

Object 6400 is only valid if operation mode selects 8 Bit resolution of A/D converter.

Index	6400h
Name	Read Analog Input
Description	-
Data Type	Array

Index	Subindex 0
Name	
Description	Number of mapped objects
Data Type	Unsigned 8
Access modes	RO
PDO Mapping	NO
Value Range	-
Default Value	Number of analog input bytes

Index	Subindex 1 to Nr of input lines
Name	Read Analog Input
Description	
Data Type	Signed 8
Access modes	RO
PDO Mapping	YES
Value Range	-
Default Value	-

Index 6401 : Read Analog Input 16 Bit

Object 6401, represents the value of the analog channels. The 16 bit conversion result of the analog input voltage is a signed value. Therefore voltages less than 2.5V are read as negative input voltage. An input of 2.5V is read as 0 and an input voltage higher than 2.5V is converted into positive values.

If the application requires reading of the analog input voltage as unsigned values, the object 6431 may be used for adding an offset to the conversion result.

The mapping of the I/O lines to object 6401 is explained in chapter "Mapping I/O to Object Dictionary"

Note:

Object 6401 is only valid if operation mode selects 16 Bit resolution of A/D converter.

Index	6401h
Name	Read Analog Input
Description	-
Data Type	Array

Index	Subindex 0
Name	
Description	Number of mapped objects
Data Type	Unsigned 8
Access modes	RO
PDO Mapping	NO
Value Range	-
Default Value	Number of analog input bytes

Index	Subindex 1 to Nr of input lines
Name	Read Analog Input
Description	
Data Type	Signed 16
Access modes	RO
PDO Mapping	YES
Value Range	-
Default Value	-

Index 6421 : Analog Input Interrupt Trigger

Object 6421 selects the event that shall cause a transmission interrupt for the selected analog channel.

There is one Subindex for each channel to enable individual setting according to application requirements.

Table of possible Trigger Conditions:

Bit Nr	Interrupt Trigger Selection
0	Input voltage greater than Upper Limit
1	Input voltage less than Lower Limit
2	Input changed by more than Delta
3	Input reduced more than Negative Delta
4	Input increased more than Positive Delta
5 to 7	Reserved (must be forced to zero)

Index	6421h
Name	Analog Input Interrupt Trigger
Description	-
Data Type	Array

Index	Subindex 0
Name	
Description	Number of mapped objects
Data Type	Unsigned 8
Access modes	RO
PDO Mapping	NO
Value Range	-
Default Value	Number of analog input lines

Index	Subindex 1 to Nr of input lines
Name	Analog Input Interrupt Trigger
Description	Selects trigger condition
Data Type	Unsigned 8 (See Table of Trigger Conditions)
Access modes	RW
PDO Mapping	No
Value Range	-
Default Value	7

Index 6423 : Analog Input Interrupt Enable

This object enables or disables globally the interrupt behaviour without changing the interrupt masks. The interrupt is disabled by default, in order to avoid transmission of analog input values.

TRUE (1)= global interrupt enabled
FALSE (0)= global interrupt disabled

Index	6423h
Name	Analog Input Interrupt Enable
Description	-
Data Type	Boolean
Access modes	RW
PDO Mapping	No
Value Range	-
Default Value	FALSE

Index 6424/5/6/7/8 : Analog Input Interrupt Limits

These objects give the Limit for generation of interrupts. All objects have the same structure. The function of the interrupt limit is only enabled, if the corresponding bit of object 6421 is set. All values of limit parameters are signed 32. So the user must take care not to exceed the range of the input data objects.

Table of Limit Function

Object	Object Name and Function
6424	Analog Input Upper Limit Generate interrupt if input voltage is greater than Upper Limit (6424)
6425	Analog Input Lower Limit Generate interrupt if input voltage is less than Lower Limit (6425)
6426	Analog Input Interrupt Delta Generate interrupt if input voltage changed by more than Interrupt Delta
6427	Analog Input Negative Delta Generate interrupt if input voltage reduced by more than Negative Delta
6428	Analog Input Positive Delta Generate interrupt if input voltage increased by more than Positive Delta

Index	6424/5/6/7/8/9
Name	See table above
Description	-
Data Type	Array

Index	Subindex 0
Name	
Description	Number of mapped objects
Data Type	Unsigned 8
Access modes	RO
PDO Mapping	NO
Value Range	-
Default Value	Number of analog input lines

Index	Subindex 1 to Nr of input lines
Name	See table above
Description	
Data Type	Integer 32
Access modes	RW
PDO Mapping	No
Value Range	-
Default Value	0

Index 6431 : Analog Input Offset

Object 6431 adds an offset value to the analog input data object (6400 / 6401).

The normal input scaling for analog data objects 6400 and 6401 considers conversion of negative input voltages (input amplifier must shift to positive voltages because input port pin is 0 to 5V only) by placing the zero point (of data) to 2.5V. (middle of input voltage range)

If application requires only positive input values an offset may be add with object 6431, in order to adjust the zero point for data to an input voltage of 0V. For 8 Bit analog conversion (object 6400) the offset value (object 6431) must be 80h. For 16 Bit analog conversion (object 6401) the offset value must be set to 8000h.

Index	6431h
Name	Analog Input Offset
Description	-
Data Type	Array

Index	Subindex 0
Name	
Description	Number of mapped objects
Data Type	Unsigned 8
Access modes	RO
PDO Mapping	NO
Value Range	-
Default Value	Number of analog input lines

Index	Subindex 1 to Nr of input lines
Name	Analog Input Offset
Description	
Data Type	Signed 32
Access modes	RW
PDO Mapping	No
Value Range	-
Default Value	0

Power Down Control Objects

For control of the Power-Down-Mode several objects are applied in the object dictionary of the CO4011.

Index 2FF9 : Power Down with Stop Node

This object enables switching the device to power down state by using the NMT command stop node. This feature is enabled by writing the value 0x454E534E ("ENSN") to this object and additionally object 2FFE ("Enable Power Down") must be set with the valid signature. As soon as this two signatures are set, the Stop Node Command will switch the Chip to Power down mode.

Index	2FFD
Name	Reset Power Down Input Enable
Description	-
Data Type	Unsigned 32
Access modes	RW
PDO Mapping	NO
Value Range	-
Default Value	0

Note:

Using the NMT command STOP NODE for power down control is not compatible with the CANopen draft standard.

Index 2FFA : Wake-Up-Confirm-Time

Wake-Up-Confirm-Time

The CO4011 switches to the active run mode after a wake up event by pin WUII (Wake-Up-Interrupt-Input).

If it doesn't receive a valid NMT telegram during the Wake-Up-Confirm-Time, so it automatically switches back to the Power-Down-Mode.

The time is given in milliseconds.

The access is done by SDO.

Index	2FFA
Name	Wake-Up-Confirm-Time
Description	-
Data Type	Unsigned 16
Access modes	RW
PDO Mapping	NO
Value Range	200 .. 20000
Default Value	1000

Index 2FFB : Power-Down-Delay-Time

Power-Down-Delay-Time

After reception of Power-Down instruction the CO4011 waits for the period Power-Down Delay Time and then switches over in Power-Down-Mode. The time is given in milliseconds. The access is done by SDO.

Index	2FFB
Name	Power-Down-Delay-Time
Description	-
Data Type	Unsigned 16
Access modes	RW
PDO Mapping	NO
Value Range	0 .. 20000
Default Value	500

Index 2FFC : Wake-Up-Counter

Wake-Up-Counter

The Wake Up Counter counts all wake up events of Power-Down-Mode. The access to the counter is done by SDO.

Index	2FFC
Name	Wake-Up-Counter
Description	-
Data Type	Unsigned 32
Access modes	RW
PDO Mapping	YES
Value Range	-
Default Value	0

Index 2FFD : Reset Power Down Input Pin Enable

Enable "Reset Power Down Input"

Reset Power Down Input is configured by writing the value 0x5250454E ("RPEN") to this object. As soon as this signature will be written pin1 (IN9) is used as Reset Power Down Input (RPDI). Then it cannot be used as digital input line any more.

Index	2FFD
Name	Reset Power Down Input Enable
Description	-
Data Type	Unsigned 32
Access modes	RW
PDO Mapping	NO
Value Range	-
Default Value	0

Index 2FFE : Power-Down-Enable

Power-Down-Enable

The use of Power-Down-Mode is enabled by writing the value 0x5044454E ("PDEN") to this object. As soon as this signature will be written, pin2 (IN8) is configured as Wake-Up-Interrupt-Input (WUII). Then it cannot be used as digital input pin any more. The correct signature is the requirement for acceptance of all further power down instructions.

Index	2FFE
Name	Power-Down-Enable
Description	-
Data Type	Unsigned 32
Access modes	RW
PDO Mapping	NO
Value Range	-
Default Value	0

Index 2FFF : Switch-To-Power-Down-Mode

Switch-To-Power-Down-Mode

Setting the value 0x504F4646 ("POFF") (see above) will force the device to power down mode. After receiving the Switch-To-Power-Down-Mode command, the chip will continue working for the Power-Down-Delay-Time and then will enter power down mode.

The correct signature in object 2FFE is the requirement for acceptance of the Switch-To-Power-Down-Mode instruction.

Index	2FFF
Name	Switch To Power Down Mode
Description	-
Data Type	Unsigned 32
Access modes	WO
PDO Mapping	NO
Value Range	-
Default Value	0

Mapping I/O to Object Dictionary

The mapping of the I/O channels depends on the setting of configuration bits CFG0 to CFG2.

All possible configurations are shown in individual tables. Select the table for your application according to I/O requirements.

Note for A/D converter the maximum resolution is 10 bit. Tables that show analog input with 16-bit mean, that dictionary entry is made as signed integer (16 bit wide).

Summary of operation modes

The following table shows a summary of possible operation modes.

CFG				Mode	Description
3	2	1	0		
1	1	1	1	0	20 digital In / 12 dig. Out
1	1	1	0	1 *2)	12 dig. In / 12 dig. Out. 8 analog In 8 bit
1	1	0	1	2	16 dig. In / 12 dig. Out. 4 analog In 16 bit
1	1	0	0	3	reserved *1)
1	0	1	1	4	12 digital In / 20 dig. Out
1	0	1	0	5 *2)	4 dig. In / 20 dig. Out. 8 analog In 8 bit
1	0	0	1	6	8 dig. In / 20 dig. Out. 4 analog In 16 bit
1	0	0	0	7	reserved *1)
0	x	x	X		reserved *1)

*1) These modes are reserved for future use and must not be set. Selecting the reserved modes may cause improper operation of the device.

*2) This modes have default PDO mapping which is not according to CiA standard DS401.

The selected operation mode may be read via object 2101h from the object dictionary.

Note:

Setting of configuration must be fixed. The CO4011 scans the setting of CFG0 to CFG3 only during reset. Changing of configuration on the fly is not allowed and may cause improper operation of the device.

Note that configuration pins are input during reset but may be switched to output during operation. See Pin Description for additional information.

20 digital in / 12 digital out

Operation mode 0								
CFG 2 = 1 CFG1 = 1 CFG0 = 1								
EDS-file: CO4011A0.EDS								
Data Mapping to Dictionary								
Index. SubIndex	Mapped I/O Signal bit/value							
	7	6	5	4	3	2	1	0
6000.01	IN7 to IN0							
6000.02	IO3 to IO0				IN11 to IN8			
6000.03	-	-	-	-	IO7 to IO4			
6200.01	OUT7 to OUT0							
6200.02	-	-	-	-	OUT11 to 8			
6401.01	Conversion result IN0 (16 bit)							
6401.02	Conversion result IN1 (16 bit)							
6401.03	Conversion result IN2 (16 bit)							
6401.04	Conversion result IN3 (16 bit)							
Default PDO Mapping								
PDO	Mapped Data							
RPDO1	6200.01 digital output OUT0 to 7 6200.02 digital output OUT8 to 11							
TPDO1	6000.01 digital input IN0 to IN7 6000.02 digital input IN8 to IN11 6000.03 digital input IO0 to IO7							

I/O Port is used for digital Input.

16 dig. in / 12 dig. out / 4 analog in 16 bit

Operation mode 2								
CFG 2 = 1 CFG1 = 0 CFG0 = 1								
EDS-file: CO4011A2.EDS								
Data Mapping to Dictionary								
Index. SubIndex	Mapped I/O Signal bit/value							
	7	6	5	4	3	2	1	0
6000.01	IN11 to IN8				IN7 to IN4			
6000.02	IO7 to IO0 used as digital inputs							
6200.01	OUT7 to OUT0							
6200.02	-	-	-	-	OUT11 to 8			
6401.01	Conversion result IN0 (16 bit)							
6401.02	Conversion result IN1 (16 bit)							
6401.03	Conversion result IN2 (16 bit)							
6401.04	Conversion result IN3 (16 bit)							
Default PDO Mapping								
PDO	Mapped Data							
RPDO1	6200.01 digital output OUT0 to 7 6200.02 digital output OUT8 to 11							
TPDO1	6000.01 digital input IN4 to IN11 6000.02 digital input IO0 to IO7							
TPDO2	6401.01 analog input IN0 (16 bit) 6401.02 analog input IN1 (16 bit) 6401.03 analog input IN2 (16 bit) 6401.04 analog input IN3 (16 bit)							

12 digital in / 20 digital out

Operation mode 4								
CFG 2 = 0 CFG1 = 1 CFG0 = 1								
EDS-file: CO4011A4.EDS								
Data Mapping to Dictionary								
Index. SubIndex	Mapped I/O Signal bit/value							
	7	6	5	4	3	2	1	0
6000.01	IN7 to IN0							
6000.02	-	-	-	-	IN11 to IN8			
6200.01	OUT7 to OUT0							
6200.02	IO3 to IO0				OUT11 to 8			
6200.03	-	-	-	-	IO7 to IO4			
6401.01	Conversion result IN0 (16 bit)							
6401.02	Conversion result IN1 (16 bit)							
6401.03	Conversion result IN2 (16 bit)							
6401.04	Conversion result IN3 (16 bit)							
Default PDO Mapping								
PDO	Mapped Data							
RPDO1	6200.01 digital output OUT0 to 7 6200.02 digital output OUT8 to 11 6200.03 digital output IO0 to IO7							
TPDO1	6000.01 digital input IN0 to IN7 6000.02 digital input IN8 to IN11							

8 dig. in / 20 dig. out / 4 analog in 16 bit

Operation mode 6								
CFG 2 = 0 CFG1 = 0 CFG0 = 1								
EDS-file: CO4011A6.EDS								
Data Mapping to Dictionary								
Index. SubIndex	Mapped I/O Signal bit/value							
	7	6	5	4	3	2	1	0
6000.01	IN11 to IN8				IN7 to IN4			
6200.01	OUT7 to OUT0							
6200.02	IO3 to IO0				OUT11 to 8			
6200.03	-	-	-	-	IO7 to IO4			
6401.01	Conversion result IN0 (16 bit)							
6401.02	Conversion result IN1 (16 bit)							
6401.03	Conversion result IN2 (16 bit)							
6401.04	Conversion result IN3 (16 bit)							
Default PDO Mapping								
PDO	Mapped Data							
RPDO1	6200.01 digital output OUT0 to 7 6200.02 digital output OUT8 to 11 6200.03 digital output IO0 to IO7							
TPDO1	6000.01 digital inputs IN4 to IN11							
TPDO2	6401.01 analog input IN0 (16 bit) 6401.02 analog input IN1 (16 bit) 6401.03 analog input IN2 (16 bit) 6401.04 analog input IN3 (16 bit)							

12 dig. in / 12 dig. out / 8 analog in 8 bit

Operation mode 1								
CFG 2 = 1 CFG1 = 1 CFG0 = 0								
EDS-file: CO4011A1.EDS								
Data Mapping to Dictionary								
Index. SubIndex	Mapped I/O Signal bit/value							
	7	6	5	4	3	2	1	0
6000.01	IO3 to IO0				IN11 to IN8			
6000.02	-	-	-	-	IO7 to IO4			
6200.01	OUT7 to OUT0							
6200.02	-	-	-	-	OUT11 to 8			
6400.01	Conversion result IN0 (8 bit)							
...							
6400.08	Conversion result IN7 (8 bit)							
Default PDO Mapping								
PDO	Mapped Data							
RPDO1	6200.01 digital output OUT0 to 7 6200.02 digital output OUT8 to 11							
TPDO1	6000.01 digital inputs IN8 to IN11 6000.02 digital input IO0 to IO7							
TPDO2	6400.01 analog input IN0 (8 bit) 6400.02 analog input IN1 (8 bit) 6400.08 analog input IN7 (8 bit)							

4 dig. in / 20 dig. out / 8 analog in 8 bit

Operation mode 5								
CFG 2 = 0 CFG1 = 1 CFG0 = 0								
EDS-file: CO4011A5.EDS								
Data Mapping to Dictionary								
Index. SubIndex	Mapped I/O Signal bit/value							
	7	6	5	4	3	2	1	0
6000.01	-	-	-	-	IN11 to IN8			
6200.01	OUT7 to OUT0							
6200.02	IO3 to IO0				OUT11 to 8			
6200.03	-	-	-	-	IO7 to IO4			
6400.01	Conversion result IN0 (8 bit)							
....							
6400.08	Conversion result IN7 (8 bit)							
Default PDO Mapping								
PDO	Mapped Data							
RPDO1	6200.01 digital output OUT0 to 7 6200.02 digital output byte 1 6200.03 digital output byte 2							
TPDO1	6000.01 digital inputs IN8 to IN11							
TPDO2	6400.01 analog input IN0 (8 bit) 6400.02 analog input IN1 (8 bit) 6400.08 analog input IN7 (8 bit)							

Absolute Maximum Ratings

Stresses greater than those listed parameters may cause permanent damage to the device. Functional operation should be restricted to recommended operation conditions. Exposure to absolute maximum rating conditions for extended times may affect reliability.

Parameter	Symbol	Rated Value		Units	Remarks
		Min.	Max.		
Power supply voltage	VCC	VSS – 0.3	VSS + 6.0	V	
Analog power supply voltage	AVCC	VSS – 0.3	VCC	V	
Analog reference voltage	AVREF	VSS – 0.3	VCC	V	
Input voltage	Vi	VSS – 0.3	VSS + 6.0	V	Vi < VCC + 0.3V
Output voltage	Vo	VSS – 0.3	VSS + 6.0	V	Vo < VCC + 0.3V
L level maximum output current	IOLMAX		15	mA	Time < 20 msec
L level maximum output current	IOL		4	mA	
H level maximum output current	IOHMAX		15	mA	Time < 20 msec
H level maximum output current	IOH		4	mA	
Maximum Power dissipation	P _{MAX}		300	mW	
Operating temperature	T _A	-40	+85	°C	CO4011A
	T _A	-40	+105	°C	CO4011AE
Storing temperature	T _A	-55	+150	°C	

Recommended Operation Conditions and Characteristics

Functional operation should be restricted to recommended operation conditions.

Parameter	Symbol	Rated Value			Units	Remarks
		Min.	Typ.	Max.		
Power supply voltage	VCC	4.5	5.0	5.5	V	
Analog power supply voltage	AVCC		VCC	VCC	V	
Analog reference voltage	AVREF	3.0		VCC	V	
Power supply current	I _{CC}		35	50	mA	All inputs V _{IL} or V _{IH} All outputs open
Input H voltage	V _{IH}	0.8 * VCC		VCC + 0.3	V	
Input L voltage	V _{IL}	VSS – 0.3		0.2 * VCC	V	
Output H voltage	V _{OH}	VCC – 0.5			V	I _{OH} = -4.0 mA
Output L voltage	V _{OL}			0.4	V	I _{OL} = 4.0 mA
Input leakage current	I _{LKC}	-5		5	uA	
Crystal frequency	f _{osc}		4		MHz	
Reset pulse width	t _{res}	10			us	
Power on rise time	t _{RESLH}	0.05		30	ms	
Maximum CANopen Delay input pin to bus telegram	t _{DITB}	0.05	0.5	2	ms	No additional bus distribution delay
Maximum CANopen Delay bus telegram to output pin	t _{DBTO}	0.05	0.5	2	ms	
Watchdog trigger frequency	f _{WDT}	100	1000	2000	Hz	Delayed max. 500 ms after reset
Maximum Power dissipation	P _{MAX}			300	mW	
Operating temperature	T _A	-40		+85	°C	CO4011A
	T _A	-40		+105	°C	CO4011AE

Package Dimension CO4011A

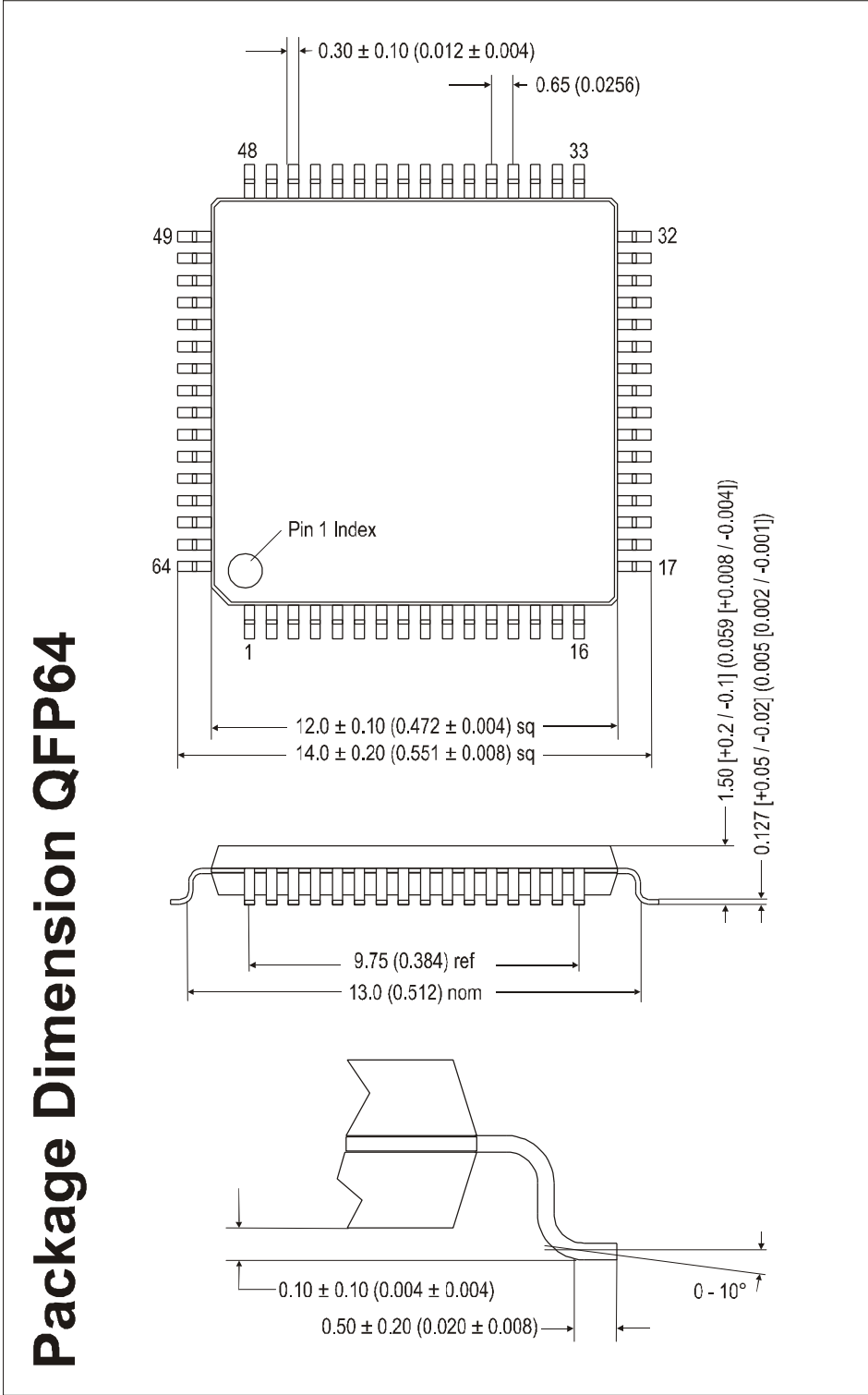

Typical Application: EVA board for CO4011

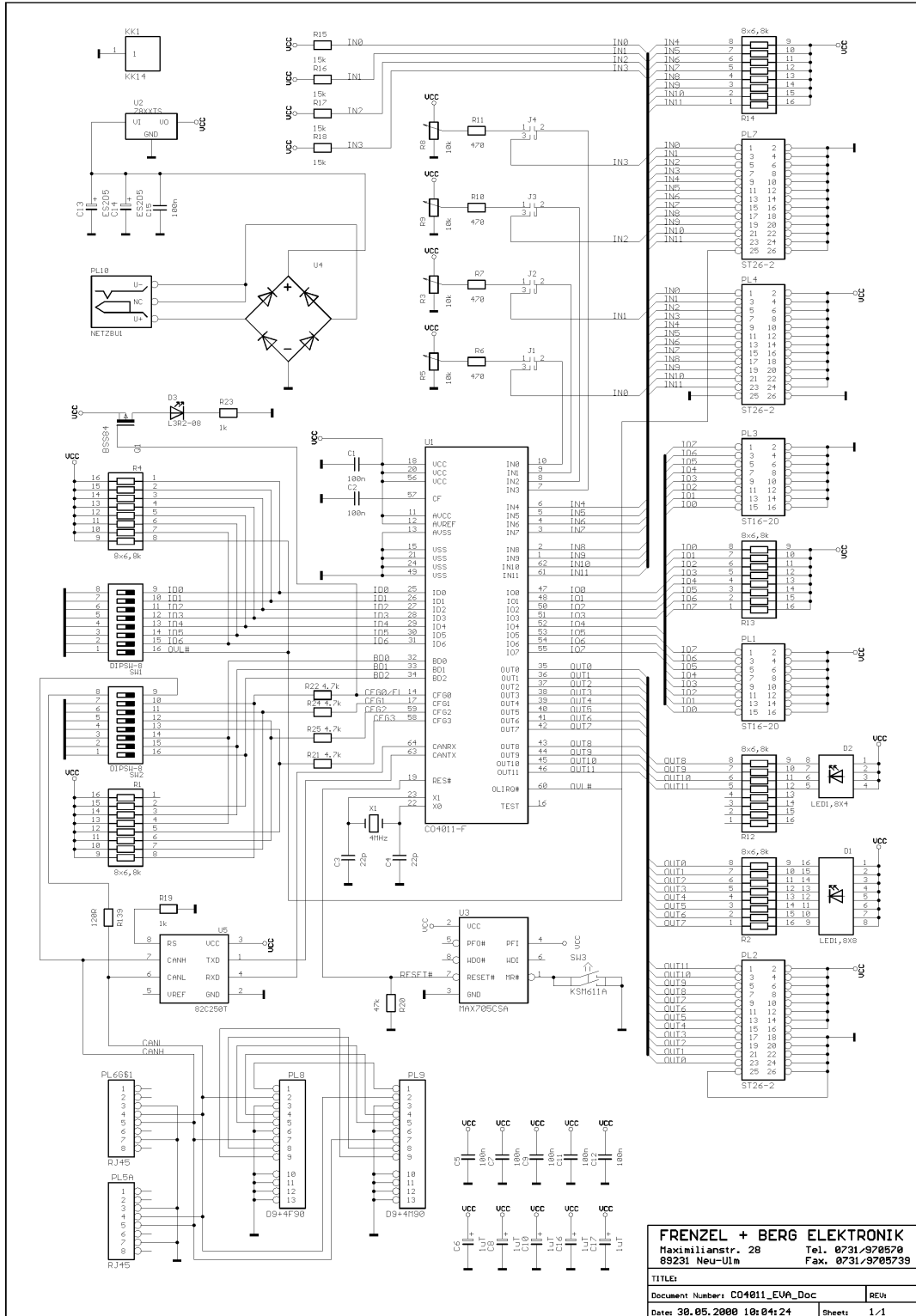

Version History and Notes

Version	Date	Changes
1.37	July/11/2002	Objects 6100, 6120, 6300, 6320 added 16 / 32 Bit access to digital I/O Object 2FF9 added Power down mode can be activated with NMT command "Stop Node"
1.38	Dez/10/2002	Transmission for PDOs keeping analog input data improved
1.39	May/19/2003	Object 5200 added In case of an emergency condition that forces the output pins to the error state, The error state is copied into object 6200. So a return from error condition does not set the output stages to their active levels, but keeps the error condition.

The information herein is given to describe certain components and shall not be considered as warranted characteristics. Terms of delivery and all rights to technical changes are reserved.

We hereby disclaim any and all warranties, including but not limited to warranties of non-infringement, regarding circuits, descriptions and charts stated herein.

General Description	1	DS301: Global Objects	11
Features	1	Index 1000 : Device Type	11
Applications	1	Index 1001 : Error Register	11
CANopen Features	1	Index 1002 : Status Register	11
Ordering Information	1	Index 1005 : COB-ID Sync	11
Pin Assignment	2	Index 1008 : Device Name	12
Pin Listing	2	Index 1009 : Hardware Version	12
Pin Listing continued	2	Index 100B : Node-ID	12
Handling the Device	2	Index 100C : Guard Time	13
Preventing latch up	2	Index 100D : Life Time Factor	13
Handling unused Pins	2	Index 100E : COB-ID Guard	13
Power Supply Pins	2	Index 1010 : Store Parameters	13
Power Supply for A/D converter	3	Index 1011 : Restore Default Parameters	14
Input / output pins	3	Index 1014 : COB-ID Emergency	14
Pull up/down resistors	3	Index 1015 : Inhibit Time Emergency	15
Pin Description	3	Index 1017 : Producer Heartbeat Time	15
IN0 to IN11: Digital or analog input pins	3	Index 1018 : Identity Object	15
OUT0 to OUT12: Digital output pins	3	Index 2000 : Device Manufacturer	16
IO0 to IO7: Digital input or output pins	3	Index 2100 : New Node ID	16
CF: Filter Capacitor input	3	Index 2101 : System Configuration	16
X0, X1: Crystal oscillator input	3	Index 2110 : Enable Boot Up Message	16
TEST: Reserved pin	4	Index 2180 : CAN Restart Time	16
OLIRQ#: Output Overload Interrupt	4	DS301: PDO Parameter Objects	17
VCC, AVCC, VSS, AVSS: Power Supply Pins	4	Communication Parameter Objects	17
RES#: Reset input pin	4	PDO Mapping Objects	18
CFG0 to CFG2: Configuration input pins / LED output pins	4	DS401: Digital Input Objects	19
CFG3/WD: Configuration input / watchdog output	4	Index 5001/2 : Write to Digital Input	19
CANRX, CANTX: CAN interface pins	4	Index 5003 : Filter Time Digital Input	20
In Circuit programming of MB90F497	5	Index 6000 : Read Digital Input 8 Bit	20
Device Configuration	6	Index 6100 : Read Digital Input 16 Bit	21
CAN Identifier	6	Index 6120 : Read Digital Input 32 Bit	21
Baud rate	6	Index 6002 : Polarity Input 8 Bit	21
Analog Input Selection	6	Index 6003 : Filter Enable Input 8 Bit	21
Configuration of IO-Port	6	Index 6005 : Global Interrupt Enable	21
Enable additional CAN features	6	Index 6006 : Interrupt Mask Any Change	22
Power Down Mode	7	Index 6007 : Interrupt Mask Low to High	22
Activate Power-Down	7	Index 6008 : Interrupt Mask High to Low	22
Return from Power-Down	7	DS401: Digital Output Objects	22
Emergency-Message	7	Index 5200 : Output Reset on Error Option	22
Object Dictionary	8	Index 6200 : Write to Digital Output	22
DS301: global Objects	8	Index 6300 : Write Digital Output 16 Bit	23
DS301: PDO Parameter Objects	9	Index 6320 : Write Digital Output 32 Bit	23
DS401: Digital Input Objects	9	Index 6202 : Polarity Output 8 Bit	23
DS401: Digital Output Objects	10	Index 6206 : Error Mode Output 8 Bit	23
DS401: Analog Input Objects	10	Index 6207 : Error Value Output 8 Bit	24
Additional Objects for Power Down	10	DS401: Analog Input Objects	24
Description of Object Dictionary	10	Index 6400 : Read Analog Input 8 Bit	24
Index 0005	10	Index 6401 : Read Analog Input 16 Bit	25
Index 0006	10	Index 6421 : Analog Input Interrupt Trigger	25
Index 0007	10	Index 6423 : Analog Input Interrupt Enable	26
		Index 6424/5/6/7/8 : Analog Input Interrupt Limits	26
		Index 6431 : Analog Input Offset	27
		Power Down Control Objects	27
		Index 2FF9 : Power Down with Stop Node	27
		Index 2FFA : Wake-Up-Confirm-Time	27
		Index 2FFB : Power-Down-Delay-Time	28
		Index 2FFC : Wake-Up-Counter	28

Index 2FFD : Reset Power Down Input Pin Enable..	28
Index 2FFE : Power-Down-Enable.....	28
Index 2FFF : Switch-To-Power-Down-Mode.....	29
Mapping I/O to Object Dictionary.....	29
Summary of operation modes.....	29
20 digital in / 12 digital out.....	30
12 digital in / 20 digital out.....	30
16 dig. in / 12 dig. out / 4 analog in 16 bit.....	30
8 dig. in / 20 dig. out / 4 analog in 16 bit.....	30
12 dig. in / 12 dig. out / 8 analog in 8 bit.....	31
4 dig. in / 20 dig. out / 8 analog in 8 bit.....	31
Absolute Maximum Ratings.....	32
Recommended Operation Conditions and Characteristics.....	32
Package Dimension CO4011A.....	33
Typical Application: EVA board for CO4011.....	34
Version History and Notes.....	35