

General Description

The CO4012 is a low cost, high performance Single Chip solution for CANopen remote I/O modules and especially designed for automotive and industrial applications. The device offers the complex implementation of the CANopen standards DS301 and DS401 in a single chip. It is suitable for simple low cost applications like sensor interfacing as well as for complex I/O systems.

CO4012 provides up to 32 digital I/O lines. 8 channels may be set for analog input operation with a resolution of 10 bits. To support output overload monitoring, a special error interrupt input is provided. All usual baud rates up to 1 MBit are supported.

The CO4012 Chip requires only few external components, just like a crystal, a CAN transceiver and capacitors. To minimize external interface recommendations all output pins have high current drive capability of 4 mA. For interfacing opto isolators no external drivers are required.

CO4012 is a software solution to run on Fujitsu MB90F497 micro controller. It is offered either as software runtime licence or as ready-programmed chip (runtime licence included).

Features

- Single Chip CANopen Controller
- According to CiA Draft Standards DS301 Version 4.0 and DS401 Version 2.0
- Baudrate up to 1MBit
- Various I/O configurations
- Internal noise filtering for all inputs with individual setting for each channel
- Error interrupt input for output overload monitoring
- Output drivers with 4mA
- Watchdog output
- Temperature ranges up to -40 to 105 °C
- Package QFP64

Applications

The CO4012 CANopen Controller is optimised for automotive and industrial applications such as:

- CANopen Remote I/O Modules
- CANopen Interface for keyboards and control panels
- Low Cost CANopen Interface for sensors like photoelectric reflex switches photo interrupters etc.
- Low Cost CANopen Interface for actors like pneumatic valves, warning panels etc.



CANopen Features

- 2 Transmit- and 1 Receive PDOs (configuration dependent)
- Dynamic PDO mapping
- Variable PDO identifier
- All CANopen specific PDO transmission types supported: synchronous, asynchronous, event driven, cyclic, acyclic and remote frame dependent.
- Additional manufacturer specific transmission mode for CAN-EASY applications.
- Event timer and inhibit timer features for all transmit PDOs.
- Storing and restoring of object dictionary to non-volatile memory
- Nodeguarding, Lifeguarding, Heartbeat
- Variable SYNC identifier
- Emergency messages
- Minimum boot up

Ordering Information

CO4012 Chip (programmed, licence included)

Part	Temp. Range	Package
CO4012A-FL	-40 °C to 85 °C	QFP64
CO4012AE-FL	-40 °C to 105 °C	QFP64

Software licence

Part	Description
CO4012SRL-F	Software runtime licence for Fujitsu MB90F497 controller

Pin Assignment

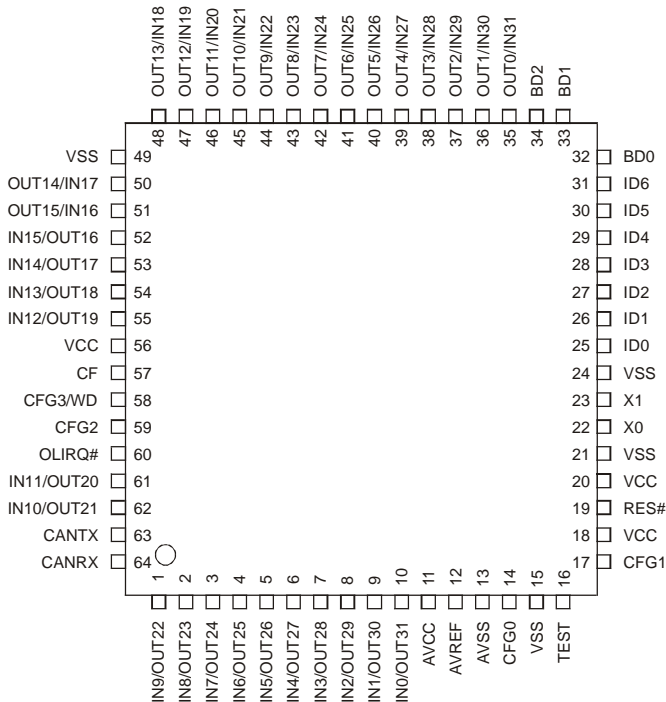

Pin Listing continued

Pin No.	Pin Name	Funktion
35..48, 50..51	OUT0/IN31 .. OUT15/IN16	Digital output/input active low
52..55, 61..62	IN15/OUT16 .. IN10/OUT21	Digital input/output active low
57	CF	Filter capacitor
60*	OLIRQ# *	Output overload interrupt input active low
63	CANTX	Transmitter output of CAN module
64	CANRX	Receiver input of CAN module
15, 21*, 24, 49	VSS	Ground
18*, 20, 56	VCC	Power supply

* Pins are used for in circuit programming of Fujitsu MB90F497. See "in circuit programming manual" for further information.

Pin Description

All input / output pins are high impedance during reset. The CO4012 does not support internal pull up/down resistors. Use external components where needed. All input pins have Schmitt trigger characteristics. See chapter "Typical Applications" for additional information.

OUTx/INx and INx/OUTx: Digital I/O pins

Digital I/O lines depending on system configuration. The function is selected with the Configuration input pins CFG0 to CFG2.

All output pins have high current drive capabilities of approximate 4 mA for direct interfacing for optocouplers without additional drivers.

Note: Digital output pins are active low. This means that received output data from PDO is written with inverted values to output pins.

The CO4012 provides optional output inverters with individual setting for each channel. See chapter "Object Dictionary" for details.

Note: Digital input pins are active low. This means that digital input pins are mapped with inverted values to transmit PDO data.

The CO4012 provides optional input inverters and internal noise filtering for all inputs with individual setting for each channel. See chapter "Object Dictionary" for details.

Pin Listing

Pin No.	Pin Name	Funktion
1 to 2	IN9/OUT22 .. IN8/OUT23	Digital input/output active low
3 to 10	IN7/OUT24 .. IN0/OUT31	Analog input or digital input/output active low according to setting of CFG0 .. CFG3
11	AVCC	Supply for A/D-Converter
12	AVREF	Reference Voltage for A/D-Converter
13	AVSS	Ground for A/D-Converter
14, 17, 59	CFG0 .. CFG2	Configuration bits 0 to 3 for I/O setting
58	CFG3/WD	Enable additional CAN features input and watchdog output
16	TEST	Do not connect this pin
19	RES#	Reset input active low
22	X0	Crystal oscillator input
23	X1	Crystal oscillator output
25* 26*	ID0*, ID1*	Identifier selection input
27 .. 31	ID2 .. ID6	Identifier selection input
32..34	BD0 to BD2	Baud rate selection input

IN0/OUT31 to IN7/OUT24: Digital I/O or analog input pins

General purpose I/O pins with analog input capabilities. The function depends on setting of configuration bits CFG0 to CFG2. See also chapter "Mapping I/O to Object Dictionary" for details. In case of analog input mode, a resolution of 10 Bit is provided. Nevertheless the analog values are mapped as signed integer values to the object dictionary.

CF: Filter Capacitor input

For correct operation of the CO4012 a ceramic capacitor of 100 nF or 220 nF must be connected between Pin 57 (CF) and VSS. Place this component as close as possible to the CO4012.

X0, X1: Crystal oscillator input

Connect a crystal of 4 MHz between X0 and X1. Use additional ceramic capacitors of 22 pF between X0 and X1 to VSS.

TEST: Reserved pin

Leave pin TEST unconnected.

OLIRQ#: Output Overload Interrupt

This active low input pin is provided to support output overload monitoring. Connect output from output overload control circuit to this input pin. If the CO4012 scans a low level on pin OLIRQ#, the device automatic enters the error state given in Object 67FE.02 (default enter preoperational state). Further more the Error Register (index 1001) is set to 0x01, indicating a current error.

Last but not least the device will send an emergency telegram with error code 0x2310 indicating an overload error.

If output overload monitoring is not to be used in your application, make sure, that pin OLIRQ# is forced to logic high level.

VCC, AVCC, VSS, AVSS: Power Supply Pins

Make sure that all ground and power supply pins are connected to the same potential. Do not leave any ground or power supply pins open. Connect decoupling capacitors as close as possible to the device. See chapter "Recommended Operation Conditions" for details

RES#: Reset input pin

For a correct device reset, provide an active low reset signal according to recommended operation conditions to input RES#.

CFG0 to CFG2: Configuration input pins

Set device configuration to preferred operation mode using CFG0 to CFG3. Leaving any configuration input unconnected may cause malfunction of the device. It is strongly recommended forcing all configuration input bits to either high or low level by using external pull up/down resistors. Do not use direct connection to VCC or VSS.

Note: CFGx are input pins during start up and output pins in normal operation mode. In order to prevent short circuit overload, a series resistor between CFGx and configuration device (example DIP switch) should be used. See also "typical application" for details.

CFG3/WD: Configuration input / watchdog output

CFG3/WD is scanned during reset to switch the CO4012 to enable additional CAN features. Then CFG3/WD is switched to output and drives the watchdog trigger. To monitor correct device operation, this feature may be used in combination with an external watchdog timer.

CANRX, CANTX: CAN interface pins

The CAN interface pins may be used for direct connection to CAN transceivers like the 80C251. For longer bus length or noisy or disturbed environments it is strongly recommended to use galvanic isolation with optocouplers between bus interface and CANopen application, to improve system reliability.

Handling the Device

Preventing latch up

The CO4012 is a CMOS device and may suffer latch up under the following conditions:

- 1) A voltage higher than VCC or lower than VSS is applied to any pin.
- 2) Absolute maximum ratings are exceeded
- 3) AVCC power is provided before VCC supply

Handling unused Pins

Do not leave unused input pins open. This might cause malfunction of the device.

Power Supply Pins

Make sure that all ground and power supply pins are connected to the same potential. Do not leave any ground or power pins open. Connect at least two ceramic capacitors of 100 nF and a tantalium capacitor of 1 uF between VCC and VSS as close as possible to the device.

Power Supply for A/D converter

The power supply for the A/D converter must not be turned on before the power supply VCC. If the A/D converter is not used, connect the pins as follows: AVCC = VCC, AVSS = AVREF = VSS.

Input / output pins

All input and output pins for digital signals are active low. This means for input pins, that inverted pin level is mapped to PDO. For output pins the inverted byte value from received PDO is written to the output pins. Additional inverting capabilities are supported.

Pull up/down resistors

The CO4012 does not support internal pull up/down resistors. Use external components where needed.

Pin No.	Pin Name	Pin Setting for in circuit programming
21	VSS	Level = High
18	VCC	Level = Low
25	ID0	Level = Low
26	ID1	Level = Low
60	OVL#	RXD (TTL – logic level)
62	IN10	TXD (TTL – logic level)

Design example for programming adaptor.

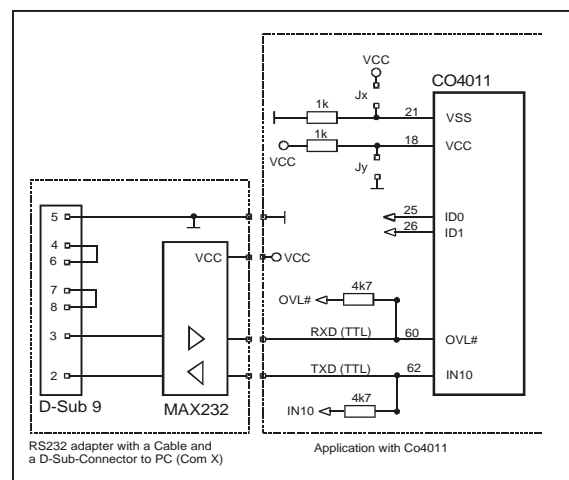

In Circuit programming of MB90F497

If you want to enable in circuit programming of the Fujitsu MB90F497 micro controller for CO4012 software download or update, the following conditions must be met.

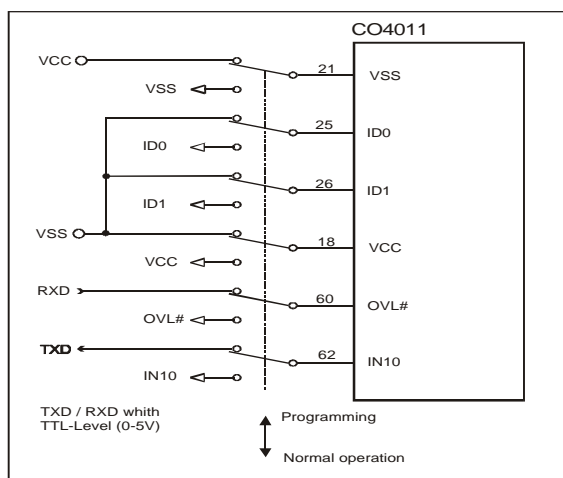

To enable the programming condition chose an identifier that forces the Pins ID0 and ID1 to low level. For example identifiers ID= 3, 7, 0x0B, 0x0F ... might be used. Close the jumpers Jx and Jy.

For optimised programming adaptor design, the programming adaptor should close the jumpers Jx and Jy directly by plugging the adaptor into the application board.

For normal operation mode the programming adaptor must be removed.

Device Configuration

The following sections describe the device configuration with meaning:

- 1: ViH logic high level
- 0: ViL logic low level

CAN Identifier

The CAN Identifier will be set with Pins ID0 to ID6. This configuration pins use internal inverter. The ID is set as follows:

ID6	ID5	ID4	ID3	ID2	ID1	ID0	CAN-Identifier
1	1	1	1	1	1	1	Programmable ID
1	1	1	1	1	1	0	1 = 0x01
1	1	1	1	1	0	1	2 = 0x02
1	1	1	1	1	0	0	3 = 0x03
1	1	1	1	0	1	1	4 = 0x04
		
1	0	0	0	0	0	0	63 = 0x3F
0	1	1	1	1	1	1	64 = 0x40
0	1	1	1	1	1	0	65 = 0x41
		
0	0	0	0	0	1	0	125 = 0x7C
0	0	0	0	0	0	1	126 = 0x7E
0	0	0	0	0	0	0	127 = 0x7F

All Identifiers from 1 to 127 are valid settings. Identifier 0 is used to load the ID from object 2100.

Baud rate

The baud rate configuration will be done with configuration inputs BD0 to BD2

BD2	BD1	BD0	CAN-Baud Rate / Bus length
1	1	1	1 Mbit/sec 25 m *1)
1	1	0	800 kbit/sec 50 m *1)
1	0	1	500 kbit/sec 100 m *2)
1	0	0	250 kbit/sec 250 m *2)
0	1	1	125 kbit/sec 500 m *3)
0	1	0	50 kbit/sec 1000 m *3)
0	0	1	20 kbit/sec 2500 m *3)
0	0	0	10 kbit/sec 5000 m *3)

- *1) Calculation without optocouplers.
For optocouplers bus length is reduced for about 4m per 10 nsec propagation delay of employed optocoupler type
 - *2) Calculation with 40 nsec optocoupler propagation delay
 - *3) Calculation with 100 nsec optocoupler propagation delay
- The calculation of the bus length is based on a line propagation delay of 5 nsec/m.

Operation Mode Selection

Configuration bits CFG0 to CFG1 select the I/O configuration of the CO4012 chip.

CFG	Configuration
2 1 0	Pin functions
1 1 1	16 digital Input, 16 digital Output IN0/OUT31..IN15/OUT16: Input line 0..15 OUT0/IN31..OUT15/IN16: Output line 0..15
1 1 0	32 digital Input Lines IN0/OUT31..IN15/OUT16: Input line 0..15 OUT15/IN16..OUT0/IN31: Input line 16..31
1 0 1	32 digital Output Lines OUT0/IN31..OUT15/IN16 Output 0..15 IN15/OUT16..IN0/OUT31 Output 16..31
1 0 0	8 analog Input (10 bit resolution) IN0/OUT31..IN7/OUT24
	Analog Input line 0..7
0 x x	Reserved for future use do not use this combination

Do not apply higher voltages than VCC and AVCC to any input pin. If the A/D converter is not used, connect the power supply pins as follows:
AVCC = VCC, AVSS = AVREF = VSS.

Enable additional CAN features

With setting CFG3 to 0 the following special features may be enabled:

- Easy Mapping of Objects to PDO

CFG3	I/O Port is used for
1	Normal operation mode
0	Enable additional features.

Note

These features might be incompatible with CANopen conformance Test.

Power Down Mode

During power down, the CO4012 stops working completely. The oscillator is stopped. The CO4012 keeps its NMT state (operational, preoperational).

The complete power down extension is switchable on and off, so that the same chip can be used for standard applications as well.

In power down configuration a Wake-Up-Interrupt-Input (WUII pin2) can be used for wake up by CAN bus line and optional an additional Reset-Power-Down-Input (RPDI: pin1) may be used for system wake up by a push button or something like that. Both inputs are active low. WUII must be directly connected to CANRX (pin 64) on the application board if wake up by CAN bus line (telegram) is wanted. A counter is implemented which counts the number of the return from power down operations.

All output lines keep unchanged during the power down state.

For power down control 6 objects are added to the object dictionary of the CO4012:

- Power-Down Enable
- Switch to Power-Down Mode
- Reset Power Down Input Enable
- Wake Up Counter
- Power-Down Delay Time
- Wake-Up-Confirm-Time

Activate Power-Down

To enable the power down mode the following actions are necessary

The object Power-Down-Enable (2FFE) has to be written to with the signature 0x5044454E ("PDEN"). With that the pin WUII is configured at the same time. The signature can be written by SDO transfer but it may also stay saved together with the object dictionary in the chips non-volatile memory.

To activate Power-Down, write the signature "POFF" 0x504F4646 to object "Switch to Power-Down-Mode" (2FFF). This access must be done by SDO transfer.

After the CO4012 has recognized a power down instruction, it is waiting until the SDO answer telegram was sent to the bus. After an additional waiting time corresponding to the "Power-Down Delay Time" object, the CO4012 switches in power-down mode.

Return from Power-Down

If pin WUII (Wake-Up-Interrupt-Input) is connected to CANRX the CO4012 can be waked up by any CAN telegram. Even a level change on the CAN bus line is enough.

The CO4012 restarts the CAN module after handling the interrupt and scans incoming telegrams. If a valid NMT telegram is received on identifier 0 during a time out corresponding the "Wake-Up-Confirm-Time" object, the CO4012 switches back to normal operation mode. Otherwise the power down state is activated again.

Attention:

Because of the different start up times of the oscillator during wake up it could happen, that the CO4012 already interprets the wake up telegram as a valid CAN message. This can not be guaranteed. That's why an identifier should be selected for wake up, which isn't used by a CAN message in the application.

An emergency telegram is sent during wake up by Reset Power Down Input pin and so the normal run is started up without any additional CAN message needed.

The wake up counter is incremented by each wake up event. That is irrespective of whether a correct NMT telegram also will be recognized or not after a wake up interrupt by CAN bus. Therefore a definite handling how many wake up events were done is possible.

Emergency-Message

The CO4012 sends the emergency telegram after wake up by pin "Reset Power Down Input" with the following content:

Error-Code	0xF000
Error Register	0x01
Manufacturer specific Error Field	0

After an additional waiting time which corresponds to the "Wake-Up-Confirm-Time" object, an additional emergency telegram with content 0 is sent. This indicates the reset of all errors.

Object Dictionary

The CO4012 Single Chip CANopen Controller implements a complex object dictionary for CANopen I/O devices.

For detailed information about CANopen objects see additional brochure "Introduction to CANopen"

For the Object tables all values are shown in hexadecimal way.

For access type the following settings are valid

ro read only
wo write only
rw read and write access enabled

DS301: global Objects

Index	Sub-Index	Name	Acc.
0005	-	Dummy 8	ro
0006	-	Dummy 16	ro
0007	-	Dummy 32	ro
1000	-	Device Type	ro
1001	-	Error Register	ro
1002	-	Manufacturer Status Register	ro
1005	-	COB-ID Sync Identifier Sync Object	rw
1008	-	Device Name	ro
1009	-	Hardware Version	ro
100C	-	Guard Time	rw
100D	-	Life Time Factor	rw
100E	-	COB-ID Guard	rw
1010	-	Store Parameters *1)	rw
1011	-	Reload Default Parameter *1)	rw
1014	-	COB ID Emergency	rw
1015	-	Inhibit Time Emergency	rw
1017	-	Producer Heartbeat Time	rw
1018	0	Identity Object	ro
	1	Vendor ID	ro
	2	Product Code	ro
	3	Revision Number	ro
	4	Serial Number	ro
2000	-	Device Manufacturer *3)	ro
2100	-	New Node Id *4)	rw
2101	-	System Configuration	ro
2102	-	New Baud Rate *5)	rw
2110	-	Enable Boot Up Message	rw
2180	-	CAN Restart Time	rw

Notes:

- *1) This object cannot be written to in operational device state.
Only use this command in preoperational device state, otherwise the CO4012 will answer requests with SDO abort telegrams.
- *3) This object shows "Frenzel + Berg" as visible string data type. If OEMs do not want to give access to this entry, it may be removed from the EDS (electronic data sheet).
- *4) The New Node Id object gives the possibility to set a Node-Nr independent from the Node-Id Input Bits. With this feature the device may be configured by CAN bus line.
- *5) The New Baud Rate object gives the possibility to set a baud rate independent from the baud rate input bits. With this feature the device may be configured by CAN bus line.

This feature will not be implemented in the first step of the device

The data type entries Index 0005 to 0007 are implemented for compatibility reasons. They may be mapped to PDOs in order to define the appropriate space in the PDO.

For the read only objects following data is set:

Index	Sub.	Name	Value in Hex.
1000		Device Type	000x 0191 h *1)
1018	0	Identity Object	04h
	1	Vendor ID	0000 0058 h
	2	Product Code	0104 0121 h
	3	Revision Number	0 .. 0xFFFFFFFF
	4	Serial Number	0
2101		System Configuration	Set according to the setting of the configuration input bits.

Notes:

- *1) Exact code is depending on the configuration.

DS301: PDO Parameter Objects

Description of PDO Parameter objects:

These Objects enable dynamic PDO mapping, variable identifier distribution for PDOs and setting of the transmission mode, inhibit and event times.

For the CO4012 setting of all parameters may be done in the device state "operational" as well as in "preoperational" state.

Index	Sub-Index	Name	Acc.
1400	0	Receive PDO1 Communication Parameter	ro
	1	COB-ID	rw
	2	Transmission Type	rw
	3	Inhibit Time (not used)	rw
	4	Reserved	rw
	5	Event Timer	rw
1401 ... 1403		Receive PDO2 to RPDO4 Communication Parameter same as 1400.00 .. 1400.05	rw
1600	0	Receive PDO1: Parameter mapping	rw
	1 to n	Mapped Object (max. 8 objects mappable)	rw
1601 ... 1603		Receive PDO2 to RPDO4 Parameter mapping Same as 1600	rw
1800	0	Transmit PDO1 Communication Parameter	ro
	1	COB-ID	rw
	2	Transmission Type	rw
	3	Inhibit Time	rw
	4	Reserved	rw
	5	Event Timer	rw
1801 ... 1803		Transmit PDO2 to TPDO4 Communication Parameter same as 1800.00 .. 1800.05	rw
1A00	0	Transmit PDO1 Parameter mapping	rw
	1 to n	Mapped Object (max. 8 objects mappable)	rw
1A01 ... 1A03		Transmit PDO2 to TPDO4 Parameter mapping Same as 1A00	rw

Note:

The CO4012A supports only 1 receive and 2 transmit PDOs. All Objects for higher PDO numbers are not implemented.

Note:

For detailed information about CANopen objects see additional brochure "Introduction to CANopen"

DS401: Digital Input Objects

Index	Sub-Index	Name	Acc.
5001	0 to n	Write 1 to digital input 8 bit	rw
5002	0 to n	Write 0 to digital input 8 bit	rw
5003	0 to n	Filter time for each digital input	rw
6000	0 to n	Read digital input 8 bit	ro
6002	0 to n	Polarity input 8-bit	rw
6003	0 to n	Filter constant enable 8 bit	rw
6005		Global interrupt enable	rw
6006	0 to n	Interrupt mask: any change	rw
6007	0 to n	Interrupt mask rising edge	rw
6008	0 to n	Interrupt mask falling edge	rw

The objects 5001 and 5002 are implemented for debug purposes, because the CANopen object 6000 does not allow write access to an input line. With objects 5001 and 5002 a debug environment may simulate setting or resetting of input lines. The CO4012 first scans the physical input lines and then processes the scanned values with the debug parameters.

Index 5001 and 5002 make direct bit manipulation of single bits possible.

Index 5001 enables bit setting by using a bit wise logical OR conjunction with index 6000 while index 5002 performs a logical AND conjunction with index 6000 and therefore enables resetting of single bits.

Objects 5001 and 5002 are always working in continuous execution mode. This means that logical operations with object 6000 are performed in each internal input scan cycle

With object 5003 an individual filter constant (value in msec) may be assigned to each input line. This gives great flexibility to prevent inputs from distortion. The default value for filter constant is 5msec. The filter constants enable object is at index 6003.

DS401: Digital Output Objects

Index	Sub-Index	Name	Acc.
6200	0 to n	Write Output 8 Bit	rw
6202	0 to n	Change Polarity Output 8 bit	rw
6206	0 to n	Error Mode Output	rw
6207	0 to n	Error State Output	rw

DS401: Analog Input Objects

Index	Sub-Index	Name	Acc.
6400	0 to n	Read Analog Input 8 Bit *1)	ro
6401	0 to n	Read Analog Input 16 Bit *2)	ro
6421	0 to n	Analog Input Interrupt Trigger	rw
6423		Analog Input global Interrupt Enable	rw
6424	0 to n	Analog Input Upper Limit	rw
6425	0 to n	Analog Input Lower Limit	rw
6426	0 to n	Analog Input Interrupt Delta	rw
6427	0 to n	Analog Input Interrupt Negative Delta	rw
6428	0 to n	Analog input interrupt positive delta	rw
6431	0 to n	Analog input offset integer	rw

*1) These objects are only valid for configuration bits CFG1= 1 and CFG0= 0

*2) These objects are only valid for configuration bits CFG1= 0 and CFG0= x

Additional Objects for Power Down

Index	Sub-Index	Name	Acc.
2FFA	0	Wake Up Confirm Time	rw
2FFB	0	Power Down Delay Time	rw
2FFC	0	Wake Up Counter	rw
2FFD	0	Reset Power Down Input Enable	rw
2FFE	0	Power Down Mode Enable	rw
2FFF	0	Switch To Power Down Mode	rw

Description of Object Dictionary

The following list gives a short description of all dictionary entries.

Index 0005

This object is implemented to enable reservation of data space in PDOs by mapping dummy entries.

Index	0005
Name	Dummy 8
Description	
Data Type	Unsigned 8
Access modes	RO
PDO Mapping	Yes
Value Range	-
Default Value	0

Index 0006

This object is implemented to enable reservation of data space in PDOs by mapping dummy entries.

Index	0006
Name	Dummy 16
Description	-
Data Type	Unsigned 16
Access modes	RO
PDO Mapping	Yes
Value Range	-
Default Value	0

Index 0007

This object is implemented to enable reservation of data space in PDOs by mapping dummy entries.

Index	0007
Name	Dummy 32
Description	-
Data Type	Unsigned 32
Access modes	RO
PDO Mapping	Yes
Value Range	-
Default Value	0

DS301: Global Objects

Index 1000 : Device Type

Description of the device type. The Object gives the CiA device profile number and additionally the functionality of the device.

Index	1000h														
Name	Device Type														
Description	-														
Data Type	Unsigned 32														
Access modes	RO														
PDO Mapping	No														
Value Range	-														
Default Value	<table border="1"> <thead> <tr><th>Operation Mode</th><th>Value of Index</th></tr> </thead> <tbody> <tr><td>CO4012A0</td><td>0003 0191 h</td></tr> <tr><td>CO4012A1</td><td>0001 0191 h</td></tr> <tr><td>CO4012A2</td><td>0002 0191 h</td></tr> <tr><td>CO4012A3</td><td>0004 0191 h</td></tr> <tr><td></td><td></td></tr> <tr><td></td><td></td></tr> </tbody> </table>	Operation Mode	Value of Index	CO4012A0	0003 0191 h	CO4012A1	0001 0191 h	CO4012A2	0002 0191 h	CO4012A3	0004 0191 h				
Operation Mode	Value of Index														
CO4012A0	0003 0191 h														
CO4012A1	0001 0191 h														
CO4012A2	0002 0191 h														
CO4012A3	0004 0191 h														

Index 1001 : Error Register

This object holds an error of the device.

Index	1001h
Name	Error Register
Description	-
Data Type	Unsigned 8
Access modes	RO
PDO Mapping	Yes
Value Range	-
Default Value	-

The error register has the following structure

Bit	Meaning
0	Generic error. This bit is set, if any error is active
1	0
2	0
3	0
4	CAN bus or communication error
5	0
6	0
7	Device Error

Index 1002 : Status Register

This object gives additional information for the device

Index	1002h
Name	Status Register
Description	-
Data Type	Unsigned 32
Access modes	RO
PDO Mapping	Yes
Value Range	-
Default Value	-

The status register bits have the following meaning

Bit	Meaning
31	The device is in operational state
30	Node guarding error
23	I/O error output overload error

Index 1005 : COB-ID Sync

Identifier of Can Object for the Synchronisation message. The CO4012 may only operate in Sync consumer mode. Generating of Sync messages is not possible. Nevertheless is the Identifier for the Sync message programmable.

Index	1005h
Name	COB-ID Sync
Description	-
Data Type	Unsigned 32
Access modes	RW
PDO Mapping	No
Value Range	-
Default Value	80h

Index 1008 : Device Name

This object shows the name of the device as visible string.

Index	1008h
Name	Device Name
Description	-
Data Type	Visible String
Access modes	RO
PDO Mapping	No
Value Range	The maximum string length is 20 characters
Default Value	CO4012A

Index 1009 : Hardware Version

This object shows the hardware version of the device as visible string.

Index	1009h
Name	Hardware Version
Description	-
Data Type	Visible String
Access modes	RO
PDO Mapping	No
Value Range	The maximum string length is 20 characters
Default Value	-

Index 100B : Node-ID

This object keeps the actual node ID. The Object is not represented in the object dictionary because of standard conforming reasons.

Index	100Bh
Name	Node ID
Description	-
Data Type	Unsigned 8
Access modes	Not accessible
PDO Mapping	No
Value Range	1 to 127
Default Value	See below

There are several modes to select a valid node ID. Setting the configuration input bits ID0 to ID6 to any combination other than zero will take the configuration input setting of bits ID0 to ID6 as valid Node-ID.

If setting the configuration input bits ID0 to ID6 to the combination zero (all input bits at high level) will activate the Node-ID object 2100h. With this object a Node-ID may be set independent from the configuration input bits. If Object 2100h has value 0 (default factory setting if not written to by your application or CANopen configuration tool) the Node ID will be forced to 126 (7Eh).

For applications without any configuration switches the following configuration method must be used:

- All configuration input bits ID0 to ID6 must be forced to HIGH level. This will select Node-ID 0 (zero).
- When starting the device for the first time the Node ID will be set to 126 (7Eh).
- Now the Object 2100h may be set to the desired Node ID by using a CANopen configuration tool.
- The last step is to save this setting by using object 1010h.

If the device will be restarted the Node ID will be taken from object 2100h and will be copied to object 100Bh. Additionally the COB-Ids for the Sync-, Emergency-, SDO- and PDO- messages will be modified according to the new Node ID.

Index 100C : Guard Time

The objects at index 100Ch (Guard Time in milliseconds) and 100Dh (Life Time Factor) are used to implement the life guarding protocol. The Guard Time multiplied with the Life Time Factor gives the Life Time in milliseconds.
 It is 0 (zero) if not used.

Index	100Ch
Name	Guard Time
Description	-
Data Type	Unsigned 16
Access modes	RW
PDO Mapping	No
Value Range	
Default Value	0

Index 100D : Life Time Factor

The objects at index 100Ch (Guard Time in milliseconds) and 100Dh (Life Time Factor) are used to implement the life guarding protocol. The Guard Time multiplied with the Life Time Factor gives the Life Time in milliseconds.
 It is 0 (zero) if not used.

Index	100Dh
Name	Life Time Factor
Description	-
Data Type	Unsigned 16
Access modes	RW
PDO Mapping	No
Value Range	
Default Value	0

Index 100E : COB-ID Guard

Identifier of Can Object for the Node Guarding protocol.

Index	100Eh
Name	COB-ID Guard
Description	-
Data Type	Unsigned 32
Access modes	RW
PDO Mapping	No
Value Range	-
Default Value	700h + Node-ID

Index 1010 : Store Parameters

This object supports the saving of parameters in non-volatile memory. By read access the device provides information about its saving capabilities. Several parameter groups are distinguished:
 Sub-Index 0 contains the largest Sub-Index that is supported.

Writing to Sub-Index 1 means that all parameters shall be stored on the device.

In order to avoid storage of parameters by mistake, storage is only executed when a specific signature is written to the appropriate Sub-Index. (This means that the signature is transferred as data bytes 4 to 7 in the CAN message of the corresponding SDO protocol.)

The signature is "save".

MSB		LSB	
e	v	a	s
65h	76h	61h	73h

On reception of the correct signature on sub-index 1 the device stores the parameters and then confirms the SDO transmission (initiate download response).
 If the storing failed, the device responds with an Abort SDO Transfer (abort code: 0606 0000 h).
 If a wrong signature is written, the device refuses to store and responds with Abort SDO Transfer (Abort code: 0800 002x h).

Index	1010h
Name	Store Parameters
Description	-
Data Type	Structure

Index	1010h Sub-Index 0
Name	Largest Sub-Index supported
Description	-
Data Type	Unsigned char
Access modes	RO
PDO Mapping	No
Value Range	1
Default Value	1

Index	1010h Sub-Index 1
Name	Store All Parameters
Description	Writing to this object stores the dictionary to non-volatile memory.
Data Type	Unsigned 32
Access modes	RW
PDO Mapping	No
Value Range	Signature "save"
Default Value	-

By read access to object 1010h Sub-Index 1, the device responds with SDO data 00000001h indicating that storing of data is only done on command.

Note:

Writing to this object is only allowed in pre-operational mode.

Index 1011 : Restore Default Parameters

With this object the default values of parameters according to the communication or device profile are restored. By read access the device provides information about its capabilities to restore these values. Several parameter groups are distinguished: Sub-Index 0 contains the largest Sub-Index that is supported.

Writing to Sub-Index 1 restores all parameters that can be restored.

In order to avoid the restoring of default parameters by mistake, restoring is only executed when a specific signature is written to the appropriate sub-index. (This means that the signature is transferred as data bytes 4 to 7 in the CAN message of the corresponding SDO protocol.)

The signature is "load".

MSB		LSB	
d	a	o	l
64h	61h	6Fh	6Ch

On reception of the correct signature on sub-index 1 the device prepares restoring of the parameters at the next "reset node" command or on the next power on cycle and then confirms the SDO transmission (initiate download response). If failed, the device responds with an abort SDO transfer (abort code: 0606 0000h).

If a wrong signature is written, the device refuses to store and responds with Abort SDO Transfer (Abort code: 0800 002x h).

The default values are set valid after the device is reset (reset node) or power cycled. If the device requires storing on command (see Object 1010h), the appropriate command has to be executed after the reset if the default parameters are to be stored permanently.

Index	1011h
Name	Restore Default Parameters
Description	-
Data Type	Structure

Index	1011h Sub-Index 0
Name	Largest Sub-Index supported
Description	-
Data Type	Unsigned char
Access modes	RO
PDO Mapping	No
Value Range	1
Default Value	1

Index	1011h Sub-Index 1
Name	Restore All Parameters
Description	Writing to this object prepares restoring of the default values to the dictionary at the next power cycle or "reset node" NMT.
Data Type	Unsigned 32
Access modes	RW
PDO Mapping	No
Value Range	Signature "load"
Default Value	-

By read access to object 1011h Sub-Index 1, the device responds with SDO data 00000001h indicating that restoring of default data is available.

Note:

Writing to this object is only allowed in pre-operational mode.

Index 1014 : COB-ID Emergency

Identifier of Can Object for the emergency messages.

Index	1014h
Name	COB-ID Emergency
Description	-
Data Type	Unsigned 32
Access modes	RW
PDO Mapping	No
Value Range	-
Default Value	80h + Node-ID

Index 1015 : Inhibit Time Emergency

Inhibit Time for emergency messages. If the Inhibit Time is set to 0, inhibit delay is disabled. The Inhibit Time is a multiple of 100usec, but the CO4012A offers a maximum resolution of 1 millisecond.

Index	1015h
Name	Inhibit Time Emergency
Description	-
Data Type	Unsigned 16
Access modes	RW
PDO Mapping	No
Value Range	-
Default Value	0

Index 1017 : Producer Heartbeat Time

The producer heartbeat time defines the cycle time of the heartbeat. The producer heartbeat time is 0 if it not used. The time has to be a multiple of 1ms.

Index	1017h
Name	Producer Heartbeat Time
Description	-
Data Type	Unsigned 16
Access modes	RW
PDO Mapping	No
Value Range	-
Default Value	0

Note:

Either Heartbeat or node guarding may be allowed at the same time. Do not use both protocols at the same time.

See additional brochure for further information about heartbeat protocol.

Index 1018 : Identity Object

The object at index 1018h contains general information about the device and the manufacturer frenzel + berg elektronik. It cannot be modified.

Index	1018h
Name	Identity Object
Description	-
Data Type	Structure

Index	1018h Sub-Index 0
Name	Largest Sub-Index supported
Description	-
Data Type	Unsigned char
Access modes	RO
PDO Mapping	No
Value Range	-
Default Value	4

Index	1018h Sub-Index 1
Name	Vendor ID
Description	Registration Code of frenzel + berg elektronik at the CiA
Data Type	Unsigned 32
Access modes	RO
PDO Mapping	No
Value Range	-
Default Value	58h

Index	1018h Sub-Index 2
Name	Product Code
Description	Internal Product Code for CO4012A at frenzel + berg elektronik
Data Type	Unsigned 32
Access modes	RO
PDO Mapping	No
Value Range	-
Default Value	0104 0121 h

Index	1018h Sub-Index 3
Name	Revision Code
Description	
Data Type	Unsigned 32
Access modes	RO
PDO Mapping	No
Value Range	-
Default Value	Revision of the device

Index	1018h Sub-Index 4
Name	Serial Number
Description	
Data Type	Unsigned 32
Access modes	RO
PDO Mapping	No
Value Range	-
Default Value	

Index 2000 : Device Manufacturer

This Object shows "Frenzel + Berg" as visible string. If OEMs do not want to give access to this entry, it may be removed from the EDS (electronic data sheet).

Index	2000h
Name	Device Manufacturer
Description	-
Data Type	Visible String
Access modes	RO
PDO Mapping	No
Value Range	-
Default Value	"Frenzel + Berg"

Index 2100 : New Node ID

This Object is implemented to enable applications without any switches for setting the node ID. This object enables setting of the node ID by using SDO transfer.

Index	2100h
Name	New Node ID
Description	-
Data Type	Unsigned 8
Access modes	RW
PDO Mapping	No
Value Range	-
Default Value	0

If no node ID is selected with configuration input bits ID0 to ID6. The New Node ID object is enabled. See Index 100B for details in setting the node ID.

Index 2101 : System Configuration

This Object returns the operation mode of the CO4012A. It represents the inverted Setting of the configuration input bits CFG0 to CFG3.

Index	2101h
Name	System Configuration
Description	-
Data Type	Unsigned 32
Access modes	RO
PDO Mapping	No
Value Range	-
Default Value	Depends on CFG0 to CFG3

Index 2110 : Enable Boot Up Message

This Object enables or disables sending of the boot up message. The boot up message is CAN object with the identifier of the node guarding object and only one data byte with value 0 (zero). If object 2110h is set to 0 the boot up message is disabled otherwise it is enabled.

Index	2110h
Name	Enable Boot Up Message
Description	-
Data Type	Unsigned 8
Access modes	RW
PDO Mapping	No
Value Range	-
Default Value	1 (enabled)

Index 2180 : CAN Restart Time

This Object gives the restart time out for the CAN communication layer in case of bus off errors in milliseconds.

If the restart time is set to 0 automatic restart of the device in case of bus off is prohibited.

Index	2180h
Name	CAN Restart Time
Description	-
Data Type	Unsigned 16
Access modes	RW
PDO Mapping	No
Value Range	-
Default Value	0 (restart disabled)

DS301: PDO Parameter Objects

Communication Parameter Objects

The following table shows the communication parameter objects for Index 140x (Receive PDOs) and Index 180x (Transmit PDOs). The tables show Index 1400 as an example for all PDOs

The transmission type (sub-index 2) defines the mode for transmission / reception of the PDO. See table for detailed description of this entry.

Description of transmission type:

Type	PDO transmission				
	cyclic	acyclic	Sync related	Async.	Only on remote
0		X	X		
1-240	X		X		
241-251	Reserved				
252			X		X
253				X	X
254				X	
255				X	

Synchronous (transmission types 0-240 and 252) means that the transmission of the PDO shall be related to the SYNC object. Asynchronous means that the transmission of the PDO is not related to the SYNC object.

A transmission type of zero means that the message shall be transmitted synchronously with the SYNC object but not periodically but only in case of data change.

A value between 1 and 240 means that the PDO is transferred synchronously and cyclically, the transmission type indicating the number of SYNC signals, which are necessary to trigger PDO transmissions or receptions.

The transmission types 252 and 253 mean that the PDO is only transmitted on reception of a remote frame. At transmission type 252, the data is updated (but not sent) immediately after reception of the SYNC object. At transmission type 253 the data is updated at the reception of the remote frame. These values are only possible for transmit PDOs.

Transmission type 254 selects the CanEASY mode. Transmission type 255 means, the application event is defined in the device profile. For receive PDOs the reception of a PDO will update the mapped data (normally the analog or digital outputs).

Sub-index 3h contains the inhibit time. This time is a minimum interval for PDO transmission. The value is defined as multiple of 100ms.

Sub-index 4h is reserved.

In mode 254/255 additionally an event time can be used for TPDO. If an event timer exists for a TPDO (value not equal to 0) the elapsed timer is considered to be an event. The event time is a multiple of 1 ms. This event will cause the transmission of this TPDO in addition to otherwise defined events.

Index	1400h
Name	Receive PDO1 Communication Parameters
Description	-
Data Type	Structure

Index	1400h Sub-Index 0
Name	Largest Sub-Index supported
Description	-
Data Type	Unsigned 8
Access modes	RO
PDO Mapping	No
Value Range	-
Default Value	5

Index	1400h Sub-Index 1
Name	COB-ID
Description	Identifier for CAN-Object for PDO1
Data Type	Unsigned 32
Access modes	RW
PDO Mapping	No
Value Range	-
Default Value	200h + Node-Id

Index	1400h Sub-Index 2
Name	Transmission Type
Description	-
Data Type	Unsigned 8
Access modes	RW
PDO Mapping	No
Value Range	-
Default Value	0FFh

Index	1400h Sub-Index 3
Name	Inhibit Time
Description	-
Data Type	Unsigned 16
Access modes	RW
PDO Mapping	No
Value Range	-
Default Value	0

Index	1400h Sub-Index 4
Name	Reserved
Description	-
Data Type	-
Access modes	-
PDO Mapping	No
Value Range	-
Default Value	-

Index	1400h Sub-Index 5
Name	Event Time
Description	-
Data Type	Unsigned 16
Access modes	RW
PDO Mapping	No
Value Range	-
Default Value	0

The PDO communication parameter objects have the same structure for all PDOs. The following Objects are used. Not all objects are supported in each chip configuration. Please see chapter "Mapping I/O to Object Dictionary" for further information.

Index	PDO
1400h	Receive PDO1 (digital output)
1800h	Transmit PDO1 (digital input)
1801h	Transmit PDO2 (analog input)
1802h	Transmit PDO3 (analog input)

PDO Mapping Objects

The following table shows the PDO Mapping Objects. The principle of PDO mapping is the same for all PDOs. The PDO Mapping table is the cross reference between the Object dictionary entries (for example the data of an digital output byte) and the data field inside an PDO data field (position in the data field of a CAN message for PDO transfer).

Sub-Index 0 determines the valid number of objects that have been mapped. The CO4012 allows a maximum of 8 mapped objects for each PDO. For changing the PDO mapping first Sub-Index 0 must be set to 0 (mapping is deactivated). Then the objects can be remapped. When a new object is mapped by writing a Sub-Index between 1 and 8, the device may check whether the object specified by index /Sub-Index exists. If the object does not exist or the object cannot be mapped, the SDO transfer will be aborted.

If the special CAN features are enabled (CFG3=0), the CO4012 allows adding of additional mapping entries without resetting Sub-Index 0. In this case the device calculates the number of mapped objects by itself and modifies Sub-Index 0 respectively.

Sub-Indexes 1 to 8 keep the pointers of the mapped objects as unsigned 32 values. The value is 0 if there is no mapped object. The structure for these pointers is as follows.

MSB		LSB	
Byte3	Byte2	Byte1	Byte0
Mapped index		Sub-Index	Length

Mapped Index and Sub-Index together are the Pointer to the Object dictionary data to be mapped at this location.

Length gives the length of the mapped object in bits.

The following mapping object uses index 1600 as an example for all mapping objects.

Index	1600h
Name	Receive PDO1 Mapping Parameters
Description	-
Data Type	Array

Index	1600h Sub-Index 0
Name	Largest Sub-Index supported
Description	Number of mapped objects
Data Type	Unsigned 8
Access modes	RW
PDO Mapping	No
Value Range	-
Default Value	According to operation mode

Index	1600h Sub-Index 1 to 8
Name	Mapped object
Description	
Data Type	Unsigned 32
Access modes	RW
PDO Mapping	No
Value Range	-
Default Value	According to operation mode

Example:

As an example for PDO mapping, the following table shows the default mapping for transmit PDO1 in operation mode 0 (16 digital in/16 digital out).

Index	Entry	Explanation
1A00.00	3	There are 3 mapped objects in transmit PDO1
1A00.01	60000108h	First mapped object: Input Byte0
1A00.02	60000208h	First mapped object: Input Byte1
1A00.03	60000308h	First mapped object: Input Byte2

The data of the transmit PDO1 for this example will be three bytes. (Input Bytes 0 to 3)

The PDO mapping objects have the same structure for all PDOs. The following Objects are used.

Index	PDO
1600h	Receive PDO1 (digital output)
1A00h	Transmit PDO1 (digital input)
1A01h	Transmit PDO2 (analog input)
1A02h	Transmit PDO3 (analog input)

All objects with PDO mapping capabilities (not only digital or analog I/O) may be mapped to one of the PDOs. Not all objects are supported in each chip configuration. Please see chapter "Mapping I/O to Object Dictionary" for further information.

DS401: Digital Input Objects

The following objects are describing the functionality of the digital input lines of the CO4012A

Index 5001/2 : Write to Digital Input

The object 5001 and 5002 are implemented for debug purposes, because the CANopen object 6000 does not allow write access to an input line. With objects 5001 and 5002 a debug environment may simulate setting or resetting of input lines. The CO4012 first scans the physical input lines and then processes the scanned values with the debug parameters.

Index 5001 and 5002 make direct bit manipulation of single bits possible.

Index 5001 enables bit setting by using a bit wise logical OR conjunction with index 6000 while index 5002 performs a logical AND conjunction with index 6000 and therefore enables resetting of single bits.

Objects 5001 and 5002 are always working in continuous execution mode. This means that logical operations with object 6000 are performed in each internal input scan cycle

Index	5001h (5002h)
Name	Write 1 to digital input (Write 0 to digital input)
Description	-
Data Type	Array

Index	Sub-Index 0
Name	
Description	Number of mapped objects
Data Type	Unsigned 8
Access modes	RO
PDO Mapping	NO
Value Range	-
Default Value	Number of digital input bytes

Index	Sub-Index 1 to Nr of input bytes
Name	
Description	Bitmap to mask input byte with
Data Type	Unsigned 8
Access modes	RW
PDO Mapping	YES
Value Range	-
Default Value	0 for 5001 (0FFh for 5002)

Index 5003 : Filter Time Digital Input

The CO4012A offers noise filtering for each digital input line. With object 5003 an individual filter time may be assigned to each input line.

The filtering function enable object is at index 6003h. The filter time is set in milliseconds. A value of 0 disables the filtering function.

Index	5003h
Name	Filter Time Digital Input
Description	-
Data Type	Array

Index	Sub-Index 0
Name	Nr of Subobjects
Description	
Data Type	Unsigned 8
Access modes	RO
PDO Mapping	No
Value Range	-
Default Value	Number of digital input lines

Index	Sub-Index 1 to Nr of input lines
Name	Filter Time
Description	There is a individual Time for each input line.
Data Type	Unsigned 8
Access modes	RW
PDO Mapping	No
Value Range	-
Default Value	5

Index 6000 : Read Digital Input 8 Bit

This object represents the digital input bytes. The value of the input lines is written to this object.

Before writing the level of the input lines to object 6000, the input data is processed in the following way:

- 1) The digital input lines are active low. This means, the input level is inverted at first.
- 2) At the next stage, the CO4012A processes the filtering function. Object 5003 gives the filtering time and object 6003 enables or disables the channels.
- 3) Then the input lines are inverted again according to the setting of object 6002h (polarity input)
- 4) At last the debug function calculates a logical OR conjunction between the input lines and object 5001 and a logical AND with object 5002 and then writes the result to object 6000h

The number of digital input bytes depends on the selected operation mode.

The mapping of the I/O lines to object 6000 is explained in chapter "Mapping I/O to Object Dictionary"

Index	6000h
Name	Digital Input 8 Bit
Description	-
Data Type	Array

Index	Sub-Index 0
Name	Nr of Subobjects
Description	
Data Type	Unsigned 8
Access modes	RO
PDO Mapping	No
Value Range	-
Default Value	Number of digital input bytes

Index	Sub-Index 1 to Nr of input bytes
Name	Digital Input 8 Bit Byte n
Description	
Data Type	Unsigned 8
Access modes	RO
PDO Mapping	Yes
Value Range	-
Default Value	-

Index 6002 : Polarity Input 8 Bit

With this object, the digital inputs may be inverted. See also Index 6000 for additional information. The number of digital input bytes depends on the selected operation mode.

Index	6002h
Name	Polarity Input 8 Bit
Description	-
Data Type	Array

Index	Sub-Index 0
Name	Nr of Subobjects
Description	
Data Type	Unsigned 8
Access modes	RO
PDO Mapping	No
Value Range	-
Default Value	Number of digital input bytes

Index	Sub-Index 1 to Nr of input bytes
Name	Polarity Input 8 Bit Byte n
Description	
Data Type	Unsigned 8
Access modes	RW
PDO Mapping	No
Value Range	-
Default Value	0

Index 6003 : Filter Enable Input 8 Bit

With this object, the additional input filtering may be enabled individual for each input. 0 at the input line corresponding bit position means filter is disabled. See also Index 5003. The number of digital input bytes depends on the selected operation mode.

Index	6002h
Name	Polarity Input 8 Bit
Description	-
Data Type	Array

Index	Sub-Index 0
Name	Nr of Subobjects
Description	
Data Type	Unsigned 8
Access modes	RO
PDO Mapping	No
Value Range	-
Default Value	Number of digital input bytes

Index	Sub-Index 1 to Nr of input bytes
Name	Polarity Input 8 Bit Byte n
Description	
Data Type	Unsigned 8
Access modes	RW
PDO Mapping	No
Value Range	-
Default Value	0

Index 6005 : Global Interrupt Enable

This object enables or disables globally the interrupt behaviour without changing the interrupt masks. In event-driven mode the device transmits the input values depending on the interrupt masks in objects 6006h, 6007h, and 6008h and the PDO transmission type.

TRUE (1)= global interrupt enabled
FALSE (0)= global interrupt disabled

Index	6005h
Name	Global Interrupt Enable
Description	-
Data Type	Boolean
Access modes	RW
PDO Mapping	No
Value Range	-
Default Value	TRUE

Index 6006 : Interrupt Mask Any Change

This object determines, which input lines shall activate an interrupt by any change of the input line. Both negative and positive edge will cause an interrupt, if enabled.

An interrupt will cause a PDO transmission in case of event driven transmission mode.

- 1 = interrupt enabled
- 0 = interrupt disabled

Index	6006h
Name	Interrupt Mask any change
Description	-
Data Type	Array

Index	Sub-Index 0
Name	Nr of Subobjects
Description	
Data Type	Unsigned 8
Access modes	RO
PDO Mapping	No
Value Range	-
Default Value	Number of digital input bytes

Index	Sub-Index 1 to Nr of input bytes
Name	Interrupt Mask any change
Description	
Data Type	Unsigned 8
Access modes	RW
PDO Mapping	No
Value Range	-
Default Value	0FFh (interrupt enabled)

Index 6007 : Interrupt Mask Low to High

This object has the same structure and behaviour as object 6006h but will cause interrupts only on rising edge of object index 6000. Note that input lines are active low, so rising edge of input data (object 6000) means falling edge of input port line.

Default value is 0.

Index 6008 : Interrupt Mask High to Low

This object has the same structure and behaviour as object 6006h but will cause interrupts only on falling edge of object index 6000. Note that input lines are active low, so falling edge of input data (object 6000) means rising edge of input port line.

Default value is 0.

DS401: Digital Output Objects

The following objects are describing the functionality of the digital output lines of the CO4012A. The CO4012A supports only 8bit access.

The number of digital output bytes depends on the selected operation mode.

Index 6200 : Write to Digital Output

With object 6200, the digital outputs of the CO4012A can be written to. Before writing to the output ports, the value of the bitmap of object 6200 is processed with object 6202 (Change polarity output 8 bit) and the inverted. (Output port bits of the CO4012A device are active low)

The mapping of the I/O lines to object 6200 is explained in chapter "Mapping I/O to Object Dictionary"

Index	6200h
Name	Write to digital output
Description	-
Data Type	Array

Index	Sub-Index 0
Name	
Description	Number of mapped objects
Data Type	Unsigned 8
Access modes	RO
PDO Mapping	NO
Value Range	-
Default Value	Number of digital output bytes

Index	Sub-Index 1 to Nr of output bytes
Name	Write to digital output
Description	
Data Type	Unsigned 8
Access modes	WO
PDO Mapping	YES
Value Range	-
Default Value	0

Index 6202 : Polarity Output 8 Bit

With this object, the digital outputs may be inverted.
See also Index 6200 for additional information.

Index	6202h
Name	Polarity Output 8 Bit
Description	-
Data Type	Array

Index	Sub-Index 0
Name	Nr of Subobjects
Description	
Data Type	Unsigned 8
Access modes	RO
PDO Mapping	No
Value Range	-
Default Value	Number of digital output bytes

Index	Sub-Index 1 to Nr of input bytes
Name	Polarity Output 8 Bit Byte n
Description	
Data Type	Unsigned 8
Access modes	RW
PDO Mapping	No
Value Range	-
Default Value	0

Index 6206 : Error Mode Output 8 Bit

This object indicates, whether an output is forced to a predefined value (given in object 6207) in case of a device error.

- 1 = Output will be forced to the value selected in object 6207
0 = Output will be unchanged even in case of an error condition.

Index	6206h
Name	Error Mode Output 8 Bit
Description	-
Data Type	Array

Index	Sub-Index 0
Name	Nr of Subobjects
Description	
Data Type	Unsigned 8
Access modes	RO
PDO Mapping	No
Value Range	-
Default Value	Number of digital output bytes

Index	Sub-Index 1 to Nr of input bytes
Name	Error Mode Output 8 Bit Byte n
Description	
Data Type	Unsigned 8
Access modes	RW
PDO Mapping	No
Value Range	-
Default Value	0FFh (Take error condition from object 6207)

Index 6207 : Error Value Output 8 Bit

This object selects the level the outputs are forced to in case of device error mode if the error mode (object 6206 is enabled)

- 1 = Output will be forced to active state
0 = Output will be forced to inactive state.
Note: Outputs of CO4012 are active low.

Index	6207h
Name	Error Value Output 8 Bit
Description	-
Data Type	Array

Index	Sub-Index 0
Name	Nr of Subobjects
Description	
Data Type	Unsigned 8
Access modes	RO
PDO Mapping	No
Value Range	-
Default Value	Number of digital output bytes

Index	Sub-Index 1 to Nr of input bytes
Name	Error Value Output 8 Bit Byte n
Description	
Data Type	Unsigned 8
Access modes	RW
PDO Mapping	No
Value Range	-
Default Value	0 (Inactive, high level)

DS401: Analog Input Objects

The following objects are describing the functionality of the analog input lines of the CO4012A.

The number of analog input bytes depends on the selected operation mode.

Index 6400 : Read Analog Input 8 Bit

Object 6400, represents the value of the analog channels. The 8 bit conversion result of the analog input voltage is a signed value. Therefore voltages less than 2.5V are read as negative input voltage. An input of 2.5V is read as 0 and an input voltage higher than 2.5V is converted into positive values.

If the application requires reading of the analog input voltage as unsigned values, the object 6431 may be used for adding an offset to the conversion result.

The mapping of the I/O lines to object 6400 is explained in chapter "Mapping I/O to Object Dictionary"

Note:

Object 6400 is only valid if operation mode selects 8 Bit resolution of A/D converter.

Index	6400h
Name	Read Analog Input
Description	-
Data Type	Array

Index	Sub-Index 0
Name	
Description	Number of mapped objects
Data Type	Unsigned 8
Access modes	RO
PDO Mapping	NO
Value Range	-
Default Value	Number of analog input bytes

Index	Sub-Index 1 to Nr of input lines
Name	Read Analog Input
Description	
Data Type	Signed 8
Access modes	RO
PDO Mapping	YES
Value Range	-
Default Value	-

Index 6401 : Read Analog Input 16 Bit

Object 6401, represents the value of the analog channels. The 16 bit conversion result of the analog input voltage is a signed value. Therefore voltages less than 2.5V are read as negative input voltage. An input of 2.5V is read as 0 and an input voltage higher than 2.5V is converted into positive values.

If the application requires reading of the analog input voltage as unsigned values, the object 6431 may be used for adding an offset to the conversion result.

The mapping of the I/O lines to object 6401 is explained in chapter "Mapping I/O to Object Dictionary"

Note:

Object 6401 is only valid if operation mode selects 16 Bit resolution of A/D converter.

Index	6401h
Name	Read Analog Input
Description	-
Data Type	Array

Index	Sub-Index 0
Name	
Description	Number of mapped objects
Data Type	Unsigned 8
Access modes	RO
PDO Mapping	NO
Value Range	-
Default Value	Number of analog input bytes

Index	Sub-Index 1 to Nr of input lines
Name	Read Analog Input
Description	
Data Type	Signed 16
Access modes	RO
PDO Mapping	YES
Value Range	-
Default Value	-

Index 6421 : Analog Input Interrupt Trigger

Object 6421 selects the event that shall cause a transmission interrupt for the selected analog channel.

There is one Sub-Index for each channel to enable individual setting according to application requirements.

Table of possible Trigger Conditions:

Bit Nr	Interrupt Trigger Selection
0	Input voltage greater than Upper Limit
1	Input voltage less than Lower Limit
2	Input changed by more than Delta
3	Input reduced more than Negative Delta
4	Input increased more than Positive Delta
5 to 7	Reserved (must be forced to zero)

Index	6421h
Name	Analog Input Interrupt Trigger
Description	-
Data Type	Array

Index	Sub-Index 0
Name	
Description	Number of mapped objects
Data Type	Unsigned 8
Access modes	RO
PDO Mapping	NO
Value Range	-
Default Value	Number of analog input lines

Index	Sub-Index 1 to Nr of input lines
Name	Analog Input Interrupt Trigger
Description	Selects trigger condition
Data Type	Unsigned 8 (See Table of Trigger Conditions)
Access modes	RW
PDO Mapping	No
Value Range	-
Default Value	7

Index 6423 : Analog Input Interrupt Enable

This object enables or disables globally the interrupt behaviour without changing the interrupt masks. The interrupt is disabled by default, in order to avoid transmission of analog input values.

TRUE (1)= global interrupt enabled
FALSE (0)= global interrupt disabled

Index	6423h
Name	Analog Input Interrupt Enable
Description	-
Data Type	Boolean
Access modes	RW
PDO Mapping	No
Value Range	-
Default Value	FALSE

**Index 6424/5/6/7/8 :
Analog Input Interrupt Limits**

These objects give the Limit for generation of interrupts. All objects have the same structure. The function of the interrupt limit is only enabled, if the corresponding bit of object 6421 is set. All values of limit parameters are signed 32. So the user must take care not to exceed the range of the input data objects.

Table of Limit Function

Object	Object Name and Function
6424	Analog Input Upper Limit Generate interrupt if input voltage is greater than Upper Limit (6424)
6425	Analog Input Lower Limit Generate interrupt if input voltage is less than Lower Limit (6425)
6426	Analog Input Interrupt Delta Generate interrupt if input voltage changed by more than Interrupt Delta
6427	Analog Input Negative Delta Generate interrupt if input voltage reduced by more than Negative Delta
6428	Analog Input Positive Delta Generate interrupt if input voltage increased by more than Positive Delta

Index	6424/5/6/7/8/9
Name	See table above
Description	-
Data Type	Array

Index	Sub-Index 0
Name	
Description	Number of mapped objects
Data Type	Unsigned 8
Access modes	RO
PDO Mapping	NO
Value Range	-
Default Value	Number of analog input lines

Index	Sub-Index 1 to Nr of input lines
Name	See table above
Description	
Data Type	Integer 32
Access modes	RW
PDO Mapping	No
Value Range	-
Default Value	0

Index 6431 : Analog Input Offset

Object 6431 adds an offset value to the analog input data object (6400 / 6401).

The normal input scaling for analog data objects 6400 and 6401 considers conversion of negative input voltages (input amplifier must shift to positive voltages because input port pin is 0 to 5V only) by placing the zero point (of data) to 2.5V. (middle of input voltage range)

If application requires only positive input values an offset may be add with object 6431, in order to adjust the zero point for data to an input voltage of 0V. For 8 Bit analog conversion (object 6400) the offset value (object 6431) must be 80h. For 16 Bit analog conversion (object 6401) the offset value must be set to 8000h.

Index	6431h
Name	Analog Input Offset
Description	-
Data Type	Array

Index	Sub-Index 0
Name	
Description	Number of mapped objects
Data Type	Unsigned 8
Access modes	RO
PDO Mapping	NO
Value Range	-
Default Value	Number of analog input lines

Index	Sub-Index 1 to Nr of input lines
Name	Analog Input Offset
Description	
Data Type	Signed 32
Access modes	RW
PDO Mapping	No
Value Range	-
Default Value	0

Power Down Control Objects

For control of the Power-Down-Mode 6 objects are applied in the object dictionary of the CO4012.

Index 2FFA : Wake-Up-Confirm-Time

Wake-Up-Confirm-Time

The CO4012 switches to the active run mode after a wake up event by pin WUII (Wake-Up-Interrupt-Input).

If it doesn't receive a valid NMT telegram during the Wake-Up-Confirm-Time, so it automatically switches back to the Power-Down-Mode.

The time is given in milliseconds.

The access is done by SDO.

Index	2FFA
Name	Wake-Up-Confirm-Time
Description	-
Data Type	Unsigned 16
Access modes	RW
PDO Mapping	NO
Value Range	200 .. 20000
Default Value	1000

Index 2FFB : Power-Down-Delay-Time

Power-Down-Delay-Time

After reception of Power-Down instruction the CO4012 waits for the period Power-Down Delay Time and than switches over in Power-Down-Mode.

The time is given in milliseconds.

The access is done by SDO.

Index	2FFB
Name	Power-Down-Delay-Time
Description	-
Data Type	Unsigned 16
Access modes	RW
PDO Mapping	NO
Value Range	0 .. 20000
Default Value	500

Index 2FFC : Wake-Up-Counter

Wake-Up-Counter

The Wake Up Counter counts all wake up events of Power-Down-Mode. The access to the counter is done by SDO.

Index	2FFC
Name	Wake-Up-Counter
Description	-
Data Type	Unsigned 32
Access modes	RW
PDO Mapping	YES
Value Range	-
Default Value	0

Index 2FFD : Reset Power Down Input Pin Enable

Enable "Reset Power Down Input"

Reset Power Down Input is configured by writing the value 0x5250454E ("RPEN") to this object. As soon as this signature will be written pin1 (IN9) is used as Reset Power Down Input (RPDI). Then it cannot be used as digital input line any more.

Index	2FFD
Name	Reset Power Down Input Enable
Description	-
Data Type	Unsigned 32
Access modes	RW
PDO Mapping	NO
Value Range	-
Default Value	0

Index 2FFE : Power-Down-Enable**Power-Down-Enable**

The use of Power-Down-Mode is enabled by writing the value 0x5044454E ("PDEN") to this object. As soon as this signature will be written, pin2 (IN8) is configured as Wake-Up-Interrupt-Input (WUII). Then it cannot be used as digital input pin any more. The correct signature is the requirement for acceptance of all further power down instructions.

Index	2FFE
Name	Power-Down-Enable
Description	-
Data Type	Unsigned 32
Access modes	RW
PDO Mapping	NO
Value Range	-
Default Value	0

Index 2FFF : Switch-To-Power-Down-Mode**Switch-To-Power-Down-Mode**

Setting the value 0x504F4646 ("POFF") (see above) will force the device to power down mode. After receiving the Switch-To-Power-Down-Mode command, the chip will continue working for the Power-Down-Delay-Time and then will enter power down mode.

The correct signature in object 2FFE is the requirement for acceptance of the Switch-To-Power-Down-Mode instruction.

Index	2FFF
Name	Switch To Power Down Mode
Description	-
Data Type	Unsigned 32
Access modes	WO
PDO Mapping	NO
Value Range	-
Default Value	0

Mapping I/O to Object Dictionary

The mapping of the I/O channels depends on the setting of configuration bits CFG0 to CFG2. All possible configurations are shown in individual tables. Select the table for your application according to I/O requirements.

Note for A/D converter the maximum resolution is 10 bit. Tables that show analog input with 16-bit mean, that dictionary entry is made as signed integer (16 bit wide).

Summary of operation modes

The following table shows a summary of possible operation modes.

3	CFG			Mode	Description
	2	1	0		
X	1	1	1	0	16 digital In / 16 dig. Out
X	1	1	0	1	32 digital In
X	1	0	1	2	32 digital Out
X	1	0	0	3	8 analog In 16 bit
X	0	x	X	4	Reserved *1)
	x	X	X		Reserved *1)

*1) These modes are reserved for future use and must not be set. Selecting the reserved modes may cause improper operation of the device.

The selected operation mode may be read via object 2101h from the object dictionary.

Note:

Setting of configuration must be fixed. The CO4012 scans the setting of CFG0 to CFG3 only during reset. Changing of configuration on the fly is not allowed and may cause improper operation of the device.

Note that configuration pins are input during reset but may be switched to output during operation. See Pin Description for additional information.

16 digital in / 16 digital out

Operation mode 0 CFG 2 = 1 CFG1 = 1 CFG0 = 1 EDS-file: CO4012A0.EDS Supported PDOs: 2 Transmit-PDOs (TPDO1 and TPDO2) 1 Receive-PDO								
Data Mapping to Dictionary								
Index. Sub-Index	Mapped I/O Signal bit/value							
	7	6	5	4	3	2	1	0
6000.01	IN7 to IN0							
6000.02	IN15 to IN8							
6200.01	OUT7 to OUT0							
6200.02	OUT15 to OUT8							
Default PDO Mapping								
PDO	Mapped Data							
RPDO1	6200.01 digital output OUT0 to 7 6200.02 digital output OUT8 to 15							
TPDO1	6000.01 digital input IN0 to IN7 6000.02 digital input IN8 to IN15							

32 digital in

Operation mode 1 CFG 2 = 1 CFG1 = 1 CFG0 = 0 EDS-file: CO4012A1.EDS Supported PDOs: 2 Transmit-PDOs (TPDO1 and TPDO2) Receive-PDO1								
Data Mapping to Dictionary								
Index. Sub-Index	Mapped I/O Signal bit/value							
	7	6	5	4	3	2	1	0
6000.01	IN7 to IN0							
6000.02	IN15 to IN8							
6000.03	IN23 to IN16							
6000.04	IN31 to IN24							
Default PDO Mapping								
PDO	Mapped Data							
TPDO1	6000.01 digital input IN0 to IN7 6000.02 digital input IN8 to IN15 6000.03 digital input IN16 to IN23 6000.04 digital input IN24 to IN31							

32 digital Out

Operation mode 2 CFG 2 = 1 CFG1 = 0 CFG0 = 1 EDS-file: CO4012A2.EDS Supported PDOs: 1 Receive-PDO	
Data Mapping to Dictionary	
Index. Sub-Index	Mapped I/O Signal bit/value
	7 6 5 4 3 2 1 0
6200.01	OUT7 to OUT0
6200.02	OUT15 to OUT8
6200.03	OUT23 to OUT16
6200.04	OUT31 to OUT24
Default PDO Mapping	
PDO	Mapped Data
RPDO1	6200.01 digital out OUT0 to 7 6200.02 digital out OUT8 to 15 6200.03 digital out OUT16 to 23 6200.04 digital out OUT24 to 31

Note :

In operation mode 3 the first transmit PDO (TPDO1) is not implemented. The analog input objects are mapped to TPDO2 and TPDO3

8 analog In 16 bit

Operation mode 3 CFG 2 = 1 CFG1 = 0 CFG0 = 0 EDS-file: CO4012A3.EDS Supported PDOs: 2 Transmit-PDOs (TPDO2 and TPDO3)	
Data Mapping to Dictionary	
Index. Sub-Index	Mapped I/O Signal bit/value
	7 6 5 4 3 2 1 0
6401.01	Conversion result IN0 (16 bit)
6401.02	Conversion result IN1 (16 bit)
6401.03	Conversion result IN2 (16 bit)
6401.04	Conversion result IN3 (16 bit)
6401.05	Conversion result IN4 (16 bit)
6401.06	Conversion result IN5 (16 bit)
6401.07	Conversion result IN6 (16 bit)
6401.08	Conversion result IN7 (16 bit)
Default PDO Mapping	
PDO	Mapped Data
TPDO1	Not implemented !!
TPDO2	6401.01 analog input IN0 (16 bit) 6401.02 analog input IN1 (16 bit) 6401.03 analog input IN2 (16 bit) 6401.04 analog input IN3 (16 bit)
TPDO3	6401.05 analog input IN4 (16 bit) 6401.06 analog input IN5 (16 bit) 6401.07 analog input IN6 (16 bit) 6401.08 analog input IN7 (16 bit)

Emergency Messages

The CO4012 supports several emergency messages. For all emergencies the same structure is used:

Byte								
0	1	2	3	4	5	6	7	
EMY-Code	1001	0	CO4012-Code					

EMY-Code: Emergency-Error-Code according to DS301

1001: Content of Object 1001

CO4012-Code: Emergency-Error-Code for CO4012 as unsigned 32 value

CO4012-Code (hex)	May change		Description
	NMT	I/O	
8000 0000	X	X	CAN bus is bus off
4000 0000			CAN bus in error warning state
2000 0000			Node guarding warning
3000 0000	X	X	Life guarding error
0000 0001	X	X	Output Overload detected
0000 0100			Wake up from Power down

Emergency 2000 0000 (Node guarding warning) must be enabled with object 2103.

If more than one error is active at the same time, the bitmap of the CO4012-Codes for all active errors are combined with a logical or conjunction.

In case of more than one existing emergency condition at the same time. The EMY-Code of the emergency message always shows the code for the emergency with the highest priority without taking care of the time the emergency events occurred.

The priorities are sorted in the following order:

Priority	Emergency event
highest	CAN bus line: return from bus off or error warning
2	Node guarding or life guarding
3	Output overload
lowest	Wake up from power down

Some of the emergencies may cause a NMT state change and/or may force the output pins to the error state. This behaviour depends on the setting of object 1029.

The ID for emergency transmission is fixed to: 0x80 + \$NodeID.

List of emergency messages:

Life-Guarding Error							
30	81	01	00	00	00	00	30

This error occurs, if the masters fails to transmit the guarding remote frame within the specified Life Time (Guard Time object 100C multiplied with Life Time Factor object 100D)

Output Overload Error							
10	23	01	00	01	00	00	00

This error occurs, if the output overload interrupt input pin (OLIRQ# pin 60) is active low.

CAN Bus in Error Warning state							
00	81	01	00	00	00	00	40

This error occurs, if the chips internal CAN module is in error warning state.

Return from CAN Bus OFF							
40	81	11	00	00	00	00	C0

This message indicates a return from Bus OFF state.

Absolute Maximum Ratings

Stresses greater than those listed parameters may cause permanent damage to the device. Functional operation should be restricted to recommended operation conditions. Exposure to absolute maximum rating conditions for extended times may affect reliability.

Parameter	Symbol	Rated Value		Units	Remarks
		Min.	Max.		
Power supply voltage	VCC	VSS – 0.3	VSS + 6.0	V	
Analog power supply voltage	AVCC	VSS – 0.3	VCC	V	
Analog reference voltage	AVREF	VSS – 0.3	VCC	V	
Input voltage	Vi	VSS – 0.3	VSS + 6.0	V	Vi < VCC + 0.3V
Output voltage	Vo	VSS – 0.3	VSS + 6.0	V	Vo < VCC + 0.3V
L level maximum output current	IOLMAX		15	mA	Time < 20 msec
L level maximum output current	IOL		4	mA	
H level maximum output current	IOHMAX		15	mA	Time < 20 msec
H level maximum output current	IOH		4	mA	
Maximum Power dissipation	P _{MAX}		300	mW	
Operating temperature	T _A	-40	+85	°C	CO4012A
	T _A	-40	+105	°C	CO4012AE
Storing temperature	T _A	-55	+150	°C	

Recommended Operation Conditions and Characteristics

Functional operation should be restricted to recommended operation conditions.

Parameter	Symbol	Rated Value			Units	Remarks
		Min.	Typ.	Max.		
Power supply voltage	VCC	4.5	5.0	5.5	V	
Analog power supply voltage	AVCC			VCC	V	
Analog reference voltage	AVREF			VCC	V	
Power supply current	I _{CC}		35	50	mA	All inputs V _{IL} or V _{IH} All outputs open
Input H voltage	V _{IH}	0.8 * VCC		VCC + 0.3	V	
Input L voltage	V _{IL}	VSS – 0.3		0.2 * VCC	V	
Output H voltage	V _{OH}	VCC – 0.5			V	I _{OH} = -4.0 mA
Output L voltage	V _{OL}			0.4	V	I _{OL} = 4.0 mA
Input leakage current	I _{LKC}	-5		5	uA	
Crystal frequency	f _{osc}		4		MHz	
Reset pulse width	t _{res}	10			us	
Power on rise time	t _{RESLH}	0.05		30	ms	
Maximum CANopen Delay input pin to bus telegram	t _{DITB}	0.05	1	2	ms	No additional bus distribution delay
Maximum CANopen Delay bus telegram to output pin	t _{DBTO}	0.05	1	2	ms	
Watchdog trigger frequency	f _{WDT}	0.5	1	2	kHz	Delayed max. 500 ms after reset
Maximum Power dissipation	P _{MAX}			300	mW	
Operating temperature	T _A	-40		+85	°C	CO4012A
	T _A	-40		+105	°C	CO4012AE

Package Dimension CO4012A-FL

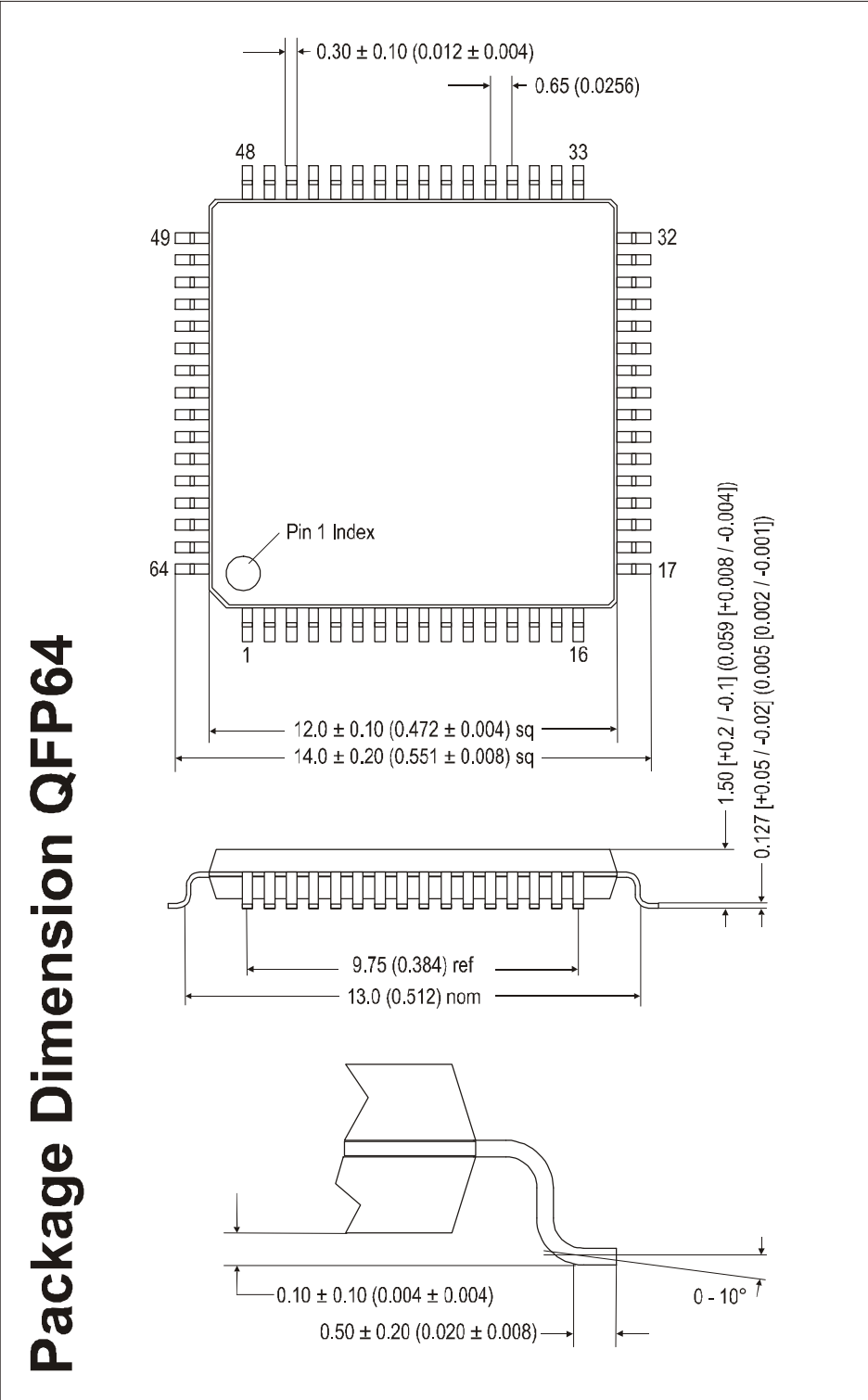

General Description	1	Index 1001 : Error Register	10
Features	1	Index 1002 : Status Register	10
Applications	1	Index 1005 : COB-ID Sync	10
CANopen Features	1	Index 1008 : Device Name	11
Ordering Information	1	Index 1009 : Hardware Version	11
Pin Assignment	2	Index 100B : Node-ID.....	11
Pin Listing	2	Index 100C : Guard Time.....	12
Pin Listing continued	2	Index 100D : Life Time Factor	12
Pin Description	2	Index 100E : COB-ID Guard.....	12
OUTx/INx and INx/OUTx: Digital I/O pins.....	2	Index 1010 : Store Parameters.....	12
IN0/OUT31 to IN7/OUT24: Digital I/O or analog input pins.....	3	Index 1011 : Restore Default Parameters	13
CF: Filter Capacitor input.....	3	Index 1014 : COB-ID Emergency.....	13
X0, X1: Crystal oscillator input	3	Index 1015 : Inhibit Time Emergency.....	14
TEST: Reserved pin.....	3	Index 1017 : Producer Heartbeat Time	14
OLIRQ#: Output Overload Interrupt	3	Index 1018 : Identity Object.....	14
VCC, AVCC, VSS, AVSS: Power Supply Pins.....	3	Index 2000 : Device Manufacturer	15
RES#: Reset input pin.....	3	Index 2100 : New Node ID	15
CFG0 to CFG2: Configuration input pins.....	3	Index 2101 : System Configuration	15
CFG3/WD: Configuration input / watchdog output	3	Index 2110 : Enable Boot Up Message.....	15
CANRX, CANTX: CAN interface pins.....	3	Index 2180 : CAN Restart Time.....	15
Handling the Device	3	DS301: PDO Parameter Objects	16
Preventing latch up	3	Communication Parameter Objects	16
Handling unused Pins	4	PDO Mapping Objects	17
Power Supply Pins.....	4	DS401: Digital Input Objects	18
Power Supply for A/D converter.....	4	Index 5001/2 : Write to Digital Input	18
Input / output pins	4	Index 5003 : Filter Time Digital Input.....	19
Pull up/down resistors	4	Index 6000 : Read Digital Input 8 Bit.....	19
In Circuit programming of MB90F497	4	Index 6002 : Polarity Input 8 Bit.....	20
Device Configuration	5	Index 6003 : Filter Enable Input 8 Bit	20
CAN Identifier	5	Index 6005 : Global Interrupt Enable.....	20
Baud rate.....	5	Index 6006 : Interrupt Mask Any Change	21
Operation Mode Selection	5	Index 6007 : Interrupt Mask Low to High.....	21
Enable additional CAN features.....	5	Index 6008 : Interrupt Mask High to Low.....	21
Power Down Mode	6	DS401: Digital Output Objects	21
Activate Power-Down.....	6	Index 6200 : Write to Digital Output	21
Return from Power-Down	6	Index 6202 : Polarity Output 8 Bit	22
Emergency-Message	6	Index 6206 : Error Mode Output 8 Bit.....	22
Object Dictionary	7	Index 6207 : Error Value Output 8 Bit	22
DS301: global Objects.....	7	DS401: Analog Input Objects	23
DS301: PDO Parameter Objects	8	Index 6400 : Read Analog Input 8 Bit.....	23
DS401: Digital Input Objects.....	8	Index 6401 : Read Analog Input 16 Bit.....	23
DS401: Digital Output Objects	9	Index 6421 : Analog Input Interrupt Trigger	24
DS401: Analog Input Objects	9	Index 6423 : Analog Input Interrupt Enable	24
Additional Objects for Power Down.....	9	Index 6424/5/6/7/8 : Analog Input Interrupt Limits.....	25
Description of Object Dictionary	9	Index 6431 : Analog Input Offset	25
Index 0005.....	9	Power Down Control Objects	26
Index 0006.....	9	Index 2FFA : Wake-Up-Confirm-Time.....	26
Index 0007.....	9	Index 2FFB : Power-Down-Delay-Time.....	26
DS301: Global Objects	10	Index 2FFC : Wake-Up-Counter	26
Index 1000 : Device Type.....	10	Index 2FFD : Reset Power Down Input Pin Enable..	26
		Index 2FFE : Power-Down-Enable.....	27
		Index 2FFF : Switch-To-Power-Down-Mode.....	27
		Mapping I/O to Object Dictionary	28
		Summary of operation modes.....	28
		16 digital in / 16 digital out.....	28
		32 digital in	28
		32 digital Out	29

8 analog In 16 bit	29
Emergency Messages.....	30
Absolute Maximum Ratings.....	31
Recommended Operation Conditions and Characteristics.....	31
Package Dimension CO4012A-FL.....	32