

### Allgemein

Das hipecs-CIO101 ist ein kostengünstiges CANopen Relaismodul und verfügt über 8 Relais. Vier davon als Schließer und vier als Wechsler. Die Nennschaltspannung beträgt hierbei 240 Volt AC bei einem Dauerstrom von 5 Ampere.

In diesem E/A-Modul sind die komplexen CANopen-Standards DS301 und DS401 implementiert. Alle üblichen Baudraten bis zu 1 Mbit werden unterstützt.

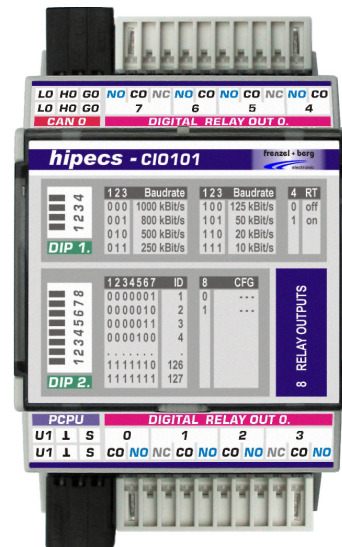

### Funktionen

- CANopen remote I/O Modul entsprechend den CiA Draft Standards DS301 Version 4.0 und DS401 Version 2.0
- 8 Relais, davon 4 Schließer und 4 Wechsler
- Nennschaltspannung 240 VAC
- maximale Schaltspannung 400 VAC
- Dauerstrom 5 Ampere
- CAN-Baudraten bis 1Mbit
- CAN-Bus ISO11898 mit Transceiver TJA1050
- 4 Transmit und 4 Receive PDOs
- Dynamisches PDO Mapping
- Variable PDO Identifier
- CANopen PDO Übertragungsmodi: synchron, asynchron, ereignisgesteuert, zyklisch, azyklisch und Remote Frame bezogen.
- Event Timer und Inhibit Timer für alle Transmit PDOs.
- Nodeguarding, Lifeguarding und Heartbeat
- Emergency Nachrichten
- Minimum boot up
- Kunststoffgehäuse zum Aufrasten auf DIN-Trageschienen
- Betriebstemperatur 0 bis 55 °C (opt. -40...+70 °C)



### Bestellinformation

Bauteil	Bestellnummer
hipecs-CIO101-i	EZ00000.2202.00
8 Relais, CAN galvanisch entkoppelt, 0...+55 °C	
hipecs-CIO101-ie	EZ00000.3101.00
8 Relais, CAN galvanisch entkoppelt, -40...+70 °C	

### Technische Daten

Spannungsversorgung System	Min.	Norm.	Max.
Nominale System/Bus Versorgungsspannung	11 V	24 V	32 V
Stromaufnahme System / Bus, alle Relais aktiv	90 mA (Vcc = 32 V)	110 mA	230 mA (Vcc = 11 V)
CAN bus Norm	ISO11898		
CiA Draft Standards	DS301 Version 4.0 und DS401 Version 2.0		
Konformitätserklärung	CE		

Relais	
Anzahl Relais	8
Schaltverhalten	4 x Schließer / 4 x Wechsler
Isolation CAN-Bus zum System	60 V
Isolation Relaiskontakte zum System	500 V
CAN-Verzögerungszeit ( CAN reaction time )	2 ms ( typisch < 1ms)
Ansprechzeit Relais	5 ms
Rückfallzeit Relais	2,5 ms
Nennschaltspannung	240 VAC
max. Schaltspannung	400 VAC
max. Dauerstrom	5 A
minimale Last für Kontakte	100 mA / 12 V
Nennschaltfrequenz mit / ohne Last	6 / 1200 min <sup>-1</sup>
mechanische Lebensdauer	10 x 10 <sup>6</sup>
elektrische Lebensdauer 3A / 250 VAC / 85°C / 6 Schalvorgänge/Min.	100 x 10 <sup>3</sup>
elektrische Lebensdauer 5A / 250 VAC / 85°C / 6 Schalvorgänge/Min.	10 x 10 <sup>3</sup>

Stecker und Abmessungen	
Versorgungs- und CAN-Stecker	
Stecker	WAGO Steckverbinder Typ 713
Leitungsquerschnitt [mm <sup>2</sup> ]	0,08 bis 1,5 mm <sup>2</sup>
Leitungsquerschnitt [AWG]	14 bis 28 AWG
Abisolierlänge	7 mm
Relaisstecker	
Stecker	WAGO Steckverbinder Typ 734
Leitungsquerschnitt [mm <sup>2</sup> ]	0,08 bis 1,5 mm <sup>2</sup>
Leitungsquerschnitt [AWG]	14 bis 28 AWG
Abisolierlänge	7 mm
Abmessungen CIO101 Gehäuse	ca. 125 x 90 x 62 mm (Bild "Abmessungen" beachten!)
Betriebstemperatur	0 .. 55°C (opt. -40...+70°C)

### Steckerbelegung X1 ( CAN )

Pin Nr.	Name	Funktion
1	G0	CAN Ground
2	G0	CAN Ground
3	H0	CAN High Signal
4	H0	CAN High Signal
5	L0	CAN Low Signal
6	L0	CAN Low Signal

### Steckerbelegung X2 (Relay Out 0.x)

Pin Nr.	Name	Funktion
1	R4 CO	Common
2	R4 NO	Arbeitskontakt / Schließer
3	R5 NC	Ruhekontakt
4	R5 CO	Wechselkontakt / Common
5	R5 NO	Arbeitskontakt
6	R6 CO	Common
7	R6 NO	Arbeitskontakt / Schließer
8	R7 NC	Ruhekontakt
9	R7 CO	Wechselkontakt / Common
10	R7 NO	Arbeitskontakt

### Steckerbelegung X3 (Versorgung)

Pin Nr.	Name	Funktion
1	U1	Versorgungsspannung DC 24V für System / Bus
2	U1	Versorgungsspannung DC 24V für System / Bus
3	GND	Masse für System / Bus
4	GND	Masse für System / Bus
5	S	Schutzleiter
6	S	Schutzleiter

### Steckerbelegung X4 (Relay Out 0.x)

Pin Nr.	Name	Funktion
1	R0 CO	Common
2	R0 NO	Arbeitskontakt / Schließer
3	R1 NC	Ruhekontakt
4	R1 CO	Wechselkontakt / Common
5	R1 NO	Arbeitskontakt
6	R2 CO	Common
7	R2 NO	Arbeitskontakt / Schließer
8	R3 NC	Ruhekontakt
9	R3 CO	Wechselkontakt / Common
10	R3 NO	Arbeitskontakt

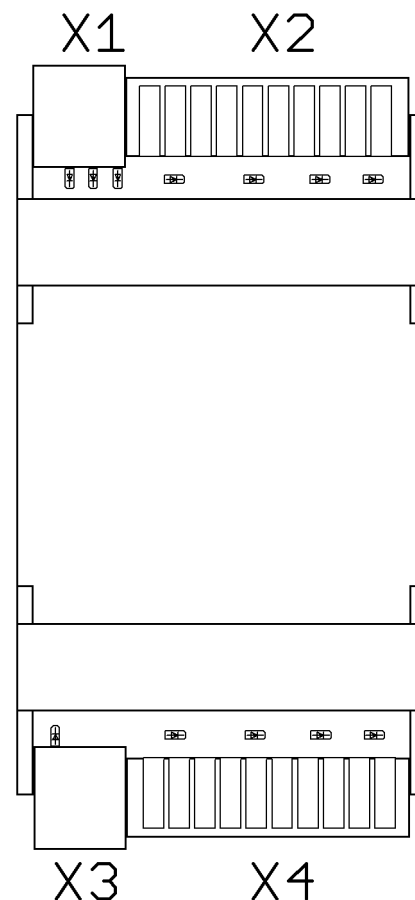

Ansicht von oben

### Konfiguration Dip-Schalter DIP1 und DIP2

DIP Switch SW1 (Einstellung Baurate)				
Switch Nummer				Funktion
1	2	3	4	
BD2	BD1	BD0	RT	
X	X	X	ON	CAN-Terminierung ein
X	X	X	OFF	CAN-Terminierung aus
OFF	OFF	OFF	X	1 Mbit / sec
OFF	OFF	ON	X	800 kbit / sec
OFF	ON	OFF	X	500 kbit / sec
OFF	ON	ON	X	250 kbit / sec
ON	OFF	OFF	X	125 kbit / sec
ON	OFF	ON	X	50 kbit / sec
ON	ON	OFF	X	20 kbit / sec
ON	ON	ON	X	reserviert

DIP Switch SW2 (Einstellung Knotennummer)								
Switch Nummer								Funktion
1	2	3	4	5	6	7	8	
0	0	0	0	0	0	1	X	Node ID = 1
0	0	0	0	0	1	0	X	Node ID = 2
0	0	0	0	0	1	1	X	Node ID = 3
0	0	0	0	1	0	0	X	Node ID = 4
.	.	.	.	.	.	.	X	....
1	1	1	1	1	1	0	X	Node ID = 126
1	1	1	1	1	1	1	X	Node ID = 127
X	X	X	X	X	X	X	ON	Konfiguration (reserviert)
X	X	X	X	X	X	X	OFF	Konfiguration (reserviert)

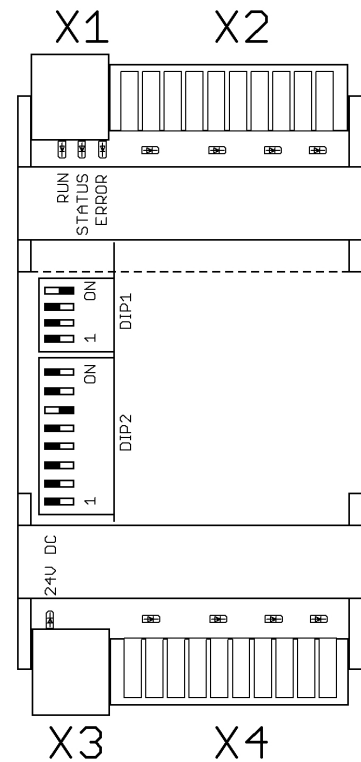

Ansicht von oben (Deckel geöffnet)

### CAN Signal LED's

LED	Farbe	Funktion
RUN-LED	grün	Die RUN-LED zeigt den NMT-Zustand entsprechend DRP303-3 an aus Betriebsspannung fehlt oder Defekt flackern CAN noch nicht gestartet 1x flashen Stopped (kurzes Aufblitzen) blinken Preoperational ein Operational
ERROR-LED	rot	Die Error-LED zeigt den Fehlerzustand entsprechend DRP303-3 an aus Kein Fehler 1x flashen CAN-Modul ist im Error-Warning-Zustand 2x flashen Node-Guarding-Fehler ein Bus-Off-Zustand des Knoten
STATUS-LED	gelb	Die gelbe Status LED zeigt weitere Fehler an 3x flashen noch keine boot-up Nachricht gesendet blinken unkritischer Fehler / kein NMT-Wechsel an kritischer Fehler / NMT state gewechselt

### Prinzipschaltbild Relaisbeschaltung

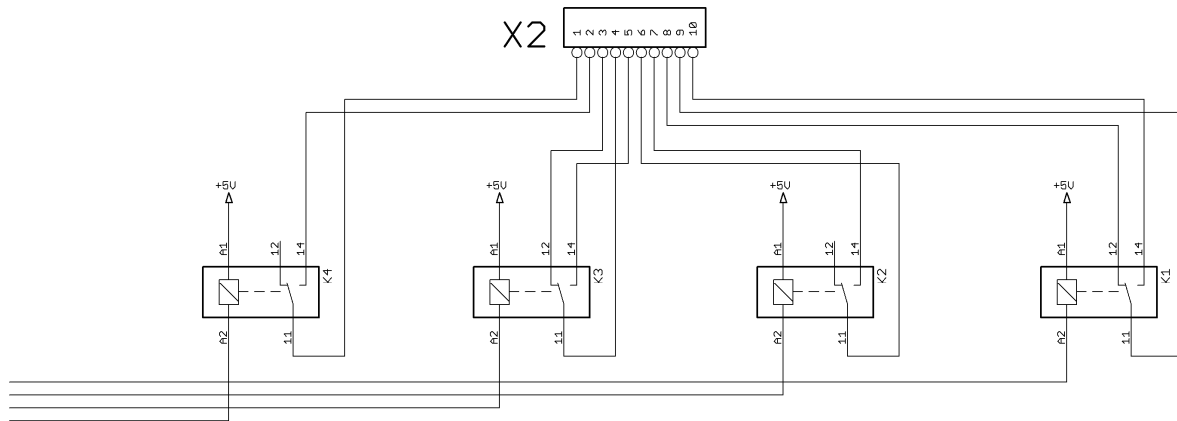

DIGITAL RELAY OUT 1 am Stecker X2

### Abmessungen Kunststoffgehäuse

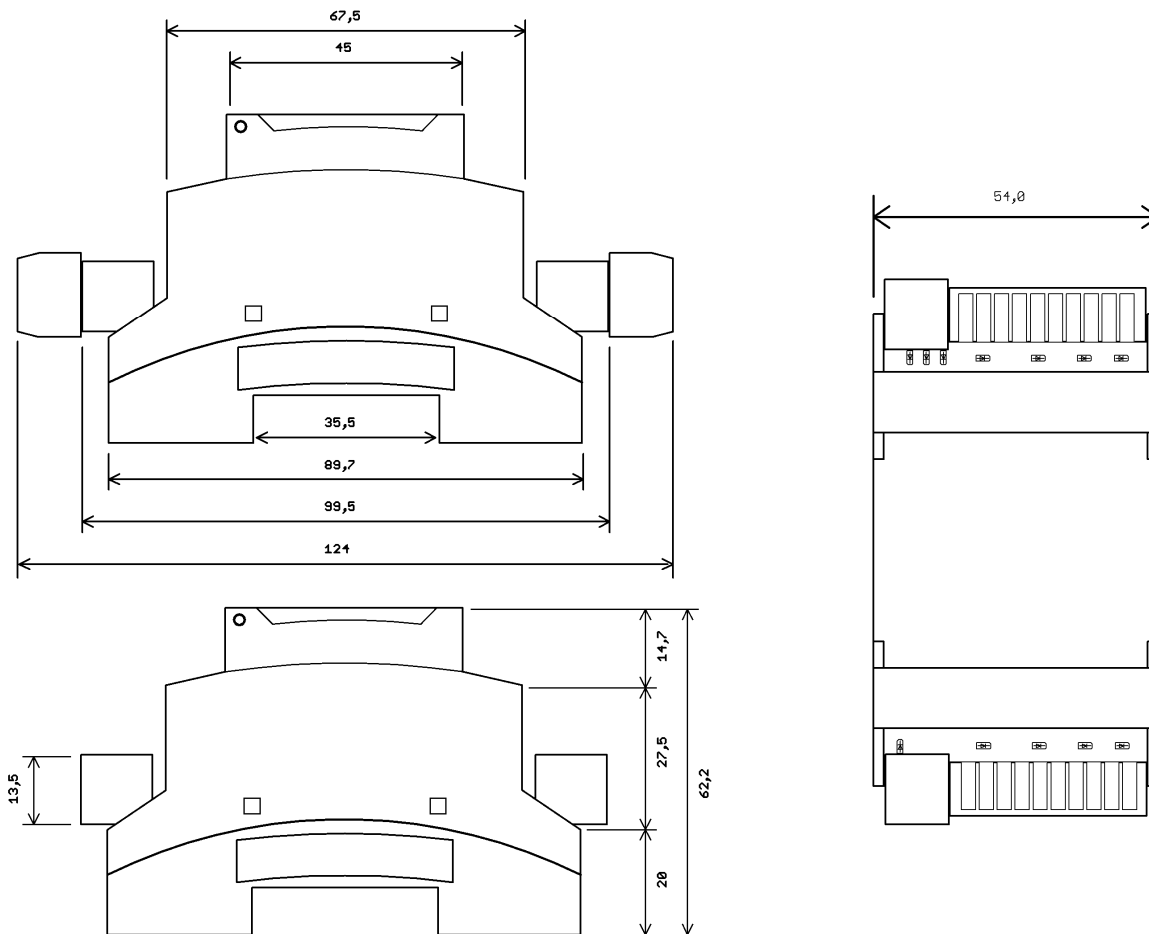

### CANopen Objektverzeichnis

Im hipecs-CIO101 Controller ist das komplexe Objektverzeichnis für CANopen E/A-Geräte implementiert.

#### hipecs-CIO101 Objekte

Alle Werte dieser Tabelle sind in hexadezimaler Schreibweise notiert. Als Zugriffsberechtigungen sind folgende Typen definiert:

ro read only / nur lesen

wo write only / nur schreiben

rw read and write access enabled / lesen und schreiben

rww read and write access enabled by SDO, write only by PDO / lesen, schreiben per SDO, PDO nur schreiben

Index	Sub-Index	Name	Data type	Acc.	Map-pable	Default Value / Note	Object Category
1000	-	Device Type	Unsigned 32	ro	no	0002 0191 h	Global
1001	-	Error Register	Unsigned 8	ro	yes	-	Global
1002	-	Manufacturer Status Register	Unsigned 32	ro	yes	-	Global
1005	-	COB-ID Sync Identifier Sync Object	Unsigned 32	ro	no	80 h	Global
1008	-	Device Name	Visible String	ro	no	"hipecs-CIO101"	Global
1009	-	Hardware Version	Visible String	ro	no	-	Global
100A	-	Software Version	Visible String	ro	no	active Version	Global
100C	-	Guard Time	Unsigned 16	rw	no	0 h	Global
100D	-	Life Time Factor	Unsigned 8	rw	no	0 h	Global
1014	-	COB ID Emergency	Unsigned 32	rw	no	80 h + Node-ID	Global
1015	-	Inhibit Time Emergency	Unsigned 16	rw	no	0 h ( disabled )	Global
1016	-	Consumer Heartbeat Time	Array	-	-	-	Global
	0	Nr of Subobjects	Unsigned 8	ro	no	04 h	Global
	1	Consumer Heartbeat Time 1	Unsigned 32	rw	no	0 h	Global
	2	Consumer Heartbeat Time 2	Unsigned 32	rw	no	0 h	Global
	3	Consumer Heartbeat Time 3	Unsigned 32	rw	no	0 h	Global
1017	-	Producer Heartbeat Time	Unsigned 16	rw	no	0 h	Global
	0	Nr of Subobjects	Unsigned 8	ro	no	04 h	Global
	1	Vendor ID	Unsigned 32	ro	no	0000 0058 h	Global
	2	Product Code	Unsigned 32	ro	no	0301 0100 h	Global
	3	Revision Number	Unsigned 32	ro	no	active Rev. Code	Global
1018	-	Identity Object	Record	-	-	-	Global
	0	Nr of Subobjects	Unsigned 8	ro	no	04 h	Global
	1	Vendor ID	Unsigned 32	ro	no	0000 0058 h	Global
	2	Product Code	Unsigned 32	ro	no	0301 0100 h	Global
1029	-	Error Behavior Object	Array	-	-	-	Global
	0	Nr of Subobjects	Unsigned 8	ro	no	2 h	Global
	1	Communication error	Unsigned 8	rw	no	0 h	Global
1400	-	Receive PDO0 - Communication Parameters	Record	-	-	-	PDO
	0	Nr of Subobjects	Unsigned 8	ro	no	2 h	PDO
	1	COB-ID	Unsigned 32	rw	no	200 h + Node-ID	PDO
1401	-	Receive PDO1 - Communication Parameters	Record	-	-	-	PDO
	0	Nr of Subobjects	Unsigned 8	ro	no	2 h	PDO
	1	COB-ID	Unsigned 32	rw	no	0x80000300 + Node-ID	PDO
	2	Transmission Type	Unsigned 8	rw	no	FF h	PDO

Index	Sub-Index	Name	Data type	Acc.	Map- pable	Default Value / Note	Object Category
1402		Receive PDO2 - Communication Parameters	Record	-	-	-	PDO
	0	Nr of Subobjects	Unsigned 8	ro	no	2 h	PDO
	1	COB-ID	Unsigned 32	rw	no	0x80000400 + Node-ID	PDO
	2	Transmission Type	Unsigned 8	rw	no	FF h	PDO
1403		Receive PDO3 - Communication Parameters	Record	-	-	-	PDO
	0	Nr of Subobjects	Unsigned 8	ro	no	2 h	PDO
	1	COB-ID	Unsigned 32	rw	no	0x80000500 + Node-ID	PDO
	2	Transmission Type	Unsigned 8	rw	no	FF h	PDO
1600		Receive PDO0 - Mapping Parameters	Record	-	-	-	PDO
	0	Nr of Subobjects	Unsigned 8	rw	no	2 h	PDO
	1	Mapped Object	Unsigned 32	rw	no	6200 01 08 h Dig. Output OUT00-OUT07	PDO
1601		Receive PDO1 - Mapping Parameters	Record	-	-	-	PDO
	0	Nr of Subobjects	Unsigned 8	rw	no	0 h	PDO
1602		Receive PDO2 - Mapping Parameters	Record	-	-	-	PDO
	0	Nr of Subobjects	Unsigned 8	rw	no	0 h	PDO
1603		Receive PDO3 - Mapping Parameters	Record	-	-	-	PDO
	0	Nr of Subobjects	Unsigned 8	rw	no	0 h	PDO
1800		Transmit PDO0 - Communication Parameters	Record	-	-	-	PDO
	0	Nr of Subobjects	Unsigned 8	ro	no	5 h	PDO
	1	COB-ID	Unsigned 32	rw	no	8000 01 80 h + Node-ID	PDO
	2	Transmission Type	Unsigned 8	rw	no	FF h	PDO
	3	Inhibit Time	Unsigned 16	rw	no	0 h	PDO
	4	Compatibility Entry	Unsigned 8	rw	no	-	PDO
	5	Event Time	Unsigned 16	rw	no	0 h	PDO
1801		Transmit PDO1 - Communication Parameters	Record	-	-	-	PDO
	0	Nr of Subobjects	Unsigned 8	ro	no	5 h	PDO
	1	COB-ID	Unsigned 32	rw	no	8000 02 80 h + Node-ID	PDO
	2	Transmission Type	Unsigned 8	rw	no	FF h	PDO
	3	Inhibit Time	Unsigned 16	rw	no	0 h	PDO
	4	Compatibility Entry	Unsigned 8	rw	no	-	PDO
	5	Event Time	Unsigned 16	rw	no	0 h	PDO
1802		Transmit PDO2 - Communication Parameters	Record	-	-	-	PDO
	0	Nr of Subobjects	Unsigned 8	ro	no	5 h	PDO
	1	COB-ID	Unsigned 32	rw	no	8000 03 80 h + Node-ID	PDO
	2	Transmission Type	Unsigned 8	rw	no	FF h	PDO
	3	Inhibit Time	Unsigned 16	rw	no	0 h	PDO
	4	Compatibility Entry	Unsigned 8	rw	no	-	PDO
	5	Event Time	Unsigned 16	rw	no	0 h	PDO

Index	Sub-Index	Name	Data type	Acc.	Map- pable	Default Value / Note	Object Category
1803		Transmit PDO2 - Communication Parameters	Record	-	-	-	PDO
	0	Nr of Subobjects	Unsigned 8	ro	no	5 h	PDO
	1	COB-ID	Unsigned 32	rw	no	8000 04 80 h + Node-ID	PDO
	2	Transmission Type	Unsigned 8	rw	no	FF h	PDO
	3	Inhibit Time	Unsigned 16	rw	no	0 h	PDO
	4	Compatibility Entry	Unsigned 8	rw	no	-	PDO
	5	Event Time	Unsigned 16	rw	no	0 h	PDO
1A00		Transmit PDO0 – Mapping Parameters	Record	-	-	-	PDO
	0	Nr of Subobjects	Unsigned 8	rw	no	0 h	PDO
1A01		Transmit PDO1 – Mapping Parameters	Record	-	-	-	PDO
	0	Nr of Subobjects	Unsigned 8	rw	no	0 h	PDO
1A02		Transmit PDO2 – Mapping Parameters	Record	-	-	-	PDO
	0	Nr of Subobjects	Unsigned 8	rw	no	0 h	PDO
1A03		Transmit PDO3 – Mapping Parameters	Record	-	-	-	PDO
	0	Nr of Subobjects	Unsigned 8	rw	no	0 h	PDO
2000	-	Device Manufacturer	Visible String	ro	no	"FRENZEL+BERG"	Global
2009		Serial Number 64 Bit	Array	-	-	-	Global
	0	Nr of Subobjects	Unsigned 8	ro	no	5 h	Global
	1	Serial Number 64 Bit LSDW	Unsigned 32	ro	no	-	Global
	2	Serial Number 64 Bit MSDW	Unsigned 32	ro	no	-	Global
2101	-	System Configuration	Unsigned 32	ro	no	Setting of Config. Input Pins	Global
2102	-	Remapping Enabled Info	Unsigned 8	ro	no	1 h ( enabled )	Global
2103	-	Enable Guarding Warning	Unsigned 8	rw	no	0 h ( disabled )	Global
2105	-	Internal API State	Unsigned 32	ro	yes	-	Global
2110		Conformance Test Object	Record	-	-	-	Global
	0	Nr of Subobjects	Unsigned 8	ro	no	1 h	Global
	1	Range Check Object	Unsigned 16	rw	no	500	Global
2180	-	CAN Restart Time	Unsigned 16	rw	no	1000 d ( restart after one second )	Global
5200	-	Reset Output Object on Error	Unsigned 8	rw	no	1 h	Dig. Output
6200		Write Digital Output 8 Bit	Array	-	-	-	Dig. Output
	0	Nr of Subobjects	Unsigned 8	ro	no	1 h	Dig. Output
	1	Dig. Output Byte 0	Unsigned 8	rw	yes	-	Dig. Output
6202		Change Polarity Output 8 bit	Array	-	-	-	Dig. Output
	0	Nr of Subobjects	Unsigned 8	ro	no	1 h	Dig. Output
	1	Polarity Output Byte 0	Unsigned 8	rw	no	0 h	Dig. Output
6206		Error Mode Output 8 bit	Array	-	-	-	Dig. Output
	0	Nr of Subobjects	Unsigned 8	ro	no	2 h	Dig. Output
	1	Error Mode Output 8 Bit Byte 0	Unsigned 8	rw	no	FF h	Dig. Output
6207		Error State Output	Array	-	-	-	Dig. Output
	0	Nr of Subobjects	Unsigned 8	ro	no	1 h	Dig. Output
	1	Error Value Output 8 Bit Byte 0	Unsigned 8	rw	no	0 h ( Inactive, high level )	Dig. Output
6300		Write Digital Output 16 bit	Array	-	-	-	Dig. Output
	0	Nr of Subobjects	Unsigned 8	ro	no	1 h	Dig. Output
	1	Dig. Output Word 1	Unsigned 16	rww	yes	-	Dig. Output



Index	Sub-Index	Name	Data type	Acc.	Map- pable	Default Value / Note	Object Category
6320		Write Digital Output 32 bit	Array	--	-	-	Dig. Output
	0	Nr of Subobjects	Unsigned 8	ro	no	1 h	Dig. Output
	1	Dig. Output Long 1	Unsigned 32	rww	yes	-	Dig. Output

### Bemerkung: DS301 PDO Parameter Objekte

Beschreibung der PDO-Parameter-Objekte

Diese Objekte ermöglichen ein dynamisches PDO-Mapping, variable PDO-Identifizier Einstellungen, das Einstellen der Übertragungsmodi, sowie inhibit und event time Konfiguration.

Die Einstellungen für diese CIO101 Parameter können alle im CANopen-Zustand „operational“, als auch im Zustand „pre-operational“ erfolgen.

### Description of Object Dictionary

The following list gives a short description of all dictionary entries, available for the hipecs-CIO series of CANopen I/O modules.

#### Index 0005

This object is implemented to enable reservation of data space in PDOs by mapping dummy entries.

Index	0005
Name	Dummy 8
Description	
Data Type	Unsigned 8
Access modes	RO
PDO Mapping	Yes
Value Range	-
Default Value	0

#### Index 0006

This object is implemented to enable reservation of data space in PDOs by mapping dummy entries.

Index	0006
Name	Dummy 16
Description	-
Data Type	Unsigned 16
Access modes	RO
PDO Mapping	Yes
Value Range	-
Default Value	0

#### Index 0007

This object is implemented to enable reservation of data space in PDOs by mapping dummy entries.

Index	0007
Name	Dummy 32
Description	-
Data Type	Unsigned 32
Access modes	RO
PDO Mapping	Yes
Value Range	-
Default Value	0

#### DS301: Global Objects

##### Index 1000 : Device Type

Description of the device type. The Object gives the CiA device profile number and additionally the functionality of the device.

Index	1000h
Name	Device Type
Description	-
Data Type	Unsigned 32
Access modes	RO
PDO Mapping	No
Value Range	-
Default Value	0002 0191 h

##### Index 1001 : Error Register

This object holds an error of the device.

Index	1001h
Name	Error Register
Description	-
Data Type	Unsigned 8
Access modes	RO
PDO Mapping	Yes
Value Range	-
Default Value	-

The error register has the following structure

Bit	Meaning
0	Generic error. This bit is set, if any error is active
1	0
2	0
3	0
4	CAN bus or communication error
5	0
6	0
7	Device Error

### Index 1002 : Status Register

This object gives additional information for the device

Index	1002h
Name	Status Register
Description	-
Data Type	Unsigned 32
Access modes	RO
PDO Mapping	Yes
Value Range	-
Default Value	-

### Index 1005 : COB-ID Sync

Identifier of Can Object for the Synchronisation message. The hipecs-CIO may only operate in Sync consumer mode. Generating of Sync messages is not possible. Therefore the Identifier for the Sync message can only be set to the value range 1 .. 7FFh.

Index	1005h
Name	COB-ID Sync
Description	-
Data Type	Unsigned 32
Access modes	RW
PDO Mapping	No
Value Range	1 .. 7FFh
Default Value	80h

### Index 1008 : Device Name

This object shows the name of the device as visible string.

Index	1008h
Name	Device Name
Description	-
Data Type	Visible String
Access modes	RO
PDO Mapping	No
Value Range	The maximum string length is 20 characters
Default Value	"hipecs-CIO101"

### Index 1009 : Hardware Version

This object shows the hardware version and firmware version as visible string.

Index	1009h
Name	Hardware Version
Description	-
Data Type	Visible String
Access modes	RO
PDO Mapping	No
Value Range	The maximum string length is 20 characters
Default Value	-

### Index 100A : Software Version

This object shows the software version as visible string.

Index	100Ah
Name	Software Version
Description	-
Data Type	Visible String
Access modes	RO
PDO Mapping	No
Value Range	The maximum string length is 20 characters
Default Value	-

### Index 100C : Guard Time

The objects at index 100Ch (Guard Time in milliseconds) and 100Dh (Life Time Factor) are used to implement the life guarding protocol. The Guard Time multiplied with the Life Time Factor gives the Life Time in milliseconds.

It is 0 (zero) if not used.

Index	100Ch
Name	Guard Time
Description	-
Data Type	Unsigned 16
Access modes	RW
PDO Mapping	No
Value Range	
Default Value	0

### Index 100D : Life Time Factor

The objects at index 100Ch (Guard Time in milliseconds) and 100Dh (Life Time Factor) are used to implement the life guarding protocol. The Guard Time multiplied with the Life Time Factor gives the Life Time in milliseconds. It is 0 (zero) if not used.

Index	100Dh
Name	Life Time Factor
Description	-
Data Type	Unsigned 8
Access modes	RW
PDO Mapping	No
Value Range	
Default Value	0

### Index 100E : COB-ID Guard

Identifier of Can Object for the Node Guarding protocol. The Object is not represented in the object dictionary because of standard conforming reasons.

Index	100Eh
Name	COB-ID Guard
Description	-
Data Type	Unsigned 32
Access modes	-
PDO Mapping	No
Value Range	-
Default Value	700h + Node-ID

### Index 1014 : COB-ID Emergency

Identifier of Can Object for the emergency messages.

Index	1014h
Name	COB-ID Emergency
Description	-
Data Type	Unsigned 32
Access modes	RW
PDO Mapping	No
Value Range	-
Default Value	80h + Node-ID

### Index 1015 : Inhibit Time Emergency

Inhibit Time for emergency messages. If the Inhibit Time is set to 0, inhibit delay is disabled. The Inhibit Time is a multiple of 100usec, but the hipecs-CIO offers a maximum resolution of 1 millisecond.

Index	1015h
Name	Inhibit Time Emergency
Description	-
Data Type	Unsigned 16
Access modes	RW
PDO Mapping	No
Value Range	-
Default Value	0 (disabled)

### Index 1016 : Consumer Heartbeat Time

The objects of Index 1016 are used to define the consumer heartbeat times for up to 4 nodes. With each sub index, the configuration for one monitored node can be set.

Index	1018h
Name	Consumer Heartbeat Time
Description	-
Data Type	Structure

Index	1016h Subindex 0
Name	Largest SubIndex supported
Description	-
Data Type	Unsigned 8
Access modes	RO
PDO Mapping	No
Value Range	-
Default Value	4

Index	1016h Subindex 1
Name	Consumer Heartbeat Time 1
Description	-
Data Type	Unsigned 32
Access modes	RW
PDO Mapping	No
Value Range	-
Default Value	0

Index	1016h Subindex 2
Name	Consumer Heartbeat Time 2
Description	-
Data Type	Unsigned 32
Access modes	RW
PDO Mapping	No
Value Range	-
Default Value	0

Index	1016h Subindex 3
Name	Consumer Heartbeat Time 3
Description	-
Data Type	Unsigned 32
Access modes	RW
PDO Mapping	No
Value Range	-
Default Value	0

Index	1016h Subindex 4
Name	Consumer Heartbeat Time 4
Description	-
Data Type	Unsigned 32
Access modes	RW
PDO Mapping	No
Value Range	-
Default Value	0

**Structure of consumer heartbeat time:**

MSB				LSB
	Byte3	Byte2	Byte1	Byte0
	reserved	Node-ID	Heartbeat time	

**Note:**

Monitoring of the heartbeat producer starts after the reception of the first heartbeat.  
 The consumer heartbeat time should be higher than the corresponding producer heartbeat time.  
 Before the reception of the first heartbeat the status of the heartbeat producer is unknown.

**Index 1017 : Producer Heartbeat Time**

The producer heartbeat time defines the cycle time of the heartbeat. The producer heartbeat time is 0 if it is not used. The time has to be a multiple of 1ms.

Index	1017h
Name	Producer Heartbeat Time
Description	-
Data Type	Unsigned 16
Access modes	RW
PDO Mapping	No
Value Range	-
Default Value	0

**Note:**

Either Heartbeat or node guarding may be allowed at the same time. Do not use both protocols at the same time.

**Index 1018 : Identity Object**

The object at index 1018h keeps general information of the device and the CANopen chip manufacturer frenzel + berg electronic GmbH & Co.KG. It cannot be modified.

Index	1018h
Name	Identity Object
Description	-
Data Type	Structure

Index	1018h Subindex 0
Name	Largest SubIndex supported
Description	-
Data Type	Unsigned char
Access modes	RO
PDO Mapping	No
Value Range	-
Default Value	4

Index	1018h Subindex 1
Name	Vendor ID
Description	Registration Code of frenzel + berg electronic at the CiA
Data Type	Unsigned 32
Access modes	RO
PDO Mapping	No
Value Range	-
Default Value	58h

Index	1018h Subindex 2
Name	Product Code
Description	Internal Product Code hipecs-CIO101 at frenzel + berg electronic
Data Type	Unsigned 32
Access modes	RO
PDO Mapping	No
Value Range	-
Default Value	0300 5000 h

Index	1018h Subindex 3
Name	Revision Code
Description	
Data Type	Unsigned 32
Access modes	RO
PDO Mapping	No
Value Range	-
Default Value	Revision of the device

Index	1018h Subindex 4
Name	Serial Number
Description	
Data Type	Unsigned 32
Access modes	RO
PDO Mapping	No
Value Range	-
Default Value	0

### Index 1029 : Error Behaviour

With object 1029 the CANopen chip can be configured to enter alternatively the preoperational or the stopped state or remain in the current state in case of a device failure. Device failures shall include the following communication errors:

Bus-off conditions of the CAN interface, Life guarding error, Serious device errors also can be caused by device internal failures.

The value of the Error Classes is as follows:

- 0 = pre-operational  
(only if current state is operational)
- 1 = no state change
- 2 = stopped
- 3 .. 127 = reserved

Index	1029h
Name	Error Behaviour Object
Description	-
Data Type	Structure

Index	1029h Subindex 0
Name	Largest SubIndex supported
Description	-
Data Type	Unsigned char
Access modes	RO
PDO Mapping	No
Value Range	-
Default Value	2

Index	1029h Subindex 1
Name	Communication Error
Description	NMT state change in case of communication error
Data Type	Unsigned 8
Access modes	RW
PDO Mapping	No
Value Range	-
Default Value	00h

Index	1029h Subindex 2
Name	Application Error
Description	NMT state change in case of internal error due to hardware malfunction
Data Type	Unsigned 8
Access modes	RW
PDO Mapping	No
Value Range	-
Default Value	00h

### DS301: PDO Parameter Objects

#### Communication Parameter Objects

The following table shows the communication parameter objects for Index 140x (Receive PDOs) and Index 180x (Transmit PDOs). The tables show Index 1400 as an example for all PDOs

The transmission type (sub-index 2) defines the mode for transmission / reception of the PDO. See table for detailed description of this entry.

Description of transmission type:

Type	PDO transmission				
	cyclic	acyclic	Sync related	Async.	Only on remote
0		X	X		
1-240	X		X		
241-251	Reserved				
252			X		X
253				X	X
254				X	
255				X	

Synchronous transmission types 0-240 and 252 mean that the transmission of the PDO shall be related to the SYNC object. Asynchronous means that the transmission of the PDO is not related to the SYNC object.

A transmission type of zero means that the message shall be transmitted synchronously with the SYNC object but not periodically but only in case of data change.

A value between 1 and 240 means that the PDO is transferred synchronously and cyclically, the transmission type indicating the number of SYNC signals, which are necessary to trigger PDO transmissions or receptions.

The transmission types 252 and 253 mean that the PDO is only transmitted on reception of a remote frame. At transmission type 252, the data is updated (but not sent) immediately after reception of the SYNC object. At transmission type 253 the data is updated at the reception of the remote frame. These values are only possible for transmit PDOs.

Transmission type 255 means, the application event is defined in the device profile. For receive PDOs the reception of a PDO will update the mapped data (normally the analog or digital outputs).

Sub-index 3h contains the inhibit time. This time is a minimum interval for PDO transmission. The value is defined as multiple of 100ms.

In mode 254/255 additionally an event time can be used for TPDO. If an event timer exists for a TPDO (value not equal to 0) the elapsed timer is considered to be an event. The event time is a multiple of 1 ms. This event will cause the transmission of this TPDO in addition to otherwise defined events.

The PDO communication parameter objects have the same structure for all PDOs. The following Objects are used.

Sub-index 4h is reserved.

Index	PDO
1400h	Receive PDO1
1401h	Receive PDO2
1402h	Receive PDO3
1403h	Receive PDO4
1800h	Transmit PDO1
1801h	Transmit PDO2
1802h	Transmit PDO3
1803h	Transmit PDO4

Index	14xxh / 18xxh
Name	Receive / Transmit PDOx Communication Parameters
Description	-
Data Type	Structure

Index	14xxh / 18xxh Subindex 0
Name	Largest SubIndex supported
Description	-
Data Type	Unsigned 8
Access modes	RO
PDO Mapping	No
Value Range	-
Default Value	2 / 5

Index	14xxh / 18xxh Subindex 1																
Name	COB-ID																
Description	Identifier for CAN-Object for PDO																
Data Type	Unsigned 32																
Access modes	RW																
PDO Mapping	No																
Value Range	-																
Default Value	<table border="1"> <tr> <td>1400.01</td> <td>Node-Id + 200h</td> </tr> <tr> <td>1401.01</td> <td>Node-Id + 80000300h</td> </tr> <tr> <td>1402.01</td> <td>Node-Id + 80000400h</td> </tr> <tr> <td>1403.01</td> <td>Node-Id + 80000500h</td> </tr> <tr> <td>1800.01</td> <td>Node-Id + 80000280h</td> </tr> <tr> <td>1801.01</td> <td>Node-Id + 80000280h</td> </tr> <tr> <td>1802.01</td> <td>Node-Id + 80000380h</td> </tr> <tr> <td>1803.01</td> <td>Node-Id + 80000480h</td> </tr> </table>	1400.01	Node-Id + 200h	1401.01	Node-Id + 80000300h	1402.01	Node-Id + 80000400h	1403.01	Node-Id + 80000500h	1800.01	Node-Id + 80000280h	1801.01	Node-Id + 80000280h	1802.01	Node-Id + 80000380h	1803.01	Node-Id + 80000480h
1400.01	Node-Id + 200h																
1401.01	Node-Id + 80000300h																
1402.01	Node-Id + 80000400h																
1403.01	Node-Id + 80000500h																
1800.01	Node-Id + 80000280h																
1801.01	Node-Id + 80000280h																
1802.01	Node-Id + 80000380h																
1803.01	Node-Id + 80000480h																

An Identifier of 8xxxxxxh means, that this PDO is disabled by default and must be enabled from the CANopen master by assigning a valid PDO ID.

Index	14xxh / 18xxh Subindex 2
Name	Transmission Type
Description	-
Data Type	Unsigned 8
Access modes	RW
PDO Mapping	No
Value Range	-
Default Value	0FFh / 01h

Index	14xxh / 18xxh Subindex 3
Name	Inhibit Time
Description	-
Data Type	Unsigned 16
Access modes	RW
PDO Mapping	No
Value Range	-
Default Value	0

Index	14xxh / 18xxh Subindex 4
Name	Reserved
Description	-
Data Type	-
Access modes	-
PDO Mapping	No
Value Range	-
Default Value	-

Index	14xxh / 18xxh Subindex 5
Name	Event Time
Description	-
Data Type	Unsigned 16
Access modes	RW
PDO Mapping	No
Value Range	-
Default Value	0

**Attention:** By default, only the transmit PDO 1 is enabled. Receive PDO2..4 and all transmit PDOs are disabled by default and must be activated by your CANopen Master if necessary.

### PDO Mapping Objects

The following table shows the PDO Mapping Objects. The principle of PDO mapping is the same for all PDOs. The PDO Mapping table is the cross reference between the Object dictionary entries (for example the data of a digital output byte) and the data field inside an PDO data field (position in the data field of a CAN message for PDO transfer).

Subindex 0 determines the valid number of objects that have been mapped. The hipecs-CIO allows a maximum of 8 mapped objects for each PDO. For changing the PDO mapping first subindex 0 must be set to 0 (mapping is deactivated). Then the objects can be remapped. When a new object is mapped by writing a subindex between 1 and 8, the device may check whether the object specified by index /subindex exists. If the object does not exist or the object cannot be mapped, the SDO transfer will be aborted.

Subindexes 1 to 8 keep the pointers of the mapped objects as unsigned 32 values. The value is 0 if there is no mapped object. The structure for these pointers is as follows.

MSB		LSB	
Byte3	Byte2	Byte1	Byte0
Mapped index		Subindex	Length

Mapped Index and Subindex together are the Pointer to the Object dictionary data to be mapped at this location.

Length gives the length of the mapped object in bits.

Index	160xh / 1A0xh
Name	Receive / Transmit PDO Mapping Parameters
Description	-
Data Type	Array

Index	160xh / 1A0xh Subindex 0
Name	Largest Subindex supported
Description	Number of mapped objects
Data Type	Unsigned 8
Access modes	RW
PDO Mapping	No
Value Range	-
Default Value	See table below



Index	160xh / 1A0xh Subindex 1 to 8
Name	Mapped object
Description	
Data Type	Unsigned 32
Access modes	RW
PDO Mapping	No
Value Range	-
Default Value	See table below

### Receive PDOs

The hipecs-CIO101 CANopen IO uses the following default mapping entries for receive PDO mapping:

Index	Entry	Explanation
Receive-PDO1		
1600.00	1	RPDO1: 1 mapped object
1600.01	62000108h	Digital Output Byte0
Receive-PDO2		
not activated		
Receive-PDO3		
not activated		
Receive-PDO4		
not activated		

**Attention:** Receive PDO1 is active by default. RPDO2..4 have to be activated by CANopen Master.

### Transmit PDOs

The hipecs-CIO101 CANopen IO uses the following default mapping entries for transmit PDO mapping:

Index	Entry	Explanation
Transmit - PDO1		
not activated		
Transmit – PDO2		
not activated		
Transmit – PDO3		
not activated		
Transmit – PDO4		
not activated		

**Attention:** All transmit PDOs are disabled by default for this module.

## Manufacturer Specific Profile Area

The Objects in this area offer special device specific functions in order to configure additional functions implemented in the devices firmware. These additional functions can not be edited within the standardized profile areas.

### Index 2000 : Device Manufacturer

This Object shows "Frenzel + Berg" as visible string. If OEMs do not want to give access to this entry, it may be removed from the EDS (electronic data sheet).

Index	2000h
Name	Device Manufacturer
Description	-
Data Type	Visible String
Access modes	RO
PDO Mapping	No
Value Range	The maximum string length is 20 characters
Default Value	„FRENZEL + BERG“

### Index 2101 : System Configuration

This Object returns the operation mode of the hipecs-CIO101.

Index	2101h
Name	System Configuration
Description	-
Data Type	Unsigned 32
Access modes	RO
PDO Mapping	No
Value Range	-
Default Value	0

### Index 2102 : Remapping Enabled Info

This Object informs the user whether the system configuration enables remapping of the PDOs. A value of 0 means that remapping is disabled, all other values indicate that remapping of the PDOs is enabled.

Index	2102h
Name	Remapping Enabled Info
Description	-
Data Type	Unsigned 8
Access modes	RO
PDO Mapping	No
Value Range	-
Default Value	1

### Index 2103 : Enabled Guarding Warning

This Object enables/disables transmission of emergency messages in case of a node guarding warning.

The condition of a guarding warning is met, if the time between two node guarding frames increases the guarding time given in object 100C independent of the setting of the life time (object 100D). The node guarding warning does not cause any NMT state change or switching the output pins to the error state. It is implemented to give the CANopen master an early information that the guarding interval has already exceeded the predefined value.

0 : Guarding Warning is disabled  
1 : Guarding Warning is enabled

Index	2103h
Name	Enable Guarding Warning
Description	-
Data Type	Unsigned 8
Access modes	RW
PDO Mapping	No
Value Range	-
Default Value	0

### Index 2105 : Internal Error Code

This Object holds error information of the CANopen controller.

Index	2105h
Name	Internal Error Code
Description	-
Data Type	Unsigned 32
Access modes	RO
PDO Mapping	YES
Value Range	-
Default Value	0 (no error condition)

### Index 2110 : Test Object

This Object is implemented for testing purposes and should not be used.

The test entry does not have any functional behaviour.

Index	2110h
Name	Test Object 01
Description	-
Data Type	Structure

Index	2110h Subindex 0
Name	Largest SubIndex supported
Description	-
Data Type	Unsigned char
Access modes	RO
PDO Mapping	No
Value Range	-
Default Value	0x01

Index	2110h Subindex 1
Name	Range Check Object
Description	-
Data Type	Unsigned 16
Access modes	RW
PDO Mapping	No
Value Range	100 .. 1000
Default Value	500

### Index 2180 : CAN Restart Time

This Object gives the restart time out for the CAN communication layer in case of bus off errors in milliseconds.

If the restart time is set to 0 automatic restart of the device in case of bus off is prohibited.

Index	2180h
Name	CAN Restart Time
Description	-
Data Type	Unsigned 16
Access modes	RW
PDO Mapping	No
Value Range	0 .. 50000
Default Value	1000 (restart after one second)

### Special Function Related Objects

These Objects are related to the CIO101s special functions.

#### Index 5200 : Output Reset on Error Option

This Object selects the function for error handling if a critical error is detected.

If the value is 0, the Outputs objects 6200.xx will keep unchanged. The ports will be set to their error state given in object 6207 as long as the error is active. If error condition ends, the outputs will return to the state according to the output object 6200h.

If the value is 1, the Outputs error handling depends on the objects 6206h and 6207h and the output object 6200 will be overwritten with the error output state according to objects 6206 and 6207.

Index	5200h
Name	Output Reset on Error Option
Description	-
Data Type	Unsigned 8
Access modes	RW
PDO Mapping	No
Value Range	-
Default Value	1

### DS401: I/O Configuration Objects

The following objects are describing the objects for configuration of the input and output channels.

#### DS401: Digital Output Objects

The following objects are describing the functionality of the digital output lines of the hipecs-CIO. The hipecs CIO101 supports 8, 16 and 32 bit access to the digital outputs.

The mapping of the I/O lines to object 6200 is explained in chapter "Mapping I/O to Object Dictionary"

#### Index 6200 : Write to Digital Output

With object 6200, the digital outputs of the hipecs-CIO can be written.

Index	6200h
Name	Write to digital output
Description	-
Data Type	Array

Index	Subindex 0
Name	
Description	Number of mapped objects
Data Type	Unsigned 8
Access modes	RO
PDO Mapping	NO
Value Range	-
Default Value	1h

Index	Subindex 1
Name	Write to digital output 0
Description	Object For Digital Output Byte 0
Data Type	Unsigned 8
Access modes	RW
PDO Mapping	YES
Value Range	-
Default Value	0

### Index 6202 : Polarity Output 8 Bit

With this object, the digital outputs may be inverted. See also Index 6200 for additional information.

Index	6202h
Name	Polarity Output 8 Bit
Description	-
Data Type	Array

Index	Subindex 0
Name	Nr of Subobjects
Description	
Data Type	Unsigned 8
Access modes	RO
PDO Mapping	No
Value Range	-
Default Value	1h

Index	Subindex 1
Name	Polarity Output 8 Bit Byte 0
Description	
Data Type	Unsigned 8
Access modes	RW
PDO Mapping	No
Value Range	-
Default Value	0

### Index 6206 : Error Mode Output 8 Bit

This object indicates bitwise, whether an output is forced to a predefined value (given in object 6207) in case of a device error.

- 1 = Output will be forced to the value selected in object 6207
- 0 = Output will be unchanged even in case of an error condition.

Index	6206h
Name	Error Mode Output 8 Bit
Description	-
Data Type	Array

Index	Subindex 0
Name	Nr of Subobjects
Description	
Data Type	Unsigned 8
Access modes	RO
PDO Mapping	No
Value Range	-
Default Value	1h

Index	Subindex 1
Name	Error Mode Output 8 Bit Byte 0
Description	
Data Type	Unsigned 8
Access modes	RW
PDO Mapping	No
Value Range	-
Default Value	0FFh (Take error condition from object 6207)

### Index 6207 : Error Value Output 8 Bit

This object selects the level the outputs are forced to in case of device error mode if the error mode (object 6206 is enabled)

- 1 = Output will be forced to active state
- 0 = Output will be forced to inactive state.

Index	6207h
Name	Error Value Output 8 Bit
Description	-
Data Type	Array

Index	Subindex 0
Name	Nr of Subobjects
Description	
Data Type	Unsigned 8
Access modes	RO
PDO Mapping	No
Value Range	-
Default Value	1h

Index	Subindex 1
Name	Error Value Output 8 Bit Byte n
Description	
Data Type	Unsigned 8
Access modes	RW
PDO Mapping	No
Value Range	-
Default Value	0 (Inactive, high level)

### Index 6300 : Write Digital Output 16 Bit

This object enables 16-Bit access to the digital output bytes. The Object addresses the same data area as object 6200 but using unsigned integer data type. See Index 6200 for further details.

### Index 6320 : Write Digital Output 32 Bit

This object enables 32-Bit access to the digital output bytes. The Object addresses the same data area as object 6200 but using unsigned long data type. See Index 6200 for further details.

### Emergency Messages

Das hipecs-CIO101 Modul unterstützt diverse Emergency Messages. Für alle Emergency Messages wird die selbe Struktur angewendet.

Byte								
0	1	2	3	4	5	6	7	
EMY-Code	1001	0	CIOXXX-Code					

EMY-Code: Emergency-Error-Code nach DS301

1001: Inhalt von Object 1001

CIO101-Code: Emergency-Error-Code CIO101 als unsigned 32 Wert

CIO-XXX-Code (hex)	ändert:		Beschreibung
	NMT	I/O	
8000 0000	X	X	CAN bus ist bus off
4000 0000			CAN bus in error warning state
2000 0000			Node guarding Warnung
3000 0000	X	X	Life guarding error
0000 0001	X	X	Überlast am Ausgang
0000 0100			Wake up vom Power down Modus

Die Emergency 2000 0000 (Node guarding Warnung) muss über das Objekt 2103 freigeschalten werden.

Wenn mehr als eine Fehlermeldung zur selben Zeit aktiv sind, wird das CIO101-Code Bitmuster durch eine logische Verknüpfung der einzelnen Codes gebildet.

Manche der Emergency Messages können einen NMT-State-Wechsel bewirken oder die Ausgänge in den Fehlerzustand setzen. Des jeweiligen Verhalten hängt von den Einstellungen im Objekt 1029 ab.

Der Identifier für die Emergency-Nachrichten ist festgelegt auf: **0x80 + Knotennummer**

Liste der Emergency-Nachrichten:

Node-Guarding Warnung							
30	81	01	00	00	00	00	20

Diese Nachricht wird vom Knoten gesendet, wenn der Master nicht innerhalb der spezifizierten „guard time“ (Objekt 100C) einen „guarding remote frame“ sendet. Diese Funktion wird im Objekt 2103 eingestellt.

Life-Guarding Fehler							
30	81	11	00	00	00	00	30

Dieser Fehler tritt auf, wenn der Master nicht innerhalb der eingestellten „Life Time“ einen

„guarding remote frame“. (Guard Time im Objekt 100C multipliziert mit dem Lifetime-Faktor Objekt 100D)

Ausgangsüberlast Fehler							
10	23	01	00	01	00	00	00

Fehlermeldung wenn die maximale Ausgangslast für die digitalen Ausgänge überschritten wird.

CAN Bus im Error Warning state							
00	81	01	00	00	00	00	40

Fehlermeldung wenn sich das chipinterne CAN-Modul im „error warning state“ befindet.

Rückkehr aus CAN-Bus-Off							
40	81	01	00	00	00	00	C0

Mit dieser Nachricht zeigt der Knoten seine Rückkehr vom Bus-Off-Zustand an.

### Daten-Mapping im Objektverzeichnis

Betriebsmodus 0 / CFG 0 / DIP 8 = OFF							
8 digitale Ausgänge / Relais							
EDS-file: hipecs_CIO101.EDS							
Mapping im Objektverzeichnis							
Index	SubIndex	gemapptes I/O Signal Bit/Wert					
		7	6	5	4	3	2
6200.01		OUT0.7 bis OUT0.0					
Default PDO Mapping							
PDO		gemappte Daten					
RPDO0		6200.01 dig. Ausgänge OUT0 bis 7 / Relais 0 .. 7					

**Version History**

Version	Datum	Änderung
1.00 Rev. 01	16.09.2013	Erste Version
1.51 Rev. 01	18.09.2013	Version des Datenblattes der Softwareversion angepasst Temperaturbereich von 0 .. 70°C auf 0 .. 55°C geändert
1.51 Rev. 03	21.10.2014	Aktualisierung Temperaturbereiche
1.51 Rev. 04	19.02.2015	Bestellinformationen ergänzt
1.51 Rev. 05	25.11.2015	CAN-Baudrate 10kBit entfernt (nicht unterstützt)

### Inhaltsverzeichnis

Allgemein .....	1	Special Function Related Objects .....	19
Funktionen .....	1	Index 5200 : Output Reset on Error Option .....	19
Bestellinformation .....	1	<b>DS401: I/O Configuration Objects .....</b>	<b>19</b>
Technische Daten .....	2	<b>DS401: Digital Output Objects.....</b>	<b>19</b>
Steckerbelegung X1 ( CAN ) .....	3	Index 6200 : Write to Digital Output.....	19
Steckerbelegung X2 (Relay Out 1) .....	3	Index 6202 : Polarity Output 8 Bit .....	20
Steckerbelegung X3 (Versorgung).....	3	Index 6206 : Error Mode Output 8 Bit .....	20
Steckerbelegung X4 (Relay Out 0) .....	3	Index 6207 : Error Value Output 8 Bit .....	20
Konfiguration Dip-Schalter DIP1 und DIP2.....	4	Index 6300 : Write Digital Output 16 Bit.....	20
CAN Signal LED's .....	4	Index 6320 : Write Digital Output 32 Bit.....	20
Prinzipschaltbild Relaisbeschaltung .....	5	<b>Emergency Messages .....</b>	<b>21</b>
Abmessungen Kunststoffgehäuse.....	5	<b>Daten-Mapping im Objektverzeichnis.....</b>	<b>21</b>
<b>CANopen Objektverzeichnis.....</b>	<b>6</b>	<b>Version History .....</b>	<b>22</b>
Bemerkung: DS301 PDO Parameter Objekte.....	9	<b>Inhaltsverzeichnis .....</b>	<b>23</b>
<b>Description of Object Dictionary .....</b>	<b>10</b>		
Index 0005.....	10		
Index 0006.....	10		
Index 0007.....	10		
<b>DS301: Global Objects .....</b>	<b>10</b>		
Index 1000 : Device Type .....	10		
Index 1001 : Error Register.....	10		
Index 1002 : Status Register .....	11		
Index 1005 : COB-ID Sync .....	11		
Index 1008 : Device Name .....	11		
Index 1009 : Hardware Version .....	11		
Index 100A : Software Version .....	11		
Index 100C : Guard Time .....	11		
Index 100D : Life Time Factor .....	12		
Index 100E : COB-ID Guard.....	12		
Index 1014 : COB-ID Emergency .....	12		
Index 1015 : Inhibit Time Emergency .....	12		
Index 1016 : Consumer Heartbeat Time.....	12		
Index 1017 : Producer Heartbeat Time.....	13		
Index 1018 : Identity Object.....	13		
Index 1029 : Error Behaviour.....	14		
<b>DS301: PDO Parameter Objects .....</b>	<b>15</b>		
Communication Parameter Objects .....	15		
PDO Mapping Objects .....	16		
<b>Manufacturer Specific Profile Area .....</b>	<b>17</b>		
Index 2000 : Device Manufacturer .....	17		
Index 2101 : System Configuration.....	17		
Index 2102 : Remapping Enabled Info.....	18		
Index 2103 : Enabled Guarding Warning.....	18		
Index 2105 : Internal Error Code.....	18		
Index 2110 : Test Object.....	18		
Index 2180 : CAN Restart Time .....	18		