

General Description

The CO401GW1 is a low cost, high performance Single Chip solution for CANopen gateway applications. The chip enables serial connections to a standard CANopen network.

The device offers the complex implementation of the CANopen standards DS301 and DS401. On the CANopen bus side, the device simulates a CANopen slave node with either 8 digital input bytes, 4 analog input channels, 8 digital output bytes and 4 analog output channels or 16 digital input and 16 digital output byte. In any case there is a total of 16 Bytes, that can be transferred in each direction. The device offers 8 digital input bits and 8 digital output bits. The rest of the I/O area is realized as transfer memory for the gateway functionality. The access to this virtual I/O area is done via serial interface using a simple protocol.

The CO401GW1 implements the complete object dictionary and handles the CANopen bus line autonomously.

The CANopen Chip requires only few external components, just like a crystal, a CAN transceiver and capacitors. To minimize external interface recommendations all output pins have high current drive capability of 4 mA. For interfacing optoisolators no external drivers are required.



CANopen Features

- 2 Transmit- and 2 Receive PDOs
- Variable PDO identifier
- All CANopen specific PDO transmission types supported: synchronous, asynchronous, event driven, cyclic, acyclic and remote frame dependent.
- Event timer and inhibit timer features for all transmit PDOs.
- Storing and restoring of object dictionary to non-volatile memory
- Node guarding, Life guarding, Heartbeat
- Emergency messages
- Minimum boot up

Features

- Single Chip CANopen Controller
- According to CiA Draft Standards DS301 Version 4.0 and DS401 Version 2
- Gateway Interface using UART with programmable Baudrate
- CAN-Baudrate up to 1MBit
- Output drivers with 4mA
- Watchdog output
- Temperature ranges up to -40 to 105 °C
- Package QFP64

Ordering Information

CO401-GW1
(programmed, licence included)

Part	Temp. Range	Package
CO401GW1A-FL	-40 °C to 85 °C	QFP64
CO401GW1AE-FL	-40 °C to 105 °C	QFP64

Applications

- Connection of micro controller applications to CANopen networks
- CANopen slave controller for existing applications

Pin Assignment

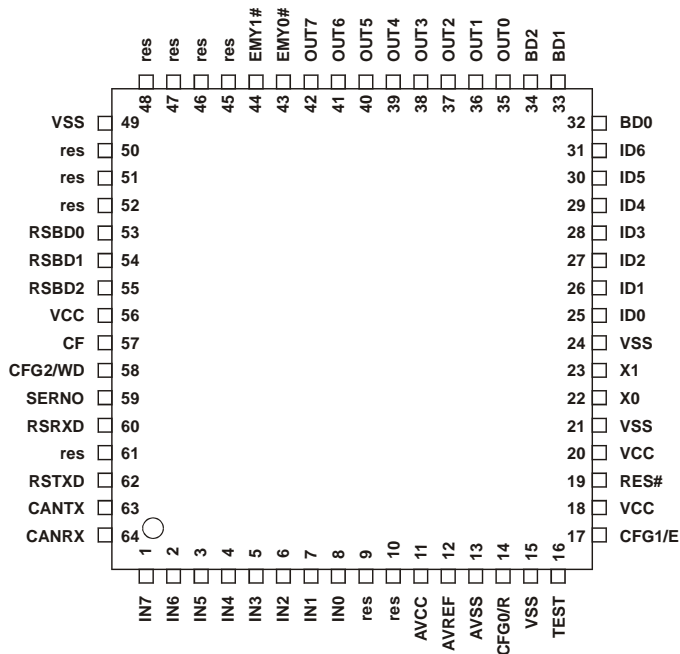

Pin Listing continued

Pin No.	Pin Name	Funktion
43	EMY0#	Emergency Input 0 Active low
44	EMY1#	Emergency Input 1 Active low
53 .. 55	RSBD0 .. RSBD2	Serial interface baud rate selection
57	CF	Filter capacitor input
58	CFG2/WD	Configuration input Bit2 Watchdog output
59	SERNO	Interface pin for connecting a silicon serial number
60*	RSRXD	Serial interface receiver input line
62*	RSTXD	Serial interface transmitter output line
63	CANTX	Transmitter output of CAN module
64	CANRX	Receiver input of CAN module
15, 21*, 24, 49	VSS	Ground
18*, 20, 56	VCC	Power supply
	res	Reserved for future use

Pin Listing

Pin No.	Pin Name	Funktion
1 .. 8	IN7 .. IN0	Digital Input channels
11	AVCC	Power supply A/D converter
12	AVREF	Reference A/D converter
13	AVSS	Ground A/D converter
14	CFG0/R	Configuration input Bit0 CANopen run LED output
16	TEST	Do not connect this pin
17	CFG1/E	Configuration input Bit1 CANopen error LED output
19	RES#	Reset input active low
22	X0	Crystal oscillator input
23	X1	Crystal oscillator output
25 .. 31	ID0 .. ID6	CANopen Identifier selection input bits
32 .. 34	BD0 to BD2	CANopen baud rate selection input bits
35 .. 42	OUT0 .. OUT7	Digital output channels

*) Pins are used for in circuit programming of Fujitsu MB90F497. See "in circuit programming manual" for further information.

Pin Description

All input / output pins are high impedance during reset. The CO401GW1 supports no internal pull up resistors so external devices are required.

Note:

In order to keep compatibility with future versions of the CO401GW1 chip, add a weak external pull up of approx 10kOhms to all reserved pins.

All input pins have Schmitt trigger characteristics.

IN0 to IN7: Digital Input Pins

Digital input pins. If the digital input pins are enabled, Object 6000.01 is not added to the gateway memory but read from this input port.

Note: Digital input pins are active low. This means that digital input pins are mapped with inverted values to object and transmit PDO data.

OUT0 to OUT7: Digital Output Pins

All output pins have high current drive capabilities of approximate 4 mA for direct interfacing for opto couplers without additional drivers. The output pins are driven with the data held in object 6200.01. This data is written to the gateway data and to the output port pins.

Note: Digital output pins are active low. This means that received output data from PDO is written with inverted values to output pins.

EMY0# / EMY1#: Emergency Input

A low level at the emergency input pins causes the CO401GW1 controller to send an Emergency Message to the CANopen network. A low level at pin EMY0# causes a critical error that will force the digital output pins to their error state. EMY0# may also change NMT state according to the settings in object 1029.2. A low level at pin EMY1# causes an uncritical error that only will generate an Emergency message, but there is no reaction at the output pins and there is no reaction of the NMT state.

Emergency-Message-Data if EMY0# at low-Level:

Data Byte of Emergency Message							
0	1	2	3	4	5	6	7
10	23	01	00	01	00	00	00

Emergency-Message-Data if EMY1# at low-Level:

Data Byte of Emergency Message							
0	1	2	3	4	5	6	7
00	10	01	00	10	00	00	00

CFG0/R: Configuration input / Run-LED

CFG0/R is scanned during reset as configuration input pin. Then CFG0/R is switched to an active low output and drives the CANopen Run LED according to the DRP303-3 standard, with exception in NMT state "operational" the Run-LED flickers with a duty cycle of 95%. This shows the user that the system is still running. For the circuit driving the LED it must be taken care, that the CANopen controller must read the correct CMOS level for configuration setting during reset.

CFG1/E: Configuration input / Error-LED

CFG1/E is scanned during reset as configuration input pin. Then CFG1/E is switched to an active low output and drives the CANopen Error LED according to the DRP303-3 standard. For the circuit driving the LED it must be taken care, that the CANopen controller must read the correct CMOS level for configuration setting during reset.

CFG2/WD: Configuration input / watchdog output

CFG2/WD is scanned during reset as configuration input pin. Then CFG2/WD is switched to an active low output and drives the watchdog trigger. To monitor correct device operation, this feature may be used in combination with an external watchdog timer. For the circuit driving the watch dog it must be taken care, that the CANopen controller must read the correct CMOS level for configuration setting during reset.

CANRX, CANTX: CAN interface pins

The CAN interface pins may be used for direct connection to CAN transceivers like the 80C251. For longer bus length or noisy or disturbed environments it is strongly recommended to use galvanic isolation with opto couplers between bus interface and CANopen application, to improve system reliability.

RSRXD, RSTXD: RS232 interface pins

The serial interface pins for the gateway may be used for direct connection to RS232 transceivers like the MAX232. For longer bus length or noisy or disturbed environments it is strongly recommended to use galvanic isolation with opto couplers between the CO401GW1 and the RS232 line.

RES#: Reset input pin

For a correct device reset, provide an active low reset signal according to recommended operation conditions to input RESET#.

X0, X1: Crystal oscillator input

Connect a crystal of 4 MHz between X0 and X1. Use additional ceramic capacitors of 22 pF from X0 to VSS and X1 to VSS.

BD0 to BD2: CAN baud rate configuration bits

Set the baud rate for the CAN interface using this bits.

RSBD0 to RSBD2: Serial baud rate configuration bits

Set the baud rate for the serial interface using this bits.

ID0 to ID7: CANopen identifier selection bits

Set the device identifier for the CANopen interface using this bits.

SERNO: Silicon Serial Number Input

Pin used to connect to a silicon serial number chip for example the Dallas DS2401. This feature will be used in future versions of the CO401GW1 in order to support the LSS services. It is recommended to place a pull up resistor of 10kOhms to this pin, if no silicon serial number chip is used.

VCC, AVCC, VSS, AVSS: Power Supply Pins

Make sure that all ground and power supply pins are connected to the same potential. Do not leave any ground or power supply pins open. Connect decoupling capacitors as close as possible to the device. See chapter "Recommended Operation Conditions" for details

CF: Filter Capacitor input

For correct operation of the CANopen gateway chip a ceramic capacitor of 100 nF or 220 nF must be connected between Pin CF and VSS. Place this component as close as possible to the device.

AVREF: Reference Voltage for A/D Converter

Reference Voltage for the A/D converter. Future versions of the CO401GW1 chip might support two analog input channels.

Test: Reserved Pin

Leave this pin unconnected

Handling the Device

Preventing latch up

The CANopen Gateway Chip is a CMOS device and may suffer latch up under the following conditions:

- 1) A voltage higher than VCC or lower than VSS is applied to any pin.
- 2) Absolute maximum ratings are exceeded

Handling unused Pins

Do not leave unused input pins open. This might cause malfunction of the device.

Input / output pins

All input and output pins for digital signals are active low. This means for input pins, that inverted pin level is mapped to PDO. For output pins the inverted byte value from received PDO is written to the output pins.

Additional inverting capabilities are supported

Power Supply Pins

Make sure that all ground and power supply pins are connected to the same potential. Do not leave any ground or power pins open. Connect at least two ceramic capacitors of 100 nF and a tantalium capacitor of 1 uF between VCC and VSS as close as possible to the device.

Power Supply for A/D converter

The power supply for the A/D converter must not be turned on before the power supply VCC.

If the A/D converter is not used, connect the pins as follows: AVCC = AVREF = VCC, AVSS = VSS.

Pull up/down resistors

The CANopen Gateway Chip supports no internal pull up resistors use external components where needed.

In Circuit programming

If you want to enable in circuit programming of the Fujitsu MB90F497 micro controller for CANopen Gateway Chip software download or update, the following conditions must be met.

Pin No.	Pin Name	Pin Setting for in circuit programming
21	VSS/MD2	Level = High
18	VCC/MD0	Level = Low
60	RSRXD	RXD Programming interface receiver pin (CMOS – logic level)
62	RSTXD	RXD Programming interface transmitter pin (CMOS – logic level)

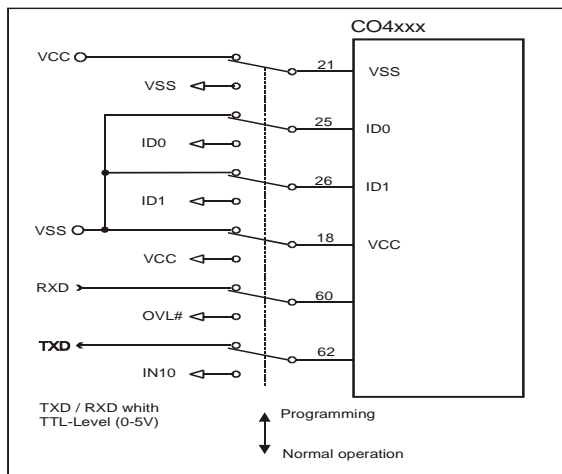

Design example for programming adaptor.

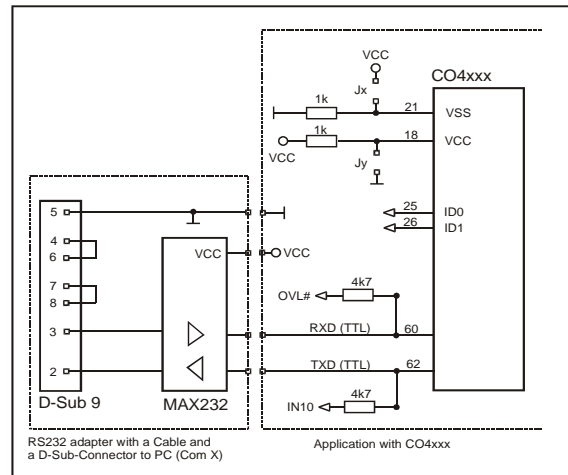

To enable the programming condition close the jumpers Jx and Jy.

For optimised programming adapter design, the programming adapter should close the jumpers Jx and Jy directly by plugging the adaptor into the application board.

For normal operation mode the programming adapter must be removed.

The node ID must be set to a value that forces pins ID0 and ID1 to low level. For example set node ID to 3.

Device Configuration

The following sections describe the device configuration with meaning:

1: ViH logic high level
0: ViL logic low level

CAN Identifier

The CAN Identifier will be set with Pins ID0 to ID6. ID7 is reserved for future use. This configuration pins use internal inverter. The ID is set as follows:

ID6	ID5	ID4	ID3	ID2	ID1	ID0	CAN-Identifier
1	1	1	1	1	1	1	Programmable ID
1	1	1	1	1	1	0	1 = 0x01
1	1	1	1	1	0	1	2 = 0x02
1	1	1	1	1	0	0	3 = 0x03
1	1	1	1	0	1	1	4 = 0x04
		
1	0	0	0	0	0	0	63 = 0x3F
0	1	1	1	1	1	1	64 = 0x40
0	1	1	1	1	1	0	65 = 0x41
		
0	0	0	0	0	1	0	125 = 0x7C
0	0	0	0	0	0	1	126 = 0x7E
0	0	0	0	0	0	0	127 = 0x7F

All Identifiers from 1 to 127 are valid settings.

CAN baud rate

The baud rate configuration will be done with configuration inputs BD0 to BD2

BD2	BD1	BD0	CAN-Baud Rate / Bus length
1	1	1	1 Mbit/sec 25 m *1)
1	1	0	800 kbit/sec 50 m *1)
1	0	1	500 kbit/sec 100 m *2)
1	0	0	250 kbit/sec 250 m *2)
0	1	1	125 kbit/sec 500 m *3)
0	1	0	50 kbit/sec 1000 m *3)
0	0	1	20 kbit/sec 2500 m *3)
0	0	0	10 kbit/sec 5000 m *3)

- *1) Calculation without optocouplers.
For optocouplers bus length is reduced for about 4m per 10 nsec propagation delay of employed optocoupler type
- *2) Calculation with 40 nsec optocoupler propagation delay
- *3) Calculation with 100 nsec optocoupler propagation delay

The calculation of the bus length is based on a line propagation delay of 5 nsec/m.

Serial baud rate

The serial baud rate configuration for the serial gateway interface will be done with configuration inputs RSBD0 to RSBD2

RS BD2	RS BD1	RS BD0	Serial Interface Baud Rate	
			nominal	Exact
1	1	1	9600	9615
1	1	0	4800	4807
1	0	1	2400	2404
1	0	0	Reserved	-
0	1	1	76900	76923
0	1	0	38400	38461
0	0	1	19200	19230
0	0	0	Reserved	-

Device Configuration Pins

With the device configuration input bits the CANopen Gateway Chip can be adapted to several application requirements.

CFG0 is used to enable/disable the digital input lines by default. CFG1 is used to select the operation mode.

CFG2 is reserved for future use.

CFG			Setting
2	1	0	
X	X	1	Digital hardware inputs enabled
X	X	0	Digital hardware inputs disabled
X	1	X	Analog/Digital Mixed mode The devices simulates: 8 digital input bytes 8 digital output bytes 4 analog input integers 4 analog output integers
X	0	X	digital only mode The devices simulates: 16 digital input bytes 16 digital output bytes

In order to keep compatibility to future versions of the CO401GW1 controller it is strongly recommended to place a pull up resistors of approx 10k to the reserved configuration input pins.

Asynchronous Serial Interface

The CANopen Gateway Chip behaves as a digital/analog I/O system on the CANopen bus. It offers 2 PDOs for each direction (transmit and receive). Each PDO keeps 8 data bytes. So the CO401GW1 chip offers a total of 16 data bytes of memory that can be transferred over the gateway in each direction using the fast PDO transfer.

The CANopen Gateway supports an asynchronous serial interface to access the CANopen object dictionary or the data bytes transferred within the PDOs. The data that will be transmitted over the serial gateway interface will not only be exchanged with the PDO data memory, but also with the PDO related objects. This will give consistent data also for SDO transfer on the CANopen network.

There is a simple protocol for transferring the data with an asynchronous serial interface between the CANopen Gateway Chip and an other Host. The protocol bytes sent from the host must be sent in a continuous data stream. If the CO401GW1 chip detects a pause of more than 10 milliseconds between two bytes, the current protocol is marked as invalid and terminated. In order to synchronize the serial protocol, the host has to insert a pause of 50 msec without sending any data on the serial line. This pause will cause the CO401GW1 chip to wait for a new protocol frame.

Serial Protocol

The serial protocol controls the data transfer between the host controller and the CANopen Gateway Chip.

Byte 0	Byte 1	Byte 2..n	
Command	DataLen	DataByte0	DataByte1

Command: The Command Byte describes the command or the content of the data bytes.

DataLen: If DataLen is smaller than 0x80 DataLen gives the number of data bytes to be transmitted in the same telegram. If DataLen is equal to or greater than 0x80 specialcommand extension is activated (See command spec)

Each telegram must be answered with a telegram using the same command byte.

Serial Protocol Commands

The serial protocol supports the following commands.

Cmd Byte	Data Len	Telegram Flow	Description
0x01	0	G -> H	Boot-Up Message indicates that the Gateway has started
0x02	0	H -> G	Enable CANopen interface Starts the CANopen interface within the Gateway controller
0x02	0x81	H -> G	Enable CANopen interface Optional Start cmd for digital only mode
0x20		H -> G	Write directly to CAN open dictionary object
0x21	0	H -> G	Request reading directly from CAN open dictionary object
0x21		G -> H	Answer reading directly from CAN open dictionary object
0x30	0..8	H -> G	Write transmit PDO1 data
0x31	0..8	H -> G	Write transmit PDO2 data
0x40	0	H -> G	Request read receive PDO1 data
0x40	0..8	G -> H	Answer read receive PDO1 data
0x50	0	H -> G	Request NMT state
0x50	1	G -> H	Answer NMT state
0x51	8	G -> H	Report Emergency

Telegram Flow:

H -> G Telegram flow is from Host Controller to Gateway Chip.

G -> H Telegram flow is from Gateway Chip to Host Controller.

0x01 : Boot Up Message

With the Boot Up message, the CO401GW1 chip indicates, that a boot up process occurred. The Chip transmits this message cyclically every 250 milli seconds and does not start the CANopen interface until the Host enables this with the "0x02 Enable CANopen" message. This enables the host to modify various settings in the object dictionary, before the CANopen interface is started.

Boot Up Message
(Message from CO401GW1 to host)

Byte	
0	1
0x01	0x00

0x02 : Enable CANopen interface

With this message the Host starts the CANopen interface of the CO401GW1 chip. The CO401GW1 answers with the same message to indicate the correct processing of this command.

Enable CANopen interface standard mode
(Message from Host to Gateway)

Byte	
0	1
0x02	0x00

Enable CANopen interface alternate mode

This command is only supported for the digital only mode. In this case CAN-Identifiers:
280h + Node-Id is used for Transmit PDO5 additional digital inputs.
300h + Node-Id is used for Receive PDO5 additional digital outputs.

Note: This is not according to the CANopen draft standard.

(Message from Host to Gateway)

Byte	
0	1
0x02	0x81

Answer (from CO401GW1 to host)

Byte	
0	1
0x02	0x00

0x20 : Write to Object Dictionary

With this message the Host modifies the CANopen object dictionary data directly. The CO401GW1 answers with the same message type to indicate the correct processing of this command.

Write CANopen dictionary
(Message from Host to Gateway)

Byte							
0	1	2	3	4	5	6	
0x20	len	IL	IH	SI	D0	D1	Dn

Len 3 + number of data bytes

IL Index of object dictionary LOW byte

IH Index of object dictionary HIGH byte

SI Sub-Index of object dictionary

D0..Dn Data bytes to write to object dictionary

D0 (least significant byte)

Answer (from CO401GW1 to host)

Byte	
0	1
0x20	0x00

Example:

The Host wants to write 0x12345678 to object 1018.04 (Serial Number of Identity Object)

The required message is:

0x20 0x07 0x18 0x10 0x04 0x78 0x56 0x34 0x12

The CO401GW1 will answer with the message:

0x20 0x00

Note: The Gateway-Interface can only modify objects with Index greater than 0x3000 with exception that object 0x100B can be modified, but only if the CANopen Interface is not started.

0x21 : Read from Object Dictionary

With this message the Host can read data from the CANopen object dictionary. The CO401GW1 answers with the same message including the data.

Read CANopen dictionary
(Message from Host to Gateway)

Byte				
0	1	2	3	4
0x21	0x03	IL	IH	SI

IL Index of object dictionary LOW byte
IH Index of object dictionary HIGH byte
SI Sub-Index of object dictionary

Answer (from CO401GW1 to host)

Byte							
0	1	2	3	4	5	6	
0x21	len	IL	IH	SI	D0	D1	Dn

Len 3 + number of data bytes
IL Index of object dictionary LOW byte
IH Index of object dictionary HIGH byte
SI Sub-Index of object dictionary
D0..Dn Data bytes read from object dictionary
D0 (least significant byte)

Example:

The Host wants to read from object 1018.04 (Serial Number of Identity Object) The object keeps the value 0x12345678.

The required message is:

0x21 0x03 0x18 0x10 0x04

The CO401GW1 will return the data with the message:

0x21 0x07 0x18 0x10 0x04 0x78 0x56 0x34 0x12

0x3P : Write Transmit PDO Data

With this message the Host modifies the Transmit PDO data. The CO401GW1 answers with the same message type to indicate the correct processing of this command. The number of data bytes should always match with the size of the mapped PDO objects.

Write Transmit PDO data
(Message from Host to Gateway)

Byte							
0	1	2	3	4	5	6	
0x3P	Len	D0	D1	D2	D3	D4	Dn

P number of transmit PDO to write to
0: TPDO1, 1: TPDO2, 2: TPDO3 ...

Len number of data bytes to write to PDO
D0..Dn Data bytes to write to the PDO

Answer (from CO401GW1 to host)

Byte	
0	1
0x3P	0x00

The CO401GW1 controller modifies not only the transmit PDO data, but also the related objects of the object dictionary. This guarantees data consistence also in case of SDO transfer.

Example:

There are three single bytes mapped in transmit PDO1. The Host wants to write 0x123456 to this PDO.

The required message is:

0x30 0x03 0x12 0x34 0x56

There are one byte and two integers mapped in transmit PDO1. The Host wants to write 0x12 to the byte and 0x3456 and 0x7890 to the integers of this PDO.

The required message is:

0x30 0x03 0x12 0x56 0x34 0x90 0x78

For both examples, the CO401GW1 will answer with the message:

0x30 0x00

Note:

The arrangement of the bytes, transferred with the gateway message is the same that will be transferred with the transmit PDO. It should match with the byte arrangement of the objects that are mapped in the PDO.

0x4P : Read Receive PDO Data

With this message the Host can read the data received with receive PDO. The CO401GW1 answers with the data. The number of data bytes matches with the size of the mapped PDO objects.

Read Receive PDO Data
(Message from Host to Gateway)

Byte	
0	1
0x4P	0

P number of transmit PDO to write to

Answer (from CO401GW1 to host)

Byte							
0	1	2	3	4	5	6	
0x4P	Len	D0	D1	D2	D3	D4	Dn

P number of transmit PDO to write to
0: RPDO1, 1: RPDO2, 2: RPDO3 ...

Len number of data bytes to write to PDO
D0..Dn Data bytes to write to the PDO

Example:

The CO401GW1 has received the RPDO0 with 4 mapped bytes and the following data bytes 0x12 0x34 0x56 0x78. The Host wants to read this PDO data.

The "request PDO data" message is:

0x40 0x00

The CO401GW1 will answer with the message:

0x40 0x04 0x12 0x34 0x56 0x78

Note:

The arrangement of the bytes, transferred with the gateway message is just the same that is received with the PDO data.

Note:

The transmission of received PDO data can be configured to automatic mode. In this case the Gateway chip will always send the PDO data frame, if it has received the related PDO from the CANopen network and the data has changed. See Object 0x2E00 for further details.

0x50 : Read NMT State

With this message the Host can read the current NMT state.

Read NMT state (Message from Host to Gateway)

Byte	
0	1
0x50	0

Answer (from CO401GW1 to host)

Byte		
0	1	2
0x50	0x01	NMT

NMT Current NMT state according to DS301

Example:

The Host wants to read the NMT state. The CANopen interface of the CO401GW1 is in preoperational state.

The "request NMT state" message is:

0x50 0x00

The CO401GW1 will answer with the message:

0x50 0x01 0x7F

0x51 : Report Emergency

With this message the CANopen Gateway reports each emergency message, that is transmitted to the CANopen Network also to the Host. The data of message to the Host is exactly the same as it is transmitted to the CANopen Network within the Emergency message.

Report Emergency (Message from Host to Gateway)

Byte									
0	1	2	3	4	5	6	7	8	9
51h	8	EL	EH	ER	F1	F2	F3	F4	F5

EL/EH Emergency Error Low-Byte / High Byte
(according to Draft Standard DS301)

ER Error Register (Object 1001h)

F1..F5 Manufacturer Specific Error Field

Answer (from host to CO401GW)

Byte	
0	1
0x51	0

Object Dictionary

The CO401-Gateway1 Controller keeps a complex object dictionary for CANopen I/O devices.

For detailed information about CANopen objects see additional brochure "Introduction to CANopen"

For the Object tables all values are shown in hexadecimal way.

For access types the following settings are valid

ro read only
wo write only
rw read and write access enabled

DS301: global Objects

Index	Sub-Index	Name	Acc.
0005	-	Dummy 8	ro
0006	-	Dummy 16	ro
0007	-	Dummy 32	ro
1000	-	Device Type	ro
1001	-	Error Register	ro
1002	-	Manufacturer Status Register	ro
1005	-	COB-ID Sync Identifier Sync Object	ro
1008	-	Device Name	ro
1009	-	Hardware Version	ro
100A	-	Software Version	ro
100B	-	Node Id *3)	-
100C	-	Guard Time	rw
100D	-	Life Time Factor	rw
100E	-	COB-ID Guard *3)	-
1010	-	Store Parameters *1)	wo
1011	-	Reload Default Parameter *1)	wo
1014	-	COB ID Emergency	rw
1015	-	Inhibit Time Emergency	rw
1017	-	Producer Heartbeat Time	rw
1018	0	Identity Object	ro
	1	Vendor ID	ro
	2	Product Code	ro
	3	Revision Number	ro
	4	Serial Number	ro
1029	0	Error Behavior	ro
	1	In case of bus errors	rw
	2	In case of output errors	rw
2000	-	Device Manufacturer *2)	ro
2101	-	System Configuration	ro
2102	-	Remapping Enabled Info	ro
2103	-	Enable Guarding Warning	rw
2110	-	Enable Boot Up Message	rw
2180	-	CAN Restart Time	rw

Index	Sub-Index	Name	Acc.
2E00	0	Gateway I/O Control *4)	ro
	1	Enable Hardware Digital In	ro
	2	Enable Hardware Analog In	ro
2E01	0	Gateway Transfer Control *4)	ro
	1	Auto Send Received PDOs	ro
	2	Auto Send NMT state	ro
	3	Report Emergencies	ro

Notes:

- *1) This object cannot be written to in operational device state.
Only use this command in preoperational device state, otherwise the Chip will answer requests with SDO abort telegrams.
- *2) This Objects shows "Frenzel + Berg" as visible string data type.
- *3) This objects are implemented but not accessible from CAN bus line. Description is added in order to give an easier understanding of the CO4031s functionality.
- This Object can be modified from the Host, using the SDO write protocol.

The data type entries Index 0005 to 0007 are implemented for compatibility reasons. They may be mapped to PDOs in order to define the appropriate space in the PDO.

For the read only objects following data is set:

Index	Sub.	Name	Value in Hex.
1000		Device Type	000F 0191 h
1018	0	Identity Object	03h
	1	Vendor ID	0000 0058 h
	2	Product Code	0140 1FFF h
	3	Revision Number	0 .. 0xFFFFFFFF
	4	Serial Nr.	Set through gateway
2101		System Configuration	Set according to the setting of the configuration input bits.

DS301: PDO Parameter/Mapping Objects

Description of PDO Parameter objects:

These Objects enable dynamic PDO mapping, variable identifier distribution for PDOs and setting of the transmission mode, inhibit and event times.

The setting of all parameters may be done in the device state "operational" as well as in "preoperational" state.

The CANopen Gateway Chip CO401GW1 supports 2 Receive PDOs and 2 Transmit PDOs.

Index	Sub-Index	Name	Acc.
14xx		Receive PDO Communication Parameter	
18xx		Transmit PDO Communication Parameter	
14xx 18xx	0	Communication Parameter Nr of SubIndex	ro
	1	COB-ID	rw
	2	Transmission Type	rw
	3	Inhibit Time (not used)	rw
	4	Reserved	rw
	5	Event Timer	rw
1400 1401 1404	0 .. 5	Receive RPDO1/RPDO2 Communication Parameter *2)	rw
1800 1801 1804	0 .. 5	Transmit TPDO1/TPDO2 Communication Parameter *2)	rw
16xx		Receive PDO Mapping Parameter	
1Axx		Transmit PDO Mapping Parameter	
16xx 1Axx	0	Number of Mapped Objects in this PDO	rw
	1 to n	Mapped Object *1) (max. 8 objects mappable)	rw
1600 1601 1604		Receive RPDO1/ RPDO2 Mapping Parameter 1)2)	rw
1A00 1A01 1A04		Transmit TPDO1/ TPDO2 Mapping Parameter 1)2)	rw

Notes:

*1) This object can only be written to, if variable mapping is supported. See device configuration for further details.

*2) In Analog/Digital mixed mode RPDO2 and TPDO2 are supported
In digital only mode RPDO5 and TPDO5 are supported

DS401: I/O related Objects

The Chip supports two different modes and supports the related objects.

In Analog/Digital Mixed Mode the CANopen Gateway Chip CO401GW1 simulates a standard I/O device with 64 digital inputs, 64 digital outputs, 4 analog in- and 4 analog output channels.

In Digital Only Mode the CANopen Gateway Chip CO401GW1 simulates a standard I/O device with 128 digital inputs and 128 digital outputs. The analog objects are not supported.

DS401: Digital Input Objects

Index	Sub-Index	Name	Acc.
6000	0 to n	Read digital input 8 bit	ro
6002	0 to n	Polarity input 8-bit	rw
6005		Global interrupt enable	rw
6006	0 to n	Interrupt mask: any change	rw
6007	0 to n	Interrupt mask rising edge	rw
6008	0 to n	Interrupt mask falling edge	rw
6100	0 to n	Read digital input 16 bit	ro
6120	0 to n	Read digital input 32 bit	ro

DS401: Digital Output Objects

Index	Sub-Index	Name	Acc.
5200	-	Reset Output on Error Option	rw
6200	0 to n	Write Output 8 Bit	rw
6202	0 to n	Change Polarity Output 8 bit	rw
6206	0 to n	Error Mode Output	rw
6207	0 to n	Error State Output	rw
6300	0 to n	Write digital Output 16 bit	rw
6320	0 to n	Write digital Output 32 bit	rw

DS401: Analog Input Objects

Index	Sub-Index	Name	Acc.
6401	0 to n	Read Analog Input 16 Bit *2)	ro
6421	0 to n	Analog Input Interrupt Trigger	rw
6423		Analog Input global Interrupt Enable	rw
6424	0 to n	Analog Input Upper Limit	rw
6425	0 to n	Analog Input Lower Limit	rw
6426	0 to n	Analog Input Interrupt Delta	rw
6427	0 to n	Analog Input Interrupt Negative Delta	rw
6428	0 to n	Analog input interrupt positive delta	rw
6431	0 to n	Analog input offset integer	rw

DS401: Analog Output Objects

Index	Sub-Index	Name	Acc.
5201	-	Reset Output on Error Option	rw
6411	0 to n	Write Analog Output 16 Bit	ro
6443	0 to n	Error Mode Output	rw
6444	0 to n	Error Value Analog Output	rw

Description of Object Dictionary

The following list gives a description of all dictionary entries.

Index 0005 / 0006 / 0007

This object are implemented to enable reservation of data space in PDOs by mapping dummy entries.

Index	0005
Name	Dummy 8
Description	
Data Type	Unsigned 8
Access modes	RO
PDO Mapping	Yes
Value Range	-
Default Value	0

Index	0006
Name	Dummy 16
Description	-
Data Type	Unsigned 16
Access modes	RO
PDO Mapping	Yes
Value Range	-
Default Value	0

Index	0007
Name	Dummy 32
Description	-
Data Type	Unsigned 32
Access modes	RO
PDO Mapping	Yes
Value Range	-
Default Value	0

DS301: Global Objects**Index 1000 : Device Type**

Description of the device type. The Object gives the CiA device profile number and additionally the functionality of the device.

Index	1000h
Name	Device Type
Description	-
Data Type	Unsigned 32
Access modes	RO
PDO Mapping	No
Value Range	-
Default Value	0x00020194

Index 1001 : Error Register

This object holds an error of the device.

Index	1001h
Name	Error Register
Description	-
Data Type	Unsigned 8
Access modes	RO
PDO Mapping	Yes
Value Range	-
Default Value	-

The error register has the following structure

Bit	Meaning
0	Generic error. This bit is set, if any error is active
1	0
2	0
3	0
4	CAN bus or communication error
5	0
6	0
7	0

Index 1002 : Status Register

This object gives additional information for the device

Index	1002h
Name	Status Register
Description	-
Data Type	Unsigned 32
Access modes	RO
PDO Mapping	Yes
Value Range	-
Default Value	-

The status register bits have the following meaning

Bit	Meaning
0	Critical Application Emergency Pin EMY0# is active low
4	Uncritical Application Emergency Pin EMY1# is active low

Index 1005 : COB-ID Sync

Identifier of Can Object for the Synchronisation message. The CANopen-Chip may only operate in Sync consumer mode. Generating of Sync messages is not possible. Nevertheless is the Identifier for the Sync message programmable.

Index	1005h
Name	COB-ID Sync
Description	-
Data Type	Unsigned 32
Access modes	RO
PDO Mapping	No
Value Range	-
Default Value	-

Index 1008 : Device Name

This object shows the name of the device as visible string.

Index	1008h
Name	Device Name
Description	-
Data Type	Visible String
Access modes	RO
PDO Mapping	No
Value Range	The maximum string length is 20 characters
Default Value	CO401GW1

Index 1009 : Hardware Version

This object shows the Hardware Version as visible string.

Index	1009h
Name	Hardware Version
Description	-
Data Type	Visible String
Access modes	RO
PDO Mapping	No
Value Range	The maximum string length is 20 characters
Default Value	-

Index 100A : Software Version

This object shows the Software Version as visible string.

Index	100Ah
Name	Software Version
Description	-
Data Type	Visible String
Access modes	RO
PDO Mapping	No
Value Range	The maximum string length is 20 characters
Default Value	-

Index 100B : Node-ID

This object keeps the actual node Id. The Object is not represented in the object dictionary because of standard conforming reasons.

Index	100Bh
Name	Node ID
Description	-
Data Type	Unsigned 8
Access modes	Not accessible
PDO Mapping	No
Value Range	1 to 127
Default Value	See below

There are several modes to select a valid node ID.

Setting the configuration input bits ID0 to ID6 to any combination other than zero will take the configuration input setting of bits ID0 to ID6 as valid Node-ID.

Note:

Object 100B may be set after reset using the Gateway interface before the CANopen interface is enabled. This feature may be used to set a valid node ID without using DIP switches.

Index 100C : Guard Time

The objects at index 100Ch (Guard Time in milliseconds) and 100Dh (Life Time Factor) are used to implement the life guarding protocol. The Guard Time multiplied with the Life Time Factor gives the Life Time in milliseconds.

It is 0 (zero) if not used.

Index	100Ch
Name	Guard Time
Description	-
Data Type	Unsigned 16
Access modes	RW
PDO Mapping	No
Value Range	
Default Value	0

Index 100D : Life Time Factor

The objects at index 100Ch (Guard Time in milliseconds) and 100Dh (Life Time Factor) are used to implement the life guarding protocol. The Guard Time multiplied with the Life Time Factor gives the Life Time in milliseconds.

It is 0 (zero) if not used.

Index	100Dh
Name	Life Time Factor
Description	-
Data Type	Unsigned 16
Access modes	RW
PDO Mapping	No
Value Range	
Default Value	0

Index 1010 : Store Parameters

This object supports the saving of parameters in non-volatile memory. By read access the device provides information about its saving capabilities. Several parameter groups are distinguished:

Sub-Index 0 contains the largest Sub-Index that is supported.

Writing to Sub-Index 1 means that all parameters shall be stored on the device.

In order to avoid storage of parameters by mistake, storage is only executed when a specific signature

is written to the appropriate Sub-Index. (This means that the signature is transferred as data bytes 4 to 7 in the CAN message of the corresponding SDO protocol.

The signature is "save".

MSB		LSB	
e	v	a	s
65h	76h	61h	73h

On reception of the correct signature on sub-index 1 the device stores the parameters and then confirms the SDO transmission (initiate download response). If the storing failed, the device responds with an Abort SDO Transfer (abort code: 0606 0000 h).

If a wrong signature is written, the device refuses to store and responds with Abort SDO Transfer

(Abort code : 0800 002x h).

Index	1010h
Name	Store Parameters
Description	-
Data Type	Structure

Index	1010h Subindex 0
Name	Largest SubIndex supported
Description	-
Data Type	Unsigned char
Access modes	RO
PDO Mapping	No
Value Range	1
Default Value	1

Index	1010h Subindex 1
Name	Store All Parameters
Description	Writing to this object stores the dictionary to non-volatile memory.
Data Type	Unsigned 32
Access modes	RW
PDO Mapping	No
Value Range	Signature "save"
Default Value	-

By read access to object 1010h Subindex 1, the device responds with SDO data 00000001h indicating that storing of data is only done on command.

Note: Writing to this object is only allowed in preoperational mode.

If the save command is done after a restore procedure, a previously saved dictionary is deleted, so the chip will start with default data.

Index 1011 : Restore Default Parameters

With this object the default values of parameters according to the communication or device profile are restored. By read access the device provides information about its capabilities to restore these values.

Several parameter groups are distinguished:

Sub-Index 0 contains the largest Sub-Index that is supported.

Writing to Sub-Index 1 restores all parameters that can be restored.

In order to avoid the restoring of default parameters by mistake, restoring is only executed when a specific signature is written to the appropriate sub-index. (This means that the signature is transferred as data bytes 4 to 7 in the CAN message of the corresponding SDO protocol.

The signature is "load".

MSB		LSB	
d	a	o	l
64h	61h	6Fh	6Ch

On reception of the correct signature on sub-index 1 the device restores the parameters and then confirms the SDO transmission (initiate download response). If the storing failed, the device responds with an abort SDO transfer (abort code: 0606 0000h).

If a wrong signature is written, the device refuses to store and responds with Abort SDO Transfer

(Abort code : 0800 002x h).

The default values are set valid after the device is reset (reset node) or power cycled. If the device requires storing on command (see Object 1010h), the appropriate command has to be executed after the reset if the default parameters are to be stored permanently.

Index	1011h
Name	Restore Default Parameters
Description	-
Data Type	Structure

Index	1011h Subindex 0
Name	Largest SubIndex supported
Description	-
Data Type	Unsigned char
Access modes	RO
PDO Mapping	No
Value Range	1
Default Value	1

Index	1011h Subindex 1
Name	Restore All Parameters
Description	Writing to this object restores the default values to the dictionary.
Data Type	Unsigned 32
Access modes	RW
PDO Mapping	No
Value Range	Signature "load"
Default Value	-

By read access to object 1011h Subindex 1, the device responds with SDO data 00000001h indicating that restoring of default data is available.

Note Writing to this object is only allowed in preoperational mode.

Index 1014 : COB-ID Emergency

Identifier of Can Object for the emergency messages.

Index	1014h
Name	COB-ID Emergency
Description	-
Data Type	Unsigned 32
Access modes	RW
PDO Mapping	No
Value Range	-
Default Value	80h + Node-ID

Index 1015 : Inhibit Time Emergency

Inhibit Time for emergency messages. If the Inhibit Time is set to 0, inhibit delay is disabled. The Inhibit Time is a multiple of 100usec, but the CO401GW1 offers a maximum resolution of 1 millisecond.

Index	1015h
Name	Inhibit Time Emergency
Description	-
Data Type	Unsigned 16
Access modes	RW
PDO Mapping	No
Value Range	-
Default Value	0

Index 1017 : Producer Heartbeat Time

The producer heartbeat time defines the cycle time of the heartbeat. The producer heartbeat time is 0 if it not used. The time has to be a multiple of 1ms.

Index	1017h
Name	Producer Heartbeat Time
Description	-
Data Type	Unsigned 16
Access modes	RW
PDO Mapping	No
Value Range	-
Default Value	0

Note:

Either Heartbeat or node guarding may be allowed at the same time. Do not use both protocols at the same time.

See additional brochure for further information about heartbeat protocol.

Index 1018 : Identity Object

The object at index 1018h contains general information about the device and the manufacturer renzel + berg elektronik. It cannot be modified.

Index	1018h
Name	Identity Object
Description	-
Data Type	Structure

Index	1018h Subindex 0
Name	Largest SubIndex supported
Description	-
Data Type	Unsigned char
Access modes	RO
PDO Mapping	No
Value Range	-
Default Value	3

Index	1018h Subindex 1
Name	Vendor ID
Description	Registration Code of renzel + berg elektronik at the CiA
Data Type	Unsigned 32
Access modes	RO
PDO Mapping	No
Value Range	-
Default Value	58h

Index	1018h Subindex 2
Name	Product Code
Description	Internal Product Code for CO401GW1 at renzel + berg elektronik
Data Type	Unsigned 32
Access modes	RO
PDO Mapping	No
Value Range	-
Default Value	FF40 4003 h

Index	1018h Subindex 3
Name	Revision Code
Description	
Data Type	Unsigned 32
Access modes	RO
PDO Mapping	No
Value Range	-
Default Value	Revision of the device

Index	1018h Subindex 4
Name	Serial Number
Description	
Data Type	Unsigned 32
Access modes	RO
PDO Mapping	No
Value Range	-
Default Value	

This object may be set using the gateway interface in order to set a serial number to the device. Gateway access is only possible directly after reset until the CANopen interface is enabled with the "Enable CANopen interface" protocol.

Index 1029 : Error Behaviour

With object 1029 the CANopen chip can be configured to enter alternatively the preoperational or the stopped state or remain in the current state in case of a device failure. Device failures shall include the following communication errors:

Bus-off conditions of the CAN interface, Life guarding error, Serious device errors also can be caused by device internal failures.

The value of the Error Classes is as follows:

- 0 = pre-operational
(only if current state is operational)
- 1 = no state change
- 2 = stopped
- 3 .. 127 = reserved

Index	1029h
Name	Error Behaviour Object
Description	-
Data Type	Structure

Index	1029h Subindex 0
Name	Largest SubIndex supported
Description	-
Data Type	Unsigned char
Access modes	RO
PDO Mapping	No
Value Range	-
Default Value	2

Index	1029h Subindex 1
Name	Communication Error
Description	NMT state change in case of communication error
Data Type	Unsigned 8
Access modes	RW
PDO Mapping	No
Value Range	-
Default Value	00h

Index	1029h Subindex 2
Name	Application Error
Description	NMT state change in case of pin EMY0# is at low level
Data Type	Unsigned 8
Access modes	RW
PDO Mapping	No
Value Range	-
Default Value	00h

Index 2000 : Device Manufacturer

This Object shows "Frenzel + Berg" as visible string.

Index	2000h
Name	Device Manufacturer
Description	-
Data Type	Visible String
Access modes	RO
PDO Mapping	No
Value Range	-
Default Value	„Frenzel + Berg“

Index 2101 : System Configuration

This Object returns the operation mode of the CANopen-Chip. It represents the inverted Setting of the configuration input bits CFG0 to CFG3.

Index	2101h
Name	System Configuration
Description	-
Data Type	Unsigned 32
Access modes	RO
PDO Mapping	No
Value Range	-
Default Value	Depends on CFG0 to CFG3

Index 2102 : Remapping Enabled Info

This Object indicates whether the remapping of the PDOs is allowed or not. To disable remapping of the PDOs the object can be modified via Serial Host. For gateway applications, that use the PDO commands for data transfer it is strongly recommended to disable PDO remapping. This should be done before the CANopen interface is enabled.

0: Remapping is disabled
1..255: Remapping is enabled

Index	2102h
Name	Remapping Enabled Info
Description	-
Data Type	Unsigned 8
Access modes	RO
PDO Mapping	No
Value Range	-
Default Value	1 (remapping of PDOs enabled)

Index 2103 : Enabled Guarding Warning

This Object enables/disables transmission of emergency messages in case of a node guarding warning.

The condition of a guarding warning is met, if the time between two node guarding frames increases the guarding time given in object 100C independent of the setting of the life time (object 100D). The node guarding warning does not cause any NMT state change or switching the output pins to the error state. It is implemented to give the CANopen master an early information that the guarding interval has already exceeded the predefined value.

0 : Guarding Warning is disabled
1 : Guarding Warning is enabled

Index	2103h
Name	Enable Guarding Warning
Description	-
Data Type	Unsigned 8
Access modes	RO
PDO Mapping	No
Value Range	-
Default Value	0

Index 2110 : Enable Boot Up Message

This Object enables or disables sending of the boot up message. The boot up message is CAN object with the identifier of the node guarding object and only one data byte with value 0 (zero).

If object 2110h is set to 0 the boot up message is disabled otherwise it is enabled.

Index	2110h
Name	Enable Boot Up Message
Description	-
Data Type	Unsigned 8
Access modes	RW
PDO Mapping	No
Value Range	-
Default Value	1 (enabled)

Index 2180 : CAN Restart Time

This Object gives the restart time out for the CAN communication layer in case of bus off errors in milliseconds.

If the restart time is set to 0 automatic restart of the device in case of bus off is prohibited.

Index	2180h
Name	CAN Restart Time
Description	-
Data Type	Unsigned 16
Access modes	RW
PDO Mapping	No
Value Range	0 .. 50000
Default Value	1000 (restart after 1 second)

Index 2E00 : Gateway I/O Control

With object 2E00 the hardware I/O of the CANopen chip can be switched on or off.

If the chips internal hardware is enabled, it modifies directly the related objects. This objects cannot be used for gateway data in this case. For example if the digital input byte0 is enabled, the related object 0x6000.01 is read from the hardware and cannot be modified from the gateway protocol "write transmit PDO data".

Note: This objects can only be modified from gateway interface using the "write to object dictionary" protocol. They are read only for the CANopen network.

Index	2E00h
Name	Gateway I/O Control
Description	-
Data Type	Structure

Index	2E00h Subindex 0
Name	Largest SubIndex supported
Description	-
Data Type	Unsigned char
Access modes	RO
PDO Mapping	No
Value Range	-
Default Value	2

Index	2E00h Subindex 1
Name	Enable digital input bytes
Description	Each Bit Enables one digital input byte. Bit0 enables Byte0.
Data Type	Unsigned 8
Access modes	RO
PDO Mapping	No
Value Range	-
Default Value	FFh (Digital inputs enabled)

Index	2E00h Subindex 2
Name	Enable analog input bytes
Description	Each Bit Enables one analog input byte. Bit0 enables Channel0.
Data Type	Unsigned 8
Access modes	RO
PDO Mapping	No
Value Range	-
Default Value	FFh (Analog inputs enabled)

Index 2E01 : Gateway Transfer Control

With object 2E01 the CANopen chip can be configured to send various information to the gateway host, without the need of a request message.

For example if the "Auto Send Received PDOs" Object is set, the CANopen chip sends the data of a received PDO automatically to the gateway host, if a PDO with new data was received.

The Transmission of received PDO data to the gateway host is only performed, if the received PDO data has changed compared with the PDO data that have been sent to the gateway host with the last message.

Note: This objects can only be modified from gateway interface using the "write to object dictionary" protocol. They are read only for the CANopen network.

Index	2E01h
Name	Gateway Transfer Control
Description	-
Data Type	Structure

Index	2E01h Subindex 0
Name	Largest SubIndex supported
Description	-
Data Type	Unsigned char
Access modes	RO
PDO Mapping	No
Value Range	-
Default Value	3

Index	2E01h Subindex 1
Name	Auto Send Received PDO data
Description	If the bit is set, the data of a received PDO is automatically sent to the gateway host using the answer frame of the "read receive PDOP data" protocol. Each Bit represents the feature for one PDO. Bit0 : Controls Receive-PDO1 Bit1 : Controls Receive-PDO2 ...
Data Type	Unsigned 16
Access modes	RO
PDO Mapping	No
Value Range	-
Default Value	0000h (no automatic transfer)

Index	2E01h Subindex 2
Name	Auto Send NMT state
Description	If set to a value unequal 0 (zero), the NMT state is always reported to the gateway host, if it changes, or if the CANopen chip receives a NMT message from the CANopen network. For reporting the NMT state, the CANopen chip uses the answer frame of the "read NMT state" protocol.
Data Type	Unsigned 8
Access modes	RO
PDO Mapping	No
Value Range	-
Default Value	00h

Index	2E01h Subindex 3
Name	Report Emergencies
Description	If set to a value unequal 0 (zero), the CANopen chip reports all emergencies that are sent to the CANopen network to the gateway host using the "report emergency" protocol. The CO401GW1 reports both setting and resetting of emergency events.
Data Type	Unsigned 8
Access modes	RO
PDO Mapping	No
Value Range	-
Default Value	00h

DS301: PDO Parameter Objects

Communication Parameter Objects

The following table shows the communication parameter objects for Index 140x (Receive PDOs) and Index 180x (Transmit PDOs). The tables show Index 1400 as an example for all PDOs

The transmission type (sub-index 2) defines the mode for transmission / reception of the PDO. See table for detailed description of this entry.

Description of transmission type:

Type	PDO transmission				
	cyclic	acyclic	Sync related	Async.	Only on remote
0		X	X		
1-240	X		X		
241-251	Reserved				
252			X		X
253				X	X
254				X	
255				X	

Synchronous (transmission types 0-240 and 252) means that the transmission of the PDO shall be related to the SYNC object. Asynchronous means that the transmission of the PDO is not related to the SYNC object.

A transmission type of zero means that the message shall be transmitted synchronously with the SYNC object but not periodically but only in case of data change.

A value between 1 and 240 means that the PDO is transferred synchronously and cyclically, the transmission type indicating the number of SYNC signals, which are necessary to trigger PDO transmissions or receptions.

The transmission types 252 and 253 mean that the PDO is only transmitted on reception of a remote frame. At transmission type 252, the data is updated (but not sent) immediately after reception of the SYNC object. At transmission type 253 the data is updated at the reception of the remote frame. These values are only possible for transmit PDOs.

Transmission type 254 selects the CanEASY mode.

Transmission type 255 means, the application event is defined in the device profile. For receive PDOs the reception of a PDO will update the mapped data (normally the analog or digital outputs).

Sub-index 3h contains the inhibit time. This time is a minimum interval for PDO transmission. The value is defined as multiple of 100ms.

Sub-index 4h is reserved.

In mode 254/255 additionally an event time can be used for TPDO. If an event timer exists for a TPDO (value not equal to 0) the elapsed timer is considered to be an event. The event time is a multiple of 1 ms. This event will cause the transmission of this TPDO in addition to otherwise defined events.

The PDO communication parameter objects have the same structure for all PDOs. The following Objects are used.

Index	PDO
1400h	Receive PDO1
1401h	Receive PDO2 *1)
1404h	Receive PDO5 *2)
1800h	Transmit PDO1
1801h	Transmit PDO2 *1)
1804h	Transmit PDO5 *2)

*1) Analog/Digital Mixed Mode

*2) Digital only mode

Index	14xxh / 18xxh
Name	Receive PDO1 Communication Parameters
Description	-
Data Type	Structure

Index	14xxh / 18xxh Subindex 0
Name	Largest SubIndex supported
Description	-
Data Type	Unsigned 8
Access modes	RO
PDO Mapping	No
Value Range	-
Default Value	5

Index	14xxh / 18xxh Subindex 1
Name	COB-ID
Description	Identifier for CAN-Object for PDO1
Data Type	Unsigned 32
Access modes	RW
PDO Mapping	No
Value Range	-
Default Value	180h + Node-Id (for Index 1800) 280h + Node-Id (for Index 1801) 80000000h (for Index 1804) 200h + Node-Id (for Index 1400) 300h + Node-Id (for Index 1401) 80000000h (for Index 1404)

An Identifier of 80000000h means, that this PDO is disabled by default and must be enabled from the CANopen master by assigning a valid PDO ID.

Index	14xxh / 18xxh Subindex 2
Name	Transmission Type
Description	-
Data Type	Unsigned 8
Access modes	RW
PDO Mapping	No
Value Range	-
Default Value	0FFh

Index	14xxh / 18xxh Subindex 3
Name	Inhibit Time
Description	-
Data Type	Unsigned 16
Access modes	RW
PDO Mapping	No
Value Range	-
Default Value	0

Index	14xxh / 18xxh Subindex 4
Name	Reserved
Description	-
Data Type	-
Access modes	-
PDO Mapping	No
Value Range	-
Default Value	-

Index	14xxh / 18xxh Subindex 5
Name	Event Time
Description	-
Data Type	Unsigned 16
Access modes	RW
PDO Mapping	No
Value Range	-
Default Value	1000

PDO Mapping Objects

The following table shows the PDO Mapping Objects. The principle of PDO mapping is the same for all PDOs. The PDO Mapping table is the cross reference between the Object dictionary entries (for example the data of a digital output byte) and the data field inside an PDO data field (position in the data field of a CAN message for PDO transfer).

Subindex 0 determines the valid number of objects that have been mapped. The CANopen-Chip allows a maximum of 8 mapped objects for each PDO. For changing the PDO mapping first subindex 0 must be set to 0 (mapping is deactivated). Then the objects can be remapped. When a new object is mapped by writing a subindex between 1 and 8, the device may check whether the object specified by index /subindex exists. If the object does not exist or the object cannot be mapped, the SDO transfer will be aborted.

Subindexes 1 to 8 keep the pointers of the mapped objects as unsigned 32 values. The value is 0 if there is no mapped object. The structure for these pointers is as follows.

MSB		LSB	
Byte3	Byte2	Byte1	Byte0
Mapped index		Subindex	Length

Mapped Index and Subindex together are the Pointer to the Object dictionary data to be mapped at this location.

Length gives the length of the mapped object in bits.

The following mapping object uses index 1600 as an example for all mapping objects.

Index	160xh
Name	Receive PDO1 Mapping Parameters
Description	-
Data Type	Array

Index	160xh Subindex 0
Name	Largest SubIndex supported
Description	Number of mapped objects
Data Type	Unsigned 8
Access modes	RW
PDO Mapping	No
Value Range	-
Default Value	See table below

Index	160xh Subindex 1 to 8
Name	Mapped object
Description	
Data Type	Unsigned 32
Access modes	RW
PDO Mapping	No
Value Range	-
Default Value	See table below

Analog/Digital Mixed Mode / Receive PDOs

For the Analog/Digital Mixed Mode, the CANopen chip CO401GW1 uses the following default mapping entries receive PDO mapping:

Index	Entry	Explanation
Receive-PDO1 (digital outputs)		
1600.00	8	RPDO1: 8 mapped objects
1600.01	62000108h	Digital Output Byte0
1600.02	62000208h	Digital Output Byte1
1600.03	62000308h	Digital Output Byte2
1600.04	62000408h	Digital Output Byte3
1600.05	62000508h	Digital Output Byte4
1600.06	62000608h	Digital Output Byte5
1600.07	62000708h	Digital Output Byte6
1600.08	62000808h	Digital Output Byte7
Receive-PDO2 (analog outputs)		
1601.00	4	RPDO2: 4 mapped objects
1601.01	64110110h	Analog Output Integer 0
1601.02	64110210h	Analog Output Integer 1
1601.03	64110310h	Analog Output Integer 2
1601.04	64110410h	Analog Output Integer 3

Analog/Digital Mixed Mode / Transmit PDOs

For the Analog/Digital Mixed Mode, the CANopen chip CO401GW1 uses the following default mapping entries for transmit PDO mapping:

Index	Entry	Explanation
Transmit-PDO1 (digital inputs)		
1A00.00	8	TPDO1: 8 mapped objects
1A00.01	60000108h	Digital Input Byte0
1A00.02	60000208h	Digital Input Byte1
1A00.03	60000308h	Digital Input Byte2
1A00.04	60000408h	Digital Input Byte3
1A00.05	60000508h	Digital Input Byte4
1A00.06	60000608h	Digital Input Byte5
1A00.07	60000708h	Digital Input Byte6
1A00.08	60000808h	Digital Input Byte7
Transmit-PDO2 (analog inputs)		
1A01.00	4	TPDO2: 4 mapped objects
1A01.01	64010110h	Analog Input Integer 0
1A01.02	64010210h	Analog Input Integer 1
1A01.03	64010310h	Analog Input Integer 2
1A01.04	64010410h	Analog Input Integer 3

Most of the mapped objects are only memory locations for gateway features.

Digital Only Mode / Receive PDOs

For the Digital Only Mode, the CANopen chip CO401GW1 uses the following default mapping entries for receive PDO mapping:

Index	Entry	Explanation
Receive-PDO1 (digital outputs)		
1600.00	8	RPDO1: 8 mapped objects
1600.01	62000108h	Digital Output Byte0
1600.02	62000208h	Digital Output Byte1
1600.03	62000308h	Digital Output Byte2
1600.04	62000408h	Digital Output Byte3
1600.05	62000508h	Digital Output Byte4
1600.06	62000608h	Digital Output Byte5
1600.07	62000708h	Digital Output Byte6
1600.08	62000808h	Digital Output Byte7
Receive-PDO5 (digital outputs)		
1604.00	8	RPDO5: 8 mapped objects
1604.01	62000908h	Digital Output Byte8
1604.02	62000A08h	Digital Output Byte9
1604.03	62000B08h	Digital Output Byte10
1604.04	62000C08h	Digital Output Byte11
1604.05	62000D08h	Digital Output Byte12
1604.06	62000E08h	Digital Output Byte13
1604.07	62000F08h	Digital Output Byte14
1604.08	62001008h	Digital Output Byte15

Digital Only Mode / Transmit PDOs

For the Digital Only Mode, the CANopen chip CO401GW1 uses the following default mapping entries for transmit PDO mapping:

Index	Entry	Explanation
Transmit-PDO1 (digital inputs)		
1A00.00	8	TPDO1: 8 mapped objects
1A00.01	60000108h	Digital Input Byte0
1A00.02	60000208h	Digital Input Byte1
1A00.03	60000308h	Digital Input Byte2
1A00.04	60000408h	Digital Input Byte3
1A00.05	60000508h	Digital Input Byte4
1A00.06	60000608h	Digital Input Byte5
1A00.07	60000708h	Digital Input Byte6
1A00.08	60000808h	Digital Input Byte7
Transmit-PDO5 (digital inputs)		
1A04.00	8	TPDO5: 8 mapped objects
1A04.01	60000908h	Digital Input Byte8
1A04.02	60000A08h	Digital Input Byte9
1A04.03	60000B08h	Digital Input Byte10
1A04.04	60000C08h	Digital Input Byte11
1A04.05	60000D08h	Digital Input Byte12
1A04.06	60000E08h	Digital Input Byte13
1A04.07	60000F08h	Digital Input Byte14
1A04.08	60001008h	Digital Input Byte15

Most of the mapped objects are only memory locations for gateway features.

DS401: Digital Input Objects

The following objects are describing the functionality of the digital input lines of the CO401GW1

Index 6000 : Read Digital Input 8 Bit

This object represents the digital input bytes. The value of the input lines is written to this object.

Before writing the level of the input lines to object 6000, the input data is processed in the following way:

- 1) The digital input lines are active low. This means, the input level is inverted at first.

There is a maximum of 1 digital input byte that is controlled from hardware pins. The input port can be switched on or off using object 2E00.01. The rest of the digital input objects may be written from the gateway host. On the CANopen network side, the CO401GW1 is looked as a I/O chip with 64 input pins.

Index	6000h
Name	Digital Input 8 Bit
Description	-
Data Type	Array

Index	Subindex 0
Name	Nr of Subobjects
Description	
Data Type	Unsigned 8
Access modes	RO
PDO Mapping	No
Value Range	-
Default Value	8 (Number of digital input bytes)

Index	Subindex 1 to Nr of input bytes
Name	Digital Input 8 Bit Byte n
Description	
Data Type	Unsigned 8
Access modes	RO
PDO Mapping	Yes
Value Range	-
Default Value	-

Index 6100 : Read Digital Input 16 Bit

This object enables 16-Bit access to the digital input bytes. The Object addresses the same data area as object 6000 but using unsigned integer data type. See Index 6000 for further details.

Index 6120 : Read Digital Input 32 Bit

This object enables 32-Bit access to the digital input bytes. The Object addresses the same data area as object 6000 but using unsigned long data type. See Index 6000 for further details.

Index 6002 : Polarity Input 8 Bit

With this object, the digital inputs may be inverted. See also Index 6000 for additional information.

The polarity selections works only on the hardware controlled input objects.

Index	6002h
Name	Polarity Input 8 Bit
Description	-
Data Type	Array

Index	Subindex 0
Name	Nr of Subobjects
Description	
Data Type	Unsigned 8
Access modes	RO
PDO Mapping	No
Value Range	-
Default Value	8 (Number of digital input bytes)

Index	Subindex 1 to Nr of input bytes
Name	Polarity Input 8 Bit Byte n
Description	
Data Type	Unsigned 8
Access modes	RW
PDO Mapping	No
Value Range	-
Default Value	0

Index 6005 : Global Interrupt Enable

This object enables or disables globally the interrupt behaviour without changing the interrupt masks.

In event-driven mode the device transmits the input values depending on the interrupt masks in objects 6006h, 6007h, and 6008h and the PDO transmission type.

TRUE (1) global interrupt enabled
FALSE (0) global interrupt disabled

Index	6005h
Name	Global Interrupt Enable
Description	-
Data Type	Boolean
Access modes	RW
PDO Mapping	No
Value Range	-
Default Value	TRUE

Index 6006 : Interrupt Mask Any Change

This object determines, which input lines shall activate an interrupt by any change of the input line. Both negative and positive edge will cause an interrupt, if enabled.

An interrupt will cause a PDO transmission in case of event driven transmission mode.

1 = interrupt enabled
0 = interrupt disabled

Index	6006h
Name	Interrupt Mask any change
Description	-
Data Type	Array

Index	Subindex 0
Name	Nr of Subobjects
Description	
Data Type	Unsigned 8
Access modes	RO
PDO Mapping	No
Value Range	-
Default Value	Number of digital input bytes

Index	Subindex 1 to Nr of input bytes
Name	Interrupt Mask any change
Description	
Data Type	Unsigned 8
Access modes	RW
PDO Mapping	No
Value Range	-
Default Value	0FFh (interrupt enabled)

Index 6007 : Interrupt Mask Low to High

This object has the same structure and behaviour as object 6006h but will cause interrupts only on rising edge of object index 6000. Note that input lines are active low, so rising edge of input data (object 6000) means falling edge of input port line.

Default value is 0.

Index 6008 : Interrupt Mask High to Low

This object has the same structure and behaviour as object 6006h but will cause interrupts only on falling edge of object index 6000. Note that input lines are active low, so falling edge of input data (object 6000) means rising edge of input port line.

Default value is 0.

DS401: Digital Output Objects

The following objects are describing the functionality of the digital output lines of the CO401GW1. The CO401GW1 supports only 8bit access.

Index 5200 : Output Reset on Error Option

This Object selects the function for error handling if a critical error is detected.

If the value is 0, the Outputs objects 6200.xx will keep unchanged. The ports will be set to their error state given in object 6207 as long as the error is active. If error ends, the outputs will return to values of the output object 6200h.

If the value is 1, the Outputs error handling depends on the objects 6206h and 6207h and the output object 6200 will be overwritten with the error output state according to objects 6206 and 6207.

Index	5200h
Name	Output Reset on Error Option
Description	-
Data Type	Unsigned 8
Access modes	RW
PDO Mapping	No
Value Range	-
Default Value	1

Index 6200 : Write to Digital Output

With object 6200, the digital outputs of the CO401GW1 can be written to. Before writing to the output ports, the value of the bitmap of object 6200 is processed with object 6202 (Change polarity output 8 bit) and the inverted. (Output port bits of the CO401GW1 device are active low)

There is only 1 digital hardware output byte. The received PDO data for this output is written to the port pins and additionally available for the gateway host. On the CANopen network side, the CO401GW1 is looked as a I/O chip with 64 output pins.

Index	6200h
Name	Write to digital output
Description	-
Data Type	Array

Index	Subindex 0
Name	
Description	Number of mapped objects
Data Type	Unsigned 8
Access modes	RO
PDO Mapping	NO
Value Range	-
Default Value	8 (Number of digital output bytes)

Index	Subindex 1 to Nr of output bytes
Name	Write to digital output
Description	
Data Type	Unsigned 8
Access modes	WO
PDO Mapping	YES
Value Range	-
Default Value	0

Index 6300 : Write Digital Output 16 Bit

This object enables 16-Bit access to the digital output bytes. The Object addresses the same data area as object 6200 but using unsigned integer data type. See Index 6200 for further details.

Index 6320 : Write Digital Output 32 Bit

This object enables 32-Bit access to the digital output bytes. The Object addresses the same data area as object 6200 but using unsigned long data type. See Index 6200 for further details.

Index 6202 : Polarity Output 8 Bit

With this object, the digital outputs may be inverted. See also Index 6200 for additional information. The polarity selections works only on the hardware controlled output objects

Index	6202h
Name	Polarity Output 8 Bit
Description	-
Data Type	Array

Index	Subindex 0
Name	Nr of Subobjects
Description	
Data Type	Unsigned 8
Access modes	RO
PDO Mapping	No
Value Range	-
Default Value	8 Number of digital output bytes

Index	Subindex 1 to Nr of input bytes
Name	Polarity Output 8 Bit Byte n
Description	
Data Type	Unsigned 8
Access modes	RW
PDO Mapping	No
Value Range	-
Default Value	0

Index 6206 : Error Mode Output 8 Bit

This object indicates, whether an output is forced to a predefined value (given in object 6207) in case of a device error.

1 = Output will be forced to the value selected in object 6207

0 = Output will be unchanged even in case of an error condition.

Index	6206h
Name	Error Mode Output 8 Bit
Description	-
Data Type	Array

Index	Subindex 0
Name	Nr of Subobjects
Description	
Data Type	Unsigned 8
Access modes	RO
PDO Mapping	No
Value Range	-
Default Value	Number of digital output bytes

Index	Subindex 1 to Nr of input bytes
Name	Error Mode Output 8 Bit Byte n
Description	
Data Type	Unsigned 8
Access modes	RW
PDO Mapping	No
Value Range	-
Default Value	0FFh (Take error condition from object 6207)

Index 6207 : Error Value Output 8 Bit

This object selects the level the outputs are forced to in case of device error mode if the error mode (object 6206 is enabled)

1 = Output will be forced to active state

0 = Output will be forced to inactive state.

Note: Outputs of CO401GW1 are active low.

Index	6207h
Name	Error Value Output 8 Bit
Description	-
Data Type	Array

Index	Subindex 0
Name	Nr of Subobjects
Description	
Data Type	Unsigned 8
Access modes	RO
PDO Mapping	No
Value Range	-
Default Value	Number of digital output bytes

Index	Subindex 1 to Nr of input bytes
Name	Error Value Output 8 Bit Byte n
Description	
Data Type	Unsigned 8
Access modes	RW
PDO Mapping	No
Value Range	-
Default Value	0 (Inactive, high level)

DS401: Analog Input Objects

The following objects are describing the functionality of the analog input lines of the CO401GW1.

The CO401GW1 supports no hardware analog input lines. The analog input related objects are implemented for the use as gateway transfer memory. Additionally there are several objects implemented, to give the user the possibility of selecting several trigger conditions for CAN transfer of PDO messages.

This objects are only supported for Analog/Digital Mixed Mode.

Index 6401 : Read Analog Input 16 Bit

Object 6401, represents the value of the analog input channels using signed integer format.

The CO401GW1 supports no hardware analog input lines. The analog input related objects are implemented for the use as gateway transfer memory.

Index	6401h
Name	Read Analog Input
Description	-
Data Type	Array

Index	Subindex 0
Name	
Description	Number of mapped objects
Data Type	Signed 16
Access modes	RO
PDO Mapping	NO
Value Range	-
Default Value	4 (Number of analog input bytes)

Index	Subindex 1 to Nr of input lines
Name	Read Analog Input
Description	
Data Type	Signed 8
Access modes	RO
PDO Mapping	YES
Value Range	-
Default Value	-

Index 6421 : Analog Input Interrupt Trigger

Object 6421 selects the event that shall cause a transmission interrupt for the selected analog channel.

There is one Subindex for each channel to enable individual setting according to application requirements.

Table of possible Trigger Conditions:

Bit Nr	Interrupt Trigger Selection
0	Input voltage greater than Upper Limit
1	Input voltage less than Lower Limit
2	Input changed by more than Delta
3	Input reduced more than Negative Delta
4	Input increased more than Positive Delta
5 to 7	Reserved (must be forced to zero)

Index	6421h
Name	Analog Input Interrupt Trigger
Description	-
Data Type	Array

Index	Subindex 0
Name	
Description	Number of mapped objects
Data Type	Unsigned 8
Access modes	RO
PDO Mapping	NO
Value Range	-
Default Value	Number of analog input lines

Index	Subindex 1 to Nr of input lines
Name	Analog Input Interrupt Trigger
Description	Selects trigger condition
Data Type	Unsigned 8 (See Table of Trigger Conditions)
Access modes	RW
PDO Mapping	No
Value Range	-
Default Value	7

Index 6423 : Analog Input Interrupt Enable

This object enables or disables globally the interrupt behaviour without changing the interrupt masks.

The interrupt is disabled by default, in order to avoid transmission of analog input values.

TRUE (1)= global interrupt enabled
FALSE (0)= global interrupt disabled

Index	6423h
Name	Analog Input Interrupt Enable
Description	-
Data Type	Boolean
Access modes	RW
PDO Mapping	No
Value Range	-
Default Value	FALSE

Index 6424/5/6/7/8 : Analog Input Interrupt Limits

These objects keep the Limits for generation of interrupts. All objects have the same structure.

The function of the interrupt limit is only enabled, if the corresponding bit of object 6421 is set.

All values of limit parameters are signed 32. So the user must take care not to exceed the range of the input data objects.

Object	Object Name and Function
6424	Analog Input Upper Limit Generate interrupt if input voltage is greater than Upper Limit (6424)
6425	Analog Input Lower Limit Generate interrupt if input voltage is less than Lower Limit (6425)
6426	Analog Input Interrupt Delta Generate interrupt if input voltage changed by more than Interrupt Delta
6427	Analog Input Negative Delta Generate interrupt if input voltage reduced by more than Negative Delta
6428	Analog Input Positive Delta Generate interrupt if input voltage increased by more than Positive Delta

Index	6424/5/6/7/8/9
Name	See table above
Description	-
Data Type	Array

Index	Subindex 0
Name	
Description	Number of mapped objects
Data Type	Unsigned 8
Access modes	RO
PDO Mapping	NO
Value Range	-
Default Value	Number of analog input lines

Index	Subindex 1 to Nr of input lines
Name	See table above
Description	
Data Type	Integer 32
Access modes	RW
PDO Mapping	No
Value Range	-
Default Value	0

Index 6431 : Analog Input Offset

Object 6431 adds an offset value to the analog input data object (6401).

The normal input scaling for analog data object 6401 considers conversion of negative input voltages (input amplifier must shift to positive voltages because input port pin is 0 to 5V only) by placing the zero point (of data) to 2.5V. (middle of input voltage range)

If application requires only positive input values an offset may be add with object 6431, in order to adjust the zero point for data to an input voltage of 0V. For 8 Bit analog conversion (object 6400) the offset value (object 6431) must be 80h. For 16 Bit analog conversion (object 6401) the offset value must be set to 8000h.

Index	6431h
Name	Analog Input Offset
Description	-
Data Type	Array

Index	Subindex 0
Name	
Description	Number of mapped objects
Data Type	Unsigned 8
Access modes	RO
PDO Mapping	NO
Value Range	-
Default Value	Number of analog input lines

Index	Subindex 1 to Nr of input lines
Name	Analog Input Offset
Description	
Data Type	Signed 32
Access modes	RW
PDO Mapping	No
Value Range	-
Default Value	0

DS401: Analog Output Objects

The following objects are describing the functionality of the analog output lines of the CO401GW1.

The CO401GW1 supports no hardware analog output lines. The analog output related objects are implemented for the use as gateway transfer memory. Additionally there are several objects implemented, to give the user the possibility of special reactions in case of emergencies.

This objects are only supported for Analog/Digital Mixed Mode.

Index 5201 : Output Reset on Error Option

This Object selects the function for error handling if a critical error is detected. This gives the user the possibility of special reactions in case of emergencies.

If the value is 0, the Output objects will keep unchanged.

If the value is 1, the Outputs objects will be set to their error levels according to objects 6443 and 6444.

Index	5201h
Name	Output Reset on Error Option
Description	-
Data Type	Unsigned 8
Access modes	RW
PDO Mapping	No
Value Range	-
Default Value	1

Index 6411 : Write Analog Output 16 Bit

Object 6411, represents the value of the analog output channels using signed integer format.

The CO401GW1 supports no hardware analog output lines. The analog output related objects are implemented for the use as gateway transfer memory.

Index	6411h
Name	Write Analog Output
Description	-
Data Type	Array

Index	Subindex 0
Name	
Description	Number of mapped objects
Data Type	Signed 16
Access modes	RO
PDO Mapping	NO
Value Range	-
Default Value	4 Number of analog Output bytes

Index	Subindex 1 to Nr of input lines
Name	Read Analog Input
Description	
Data Type	Signed 8
Access modes	RO
PDO Mapping	YES
Value Range	-
Default Value	-

Index 6443 : Error Mode Analog Output

This object indicates, whether an analog output is forced to a predefined value (given in object 6444) in case of a device error.

- 1 = Output will be forced to the value selected in object 6444
- 0 = Output will be unchanged even in case of an error condition.

Index	6443h
Name	Error Mode Analog Output
Description	-
Data Type	Array

Index	Subindex 0
Name	Nr of Subobjects
Description	
Data Type	Unsigned 8
Access modes	RO
PDO Mapping	No
Value Range	-
Default Value	Number of analog outputs

Index	Subindex 1 to Nr of analog output
Name	Error Mode Analog Output
Description	
Data Type	Unsigned 8
Access modes	RW
PDO Mapping	No
Value Range	-
Default Value	01h (Take error condition from object 6444)

Index 6444 : Error Value Analog Output

This object selects the level the outputs are forced to in case of device error (if the error mode object 6433 is enabled)

- 1 = Output will be forced to active state
 - 0 = Output will be forced to inactive state.
- Note: Outputs of CO401GW1 are active low.

Index	6444h
Name	Error Value Analog Output
Description	-
Data Type	Array

Index	Subindex 0
Name	Nr of Subobjects
Description	
Data Type	Unsigned 8
Access modes	RO
PDO Mapping	No
Value Range	-
Default Value	Number of analog outputs

Index	Subindex 1 to Nr of analog output
Name	Error Value Analog Output
Description	
Data Type	Signed 32
Access modes	RW
PDO Mapping	No
Value Range	-
Default Value	0

Emergency Messages

The CO401GW1 supports several emergency messages. For all emergencies the same structure is used:

Byte							
0	1	2	3	4	5	6	7
EMY-Code		1001	0	CO40xx-Code			

EMY-Code: Emergency-Error-Code according to DS301
 1001: Content of Object 1001
 CO40xx-Code: Emergency-Error-Code as unsigned 32 value

CO40xx-Code (hex)	May change		Description
	NMT	I/O	
8000 0000	X	X	CAN bus is bus off
4000 0000			CAN bus in error warning state
2000 0000			Node guarding warning
3000 0000	X	X	Life guarding error
0000 0001	X	X	Critical application error detected
0000 0010			Uncritical application error detected

Emergency 2000 0000 (Node guarding warning) must be enabled with object 2103.

If more than one error is active at the same time, the bitmap of the CO40xx-Codes for all active errors are combined with a logical or conjunction.

Some of the emergencies may cause a NMT state change and/or may force the output pins to the error state. This behaviour depends on the setting of object 1029.

The ID for emergency transmission is fixed to:

0x80 + \$NodeID.

List of emergency messages:

Node-Guarding Warning							
30	81	01	00	00	00	00	20

This warning occurs, if the masters fails to transmit the guarding remote frame within the specified Guard Time object 100C and if transmission is enabled in object 2103

Life-Guarding Error							
30	81	01	00	00	00	00	30

This error occurs, if the masters fails to transmit the guarding remote frame within the specified Life Time (Guard Time object 100C multiplied with Life Time Factor object 100D)

Application Emergency 0 (critical error)							
10	23	01	00	01	00	00	00

This error occurs, if the output overload interrupt input pin (EMY0# pin 43) is active low.

Application Emergency 1 (uncritical error)							
00	10	01	00	10	00	00	00

This error occurs, if the output overload interrupt input pin (EMY1# pin 44) is active low.

CAN Bus in Error Warning state							
00	81	01	00	00	00	00	40

This error occurs, if the chips internal CAN module is in error warning state.

Return from CAN Bus OFF							
40	81	01	00	00	00	00	C0

This message indicates a return from Bus OFF state.

Absolute Maximum Ratings

Stresses greater than those listed parameters may cause permanent damage to the device. Functional operation should be restricted to recommended operation conditions. Exposure to absolute maximum rating conditions for extended times may affect reliability.

Parameter	Symbol	Rated Value		Units	Remarks
		Min.	Max.		
Power supply voltage	VCC	VSS - 0.3	VSS + 6.0	V	
Input voltage	Vi	VSS - 0.3	VSS + 6.0	V	Vi < VCC + 0.3V
Output voltage	Vo	VSS - 0.3	VSS + 6.0	V	Vo < VCC + 0.3V
L level maximum output current	IOLMAX		15	mA	Time < 20 msec
L level maximum output current	IOL		4	mA	
H level maximum output current	IOHMAX		15	mA	Time < 20 msec
H level maximum output current	IOH		4	mA	
Maximum Power dissipation	P _{MAX}		300	mW	
Operating temperature	T _A	-40	+85	°C	CO401GW1A
	T _A	-40	+105	°C	CO401GW1AE
Storing temperature	T _A	-55	+150	°C	

Recommended Operation Conditions and Characteristics

Functional operation should be restricted to recommended operation conditions.

Parameter	Symbol	Rated Value			Units	Remarks
		Min.	Typ.	Max.		
Power supply voltage	VCC	4.5	5.0	5.5	V	
Power supply current	I _{CC}		40		mA	All inputs V _{IL} or V _{IH} All outputs open
Input H voltage	V _{IH}	0.8 * VCC		VCC + 0.3	V	
Input L voltage	V _{IL}	VSS - 0.3		0.2 * VCC	V	
Output H voltage	V _{OH}	VCC - 0.5			V	I _{OH} = -4.0 mA
Output L voltage	V _{OL}			0.4	V	I _{OL} = 4.0 mA
Input leakage current	I _{LKC}	-5		5	uA	
Crystal frequency	f _{osc}		4		MHz	
Reset pulse width	t _{res}	10			us	
Power on rise time	t _{RESLH}	0.05		30	ms	
Maximum CANopen Delay Gateway update to bus telegram	t _{DITB}	0.05	1	3	ms	No additional bus distribution delay
Maximum CANopen Delay bus telegram to start of gateway transfer	t _{DBTO}	0.05	1	3	ms	
Maximum Power dissipation	P _{MAX}			300	mW	
Operating temperature	T _A	-40		+85	°C	CO401GW1A
	T _A	-40		+105	°C	CO401GW1AE

Package Dimension

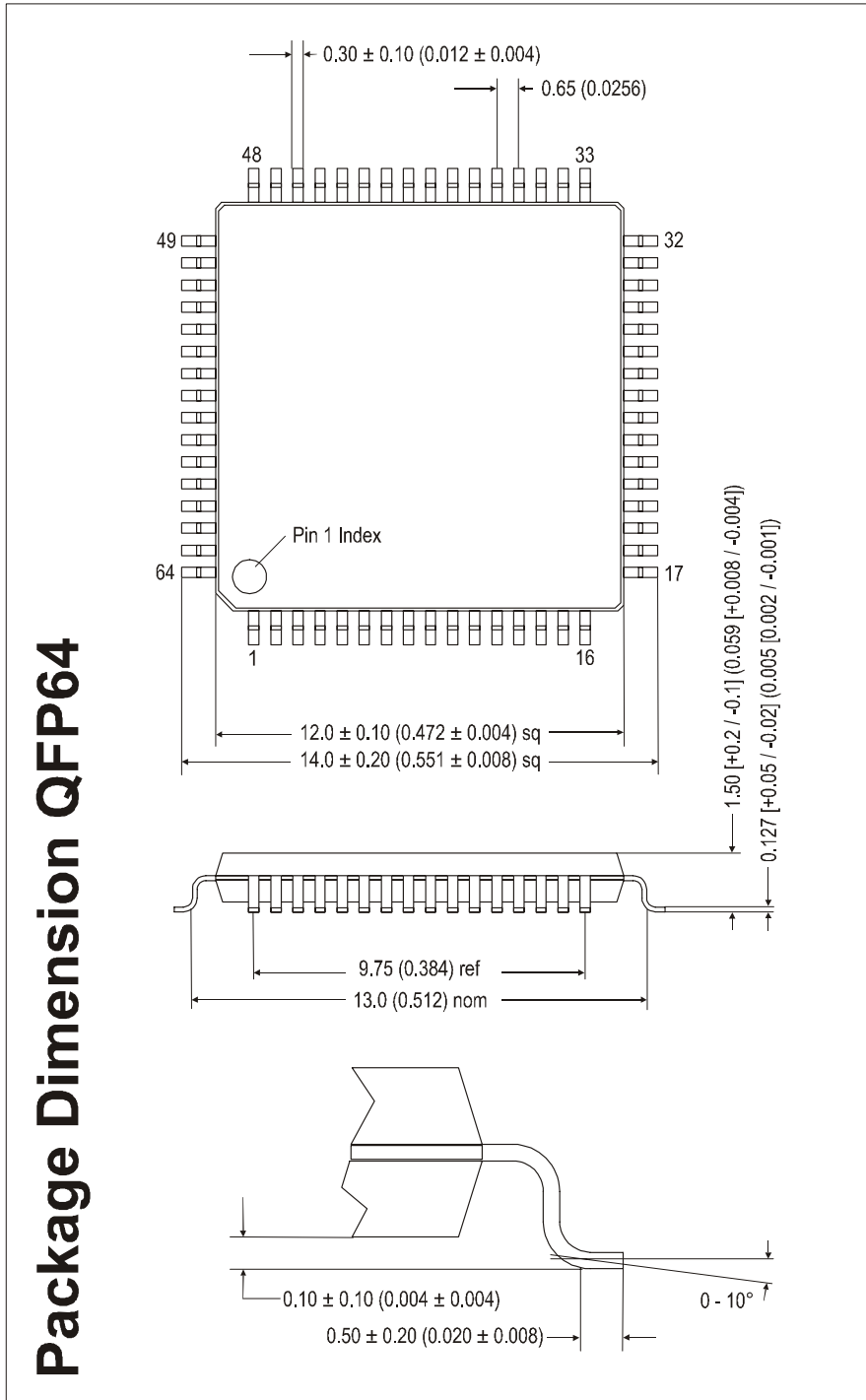

Revision History

Version	Date of Change	Changes
1.00	July/24/2002	First version
1.01	July/29/2002	Object 2102 (remapping enabled info) added
1.02	Nov/15/2002	CFG0 is used to enable/disable the digital input lines
1.15	July/25/2003	New operation mode (Digital Only Mode) is implemented. The configuration is done with CFG1. Additional Object 2103 Default value of object 2180 changed from 0 to 1000
1.22	Nov/20/2003	New operation mode Digital only mode can be set to default Identifier 280h+NodeId to TPDO5 and 300h+NodeId to RPDO5 using the optional start command
1.31	Dez/18/2003	Default Identifier for PDO5 set to CiA-default PDO-ID reserved for PDO2. (only supported for: digital only mode)
1.31 R 4	Feb/12/2007	Some data sheet corrections
1.42	May/16/2007	1) Length control to SDO string data transfer added. 2) Bugfix: CAN baud rate 10 kHz is working now 3) Bugfix: Node guarding process is only started by a received remote frame with the guarding COB-ID if the life time factor is set to a value != 0 4) Bugfix: Serial telegram for reading object dictionary corrected. Index and sub index is inserted into answer telegram correctly
1.42 R 1	July/05/2007	Some data sheet corrections

Table of Content

<p>General Description.....1</p> <p>Features.....1</p> <p>Applications1</p> <p>CANopen Features1</p> <p>Ordering Information.....1</p> <p>Pin Assignment.....2</p> <p>Pin Listing2</p> <p>Pin Listing continued2</p> <p>Pin Description3</p> <p>IN0 to IN7: Digital Input Pins.....3</p> <p>OUT0 to OUT7: Digital Output Pins3</p> <p>EMY0# / EMY1#: Emergency Input3</p> <p>CFG0/R: Configuration input / Run-LED.....3</p> <p>CFG1/E: Configuration input / Error-LED.....3</p> <p>CFG2/WD: Configuration input / watchdog output.....3</p> <p>CANRX, CANTX: CAN interface pins3</p> <p>RSRXD, RSTXD: RS232 interface pins.....3</p> <p>RES#: Reset input pin4</p> <p>X0, X1: Crystal oscillator input.....4</p> <p>BD0 to BD2: CAN baud rate configuration bits4</p> <p>RSBD0 to RSBD2: Serial baud rate configuration bits.4</p> <p>ID0 to ID7: CANopen identifier selection bits4</p> <p>SERNO: Silicon Serial Number Input.....4</p> <p>VCC, AVCC, VSS, AVSS: Power Supply Pins4</p> <p>CF: Filter Capacitor input.....4</p> <p>AVREF: Reference Voltage for A/D Converter4</p> <p>Handling the Device4</p> <p>Preventing latch up.....4</p> <p>Handling unused Pins.....4</p> <p>Input / output pins4</p> <p>Power Supply Pins.....4</p> <p>Power Supply for A/D converter4</p> <p>Pull up/down resistors.....4</p> <p>In Circuit programming5</p>	<p>Device Configuration 6</p> <p>CAN Identifier 6</p> <p>CAN baud rate 6</p> <p>Serial baud rate..... 6</p> <p>Device Configuration Pins 6</p> <p>Asynchronous Serial PDO Interface..... 7</p> <p>Serial Protocol 7</p> <p>Serial Protocol Commands..... 7</p> <p>0x01 : Boot Up Message 8</p> <p>0x02 : Enable CANopen interface 8</p> <p>0x20 : Write to Object Dictionary 8</p> <p>0x21 : Read from Object Dictionary..... 9</p> <p>0x3P : Write Transmit PDO Data 9</p> <p>0x4P : Read Receive PDO Data 10</p> <p>0x50 : Read NMT State..... 10</p> <p>0x51 : Report Emergency..... 10</p> <p>Object Dictionary..... 11</p> <p>DS301: global Objects..... 11</p> <p>DS301: PDO Parameter/Mapping Objects 12</p> <p>DS401: I/O related Objects 12</p> <p>DS401: Digital Input Objects 12</p> <p>DS401: Digital Output Objects 12</p> <p>DS401: Analog Input Objects 12</p> <p>DS401: Analog Output Objects 13</p> <p>Description of Object Dictionary..... 13</p> <p>Index 0005 / 0006 / 0007..... 13</p> <p>DS301: Global Objects..... 13</p> <p>Index 1000 : Device Type..... 13</p> <p>Index 1001 : Error Register 13</p> <p>Index 1002 : Status Register 14</p> <p>Index 1005 : COB-ID Sync..... 14</p> <p>Index 1008 : Device Name 14</p> <p>Index 1009 : Hardware Version..... 14</p> <p>Index 100A : Software Version..... 14</p>
--	--

Index 100B : Node-ID	15	Index 6401 : Read Analog Input 16 Bit.....	30
Index 100C : Guard Time	15	Index 6421 : Analog Input Interrupt Trigger.....	31
Index 100D : Life Time Factor	15	Index 6423 : Analog Input Interrupt Enable	31
Index 1010 : Store Parameters.....	16	Index 6424/5/6/7/8 : Analog Input Interrupt Limits....	32
Index 1011 : Restore Default Parameters.....	16	Index 6431 : Analog Input Offset.....	32
Index 1014 : COB-ID Emergency	17	DS401: Analog Output Objects	33
Index 1015 : Inhibit Time Emergency	17	Index 5201 : Output Reset on Error Option	33
Index 1017 : Producer Heartbeat Time.....	18	Index 6411 : Write Analog Output 16 Bit	33
Index 1018 : Identity Object.....	18	Index 6443 : Error Mode Analog Output.....	34
Index 1029 : Error Behaviour	19	Index 6444 : Error Value Analog Output.....	34
Index 2000 : Device Manufacturer	19	Emergency Messages	35
Index 2101 : System Configuration.....	19	Absolute Maximum Ratings	36
Index 2102 : Remapping Enabled Info.....	20	Recommended Operation Conditions and	
Index 2103 : Enabled Guarding Warning.....	20	Characteristics	36
Index 2110 : Enable Boot Up Message	20	Package Dimension	37
Index 2180 : CAN Restart Time.....	20	Typical Application	38
Index 2E00 : Gateway I/O Control	21	Revision History	39
Index 2E01 : Gateway Transfer Control.....	21	Table of Content	40
DS301: PDO Parameter Objects	22		
Communication Parameter Objects	22		
PDO Mapping Objects	24		
DS401: Digital Input Objects.....	26		
Index 6000 : Read Digital Input 8 Bit	26		
Index 6100 : Read Digital Input 16 Bit	26		
Index 6120 : Read Digital Input 32 Bit	26		
Index 6002 : Polarity Input 8 Bit.....	26		
Index 6005 : Global Interrupt Enable	27		
Index 6006 : Interrupt Mask Any Change	27		
Index 6007 : Interrupt Mask Low to High	27		
Index 6008 : Interrupt Mask High to Low	27		
DS401: Digital Output Objects.....	28		
Index 5200 : Output Reset on Error Option	28		
Index 6200 : Write to Digital Output.....	28		
Index 6300 : Write Digital Output 16 Bit.....	28		
Index 6320 : Write Digital Output 32 Bit.....	28		
Index 6202 : Polarity Output 8 Bit	29		
Index 6206 : Error Mode Output 8 Bit	29		
Index 6207 : Error Value Output 8 Bit	30		
DS401: Analog Input Objects.....	30		