

ROTATION TABLE

FRT 1000/H/C/FPA - 25000/H/C/FPA

/ Max. load capacity from 1-25 t
(2204.6-55115.6 lb)

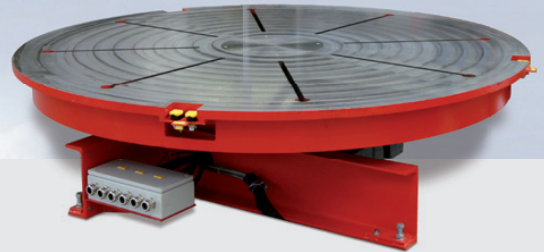

/ Horizontal rotation tables are universal applicable for mechanized welding applications as well as for precise positioning of work pieces.

STANDARD EQUIPMENT

- / Face-plate with concentric circular markings
- / Anti-backlash device to minimize the face-plate run-out deflection max. 2 mm (0.08 in)
- / Table flatness within 0,25 mm (0.01 in)
- / Welding-current transfer 600 A via carbon brushes
- / Table rotation by AC-motor through worm reduction gears and spur gears
- / Control unit with inverter
- / Face-plate bearing diameter 675 mm (26.6 in)
- / Remote control with cable 8 m (315 in)
- / 4 pc. concrete anchor with M24 nut
- / 4 pc. levelling device (metal plates and screws)
- / I-kit encoder for rotation drive

FUNCTIONS

- / Forward/stop/reverse
- / Speed
- / Emergency stop

ACCESSORIES

- / I-kit limit switch 360° and actuating cam for rotation unit
- / I-kit slip ring assembly for heating system
- / System controller FPA 2003/FPA 9000
- / Chucks FGC, FSG, FMC
- / Mounting sets for chucks



/ Welding-current transfer



/ Optional connection socket for heating system

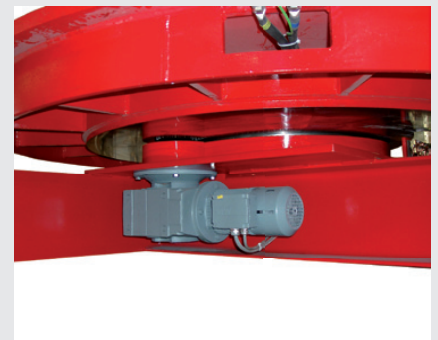

/ Anti-backlash device

TECHNICAL DATA

	FRT 1000/H/C/ FPA	FRT 2500/H/C/ FPA	FRT 5000/H/C/ FPA	FRT 10000/H/C/ FPA	FRT 15000/H/C/ FPA	FRT 20000/H/C/ FPA	FRT 25000/H/C/ FPA
Max. load capacity	1000 kg (2204.6 lb)	2500 kg (5511.6 lb)	5000 kg (11023.1 lb)	10000 kg (22046.2 lb)	15000 kg (33069.4 lb)	20000 kg (44092.5 lb)	25000 kg (55115.6 lb)
Max. eccentric loading	500 kg (1102.3 lb)	1000 kg (2204.6 lb)	2500 kg (5511.6 lb)	5000 kg (11023.1 lb)	7500 kg (16534.7 lb)	10000 kg (22046.2 lb)	12500 kg (27557.8 lb)
Dimensions							
A	920 mm (36.2 in)	1220 mm (48 in)	1830 mm (72 in)	1830 mm (72 in)	2350 mm (92.5 in)		
B	500 mm (19.7 in)	500 mm (19.7 in)	585 mm (23 in)	585 mm (23 in)	585 mm (23 in)		
C	1500 mm (59.1 in)	1500 mm (59.1 in)	1700 mm (66.9 in)	1625 mm (64 in)	2000 mm (78.7 in)		
D	1350 mm (53.1 in)	1350 mm (53.1 in)	1700 mm (66.9 in)	1500 mm (59.1 in)	2000 mm (78.7 in)		
E	1125 mm (44.3 in)	1125 mm (44.3 in)	1271 mm (50 in)	1125 mm (44.3 in)	1450 mm (57.1 in)		
F	926 mm (36.5 in)	926 mm (36.5 in)	1121 mm (44.1 in)	1026 mm (40.4 in)	1250 mm (49.2 in)		
G	100 mm (3.9 in)	100 mm (3.9 in)	70 mm (2.8 in)	100 mm (3.9 in)	50 mm (2 in)		
Number/size of fastening holes	4/23 mm (0.91 in)	4/23 mm (0.91 in)	4/24 mm (0.91 in)	4/24 mm (0.91 in)	4/24 mm (0.91 in)	4/24 mm (0.91 in)	4/24 mm (0.91 in)
Max. welding-current transfer	600 A	600 A	600 A	600 A	600 A	600 A	600 A
Face-plate thickness	20 mm (0.8 in)	25 mm (1 in)	25 mm (1 in)	35 mm (1.4 in)	35 mm (1.4 in)	35 mm (1.4 in)	35 mm (1.4 in)
Max. table backlash	2 mm (0.08 in)	2 mm (0.08 in)	2 mm (0.08 in)	2 mm (0.08 in)	2 mm (0.08 in)	2 mm (0.08 in)	2 mm (0.08 in)
Number of slots	8	8	8	8	8	8	8
Slots suitable for bolt size	M20	M20	M20	M20	M20	M20	M20
Rotation speed	0,07-3,0 rpm	0,07-3,0 rpm	0,07-3,0 rpm	0,07-3,0 rpm	0,07-3,0 rpm	0,07-3,0 rpm	0,07-3,0 rpm
Mains voltage, 50 Hz	3 x 400 V	3 x 400 V	3 x 400 V	3 x 400 V	3 x 400 V	3 x 400 V	3 x 400 V
Mains cable	10 m (393.7 in)	10 m (393.7 in)	10 m (393.7 in)	10 m (393.7 in)	10 m (393.7 in)	10 m (393.7 in)	10 m (393.7 in)
Net weight	900 kg (1984.2 lb)	1050 kg (2314.9 lb)	1900 kg (4188.8 lb)	1750 kg (3858.1 lb)	3300 kg (7275.3 lb)	3400 kg (7495.7 lb)	3700 kg (8157.1 lb)

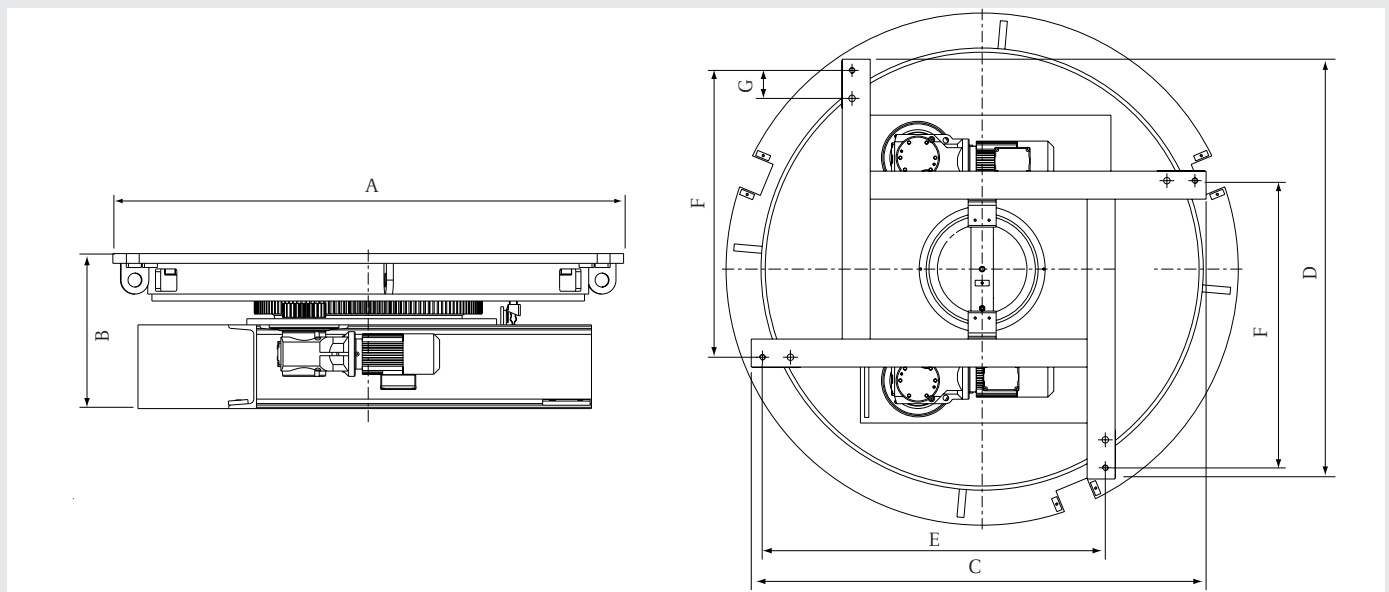

/ Battery Charging Systems / Welding Technology / Solar Electronics

WE HAVE THREE DIVISIONS AND ONE PASSION: SHIFTING THE LIMITS.

/ Whether Battery Charging Systems, Welding Technology or Solar Electronics - our goal is clearly defined: to be the technology and quality leader. With around 3,000 employees worldwide, we shift the limits of what's possible - our more than 850 active patents are testimony to this. While others progress step by step, we innovate in leaps and bounds. Further information about all Fronius products and our global sales partners and representatives can be found at www.fronius.com



Fronius Canada Ltd.
2875 Argentia Road, Units 4,5 & 6
Mississauga, ON L5N 8G6
Canada
Telephone +1 905 288-2100
Fax +1 905 288-2101
sales.canada@fronius.com
www.fronius.ca

Fronius USA LLC
6797 Fronius Drive
Portage, IN 46368
USA
Telephone +1 877 FRONIUS
sales.usa@fronius.com
www.fronius-usa.com

Fronius UK Limited
Maidstone Road, Kingston
Milton Keynes, MK10 0BD
United Kingdom
Telephone +44 1908 512 300
Fax +44 1908 512 329
sales.uk@fronius.com
www.fronius.co.uk

Fronius International GmbH
Froniusplatz 1
4600 Wels
Austria
Telephone +43 7242 241-0
Fax +43 7242 241-953940
sales@fronius.com
www.fronius.com

v02 2012 EN