

ROTATION TABLES FRT 50-150 HS125/H/V

/ Max. load capacity from 50-150 kg
(110.2 - 330.7 lb)

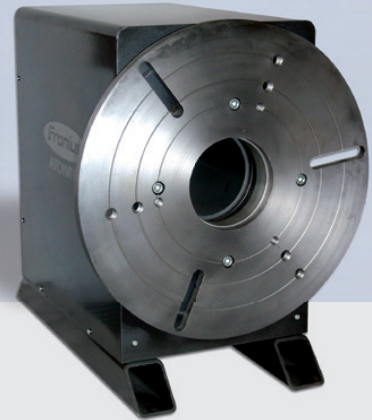

/ Horizontal rotation tables are universal applicable for mechanized welding applications as well as for precise positioning of work pieces.

STANDARD EQUIPMENT

- / Constant speed control
- / AC-motor
- / Welding-current transfer 400 A/50 mm² (2 in²)
- / Prepared for segment welding
- / Hollow shaft 125 mm (4.9 in)
- / Limit switch function (360°)
- / Face plate with concentric circular markings
- / Protection housing (rotation device)

ACCESSORIES

- / Control unit FCU-10/FCU-20/FCU-50
- / Foot switch FRC-1 (start/stop) with cable 3 m (118 in)
- / Foot switch FRC-2 (start/stop/speed) with cable 3 m (118 in)
- / Foot switch FRC-3 (start/stop/direction) with cable 3 m (118 in)
- / Chucks FGC, FSG
- / Mounting sets for chucks
- / I-kit welding-current transfer +400 A
- / Actuating cam for segment welding
- / Stands

TECHNICAL DATA

	FRT 50/HS125/H/V	FRT 150/HS125/H/V
Max. load capacity	50 kg (110.2 lb)	150 kg (330.7 lb)
Slots	3 x 120°	3 x 120°
Faceplate slots and holes	DIN 6350	DIN 6350
Drive	AC-motor	AC-motor
Speed range	0,9-7,0 rpm	0,3-6,0 rpm
Dimensions		
A	340 mm (13.4 in)	542 mm (21.3 in)
B	540 mm (21.3 in)	710 mm (28 in)
C	590 mm (23.2 in)	490 mm (19.3 in)
D	571 mm (22.5 in)	481 mm (18.9 in)
E	315 mm (12.4 in)	432 mm (17 in)
F	450 mm (17.7 in)	450 mm (17.7 in)
G	125 mm (4.9 in)	125 mm (4.9 in)
Max. backlash on faceplate	1,2°	0,25°
Max. current transfer	400 A	400 A
Mains voltage, 50 - 60 Hz	230 V	230 V
Net weight	90 kg (198.4 lb)	145 kg (319.7 lb)

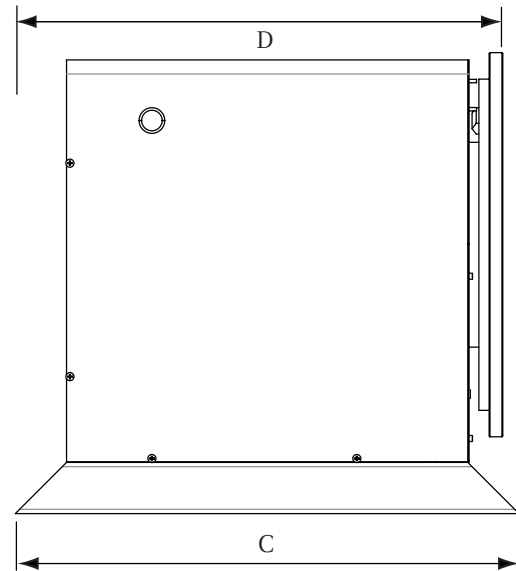
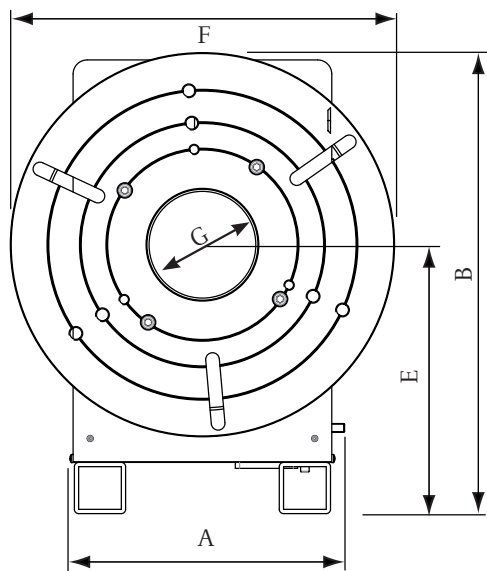

/ Battery Charging Systems / Welding Technology / Solar Electronics

WE HAVE THREE DIVISIONS AND ONE PASSION: SHIFTING THE LIMITS.

/ Whether Battery Charging Systems, Welding Technology or Solar Electronics - our goal is clearly defined: to be the technology and quality leader. With around 3,000 employees worldwide, we shift the limits of what's possible - our more than 850 active patents are testimony to this. While others progress step by step, we innovate in leaps and bounds. Further information about all Fronius products and our global sales partners and representatives can be found at www.fronius.com



Fronius Canada Ltd.
2875 Argentia Road, Units 4,5 & 6
Mississauga, ON L5N 8G6
Canada
Telephone +1 905 288-2100
Fax +1 905 288-2101
sales.canada@fronius.com
www.fronius.ca

Fronius USA LLC
6797 Fronius Drive
Portage, IN 46368
USA
Telephone +1 877 FRONIUS
sales.usa@fronius.com
www.fronius-usa.com

Fronius UK Limited
Maidstone Road, Kingston
Milton Keynes, MK10 0BD
United Kingdom
Telephone +44 1908 512 300
Fax +44 1908 512 329
sales.uk@fronius.com
www.fronius.co.uk

Fronius International GmbH
Froniusplatz 1
4600 Wels
Austria
Telephone +43 7242 241-0
Fax +43 7242 241-953940
sales@fronius.com
www.fronius.com

v02 2012 EN