

8A SUPER FAST RECOVERY RECTIFIER 50V-600V

Dim.	Value Inch[mm]	
	Min.	Max.
A	0.139 [3.55]	---
B	0.387 [9.85]	0.419 [10.66]
C	0.226 [5.75]	0.269 [6.85]
D	0.548 [13.93]	0.624 [15.87]
E	0.50 [12.70]	---
F	---	0.177 [4.50]
G	0.195[4.95]	0.204[5.18]
H	0.019 [0.50]	0.038 [0.96]
J	0.163 [4.16]	0.196 [5.00]
K	0.045 [1.15]	0.054 [1.39]
L	---	0.025 [0.65]

PRODUCT FEATURES

1. FLAMMABILITY CLASSIFICATION: 94V-0
2. GLASS PASSIVATED CHIP JUNCTION
3. LOW FORWARD VOLTAGE DROP
4. HIGH SURGE CURRENT CAPABILITY
5. LOW LOSSES
6. CASE: MOLDED PLASTIC, TO-220AC
7. POLARITY: AS MARKED
8. WEIGHT: 2.05 GRAMS
9. LEADS: SOLDERABILITY PER MIL-STD-202 METHOD 208
10. RoHS, SUFFIX "-H" INDICATES HALOGEN FREE PARTS

MAXIMUM RATINGS AND ELECTRICAL CHARACTERISTICS RATINGS AT 25°C AMBIENT TEMPERATURE UNLESS OTHERWISE SPECIFIED STORAGE AND OPERATING TEMPERATURE RANGE -55°C TO +150°C. SINGLE PHASE, HALF WAVE, 60 HZ, RESISTIVE OR INDUCTIVE LOAD. FOR CAPACITIVE LOAD, DERATE CURRENT BY 20%.

RATINGS	SYMBOL	VALUE	UNITS
MAXIMUM AVERAGE FORWARD RECTIFIED CURRENT	I_O	8	A
PEAK FWD SURGE CURRENT, 8.3ms HALF SINE-WAVE SUPERIMPOSED ON RATED LOAD	I_{FSM}	125	A
TYPICAL THERMAL RESISTANCE (NOTE 1)	$R_{\theta jc}$	2	°C/W
MAXIMUM REVERSE CURRENT @ 25°C	I_R	5	uA
MAXIMUM REVERSE CURRENT @ 125°C	I_R	400	uA
MAXIMUM REVERSE RECOVERY TIME	T_{RR}	35	nS

1. THERMAL RESISTANCE JUNCTION TO CASE PER LEG MOUNTED ON HEAT SINK
2. REVERSE RECOVERY TEST CONDITIONS: $I_F=0.5A$, $I_R=1.0A$, $I_{RR}=0.25A$
3. MAXIMUM FORWARD VOLTAGE @ I_O DC

PART NUMBER	MAX RECURRENT PK REV VOLTAGE V_{RRM} (V)	MAX RMS VOLTAGE V_{RMS} (V)	MAX DC BLOCKING VOLTAGE V_{DC} (V)	MAX FWD VOLTAGE V_F (V)	MARKING
SF8A05	50	35	50	0.98	SF8A05
SF8A10	100	70	100	0.98	SF8A10
SF8A20	200	140	200	0.98	SF8A20
SF8A40	400	280	400	1.3	SF8A40
SF8A60	600	420	600	1.85	SF8A60

RATING AND CHARACTERISTIC CURVES

FIG.1-TYPICAL FORWARD CURRENT DERATING CURVE

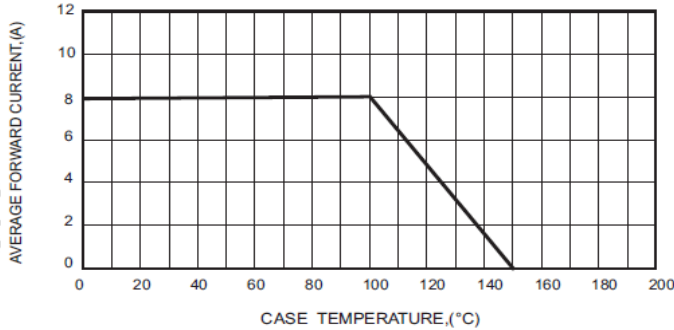

FIG.3-MAXIMUM NON-REPETITIVE FORWARD SURGE CURRENT

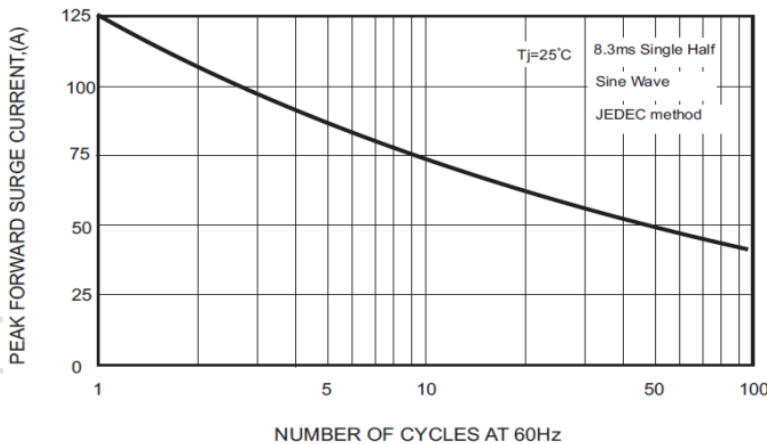
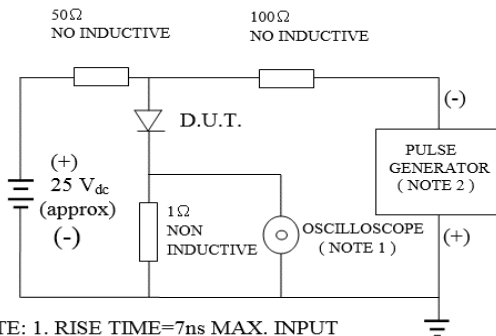

FIG. 1-TEST CIRCUIT DIAGRAM AND REVERSE RECOVERY TIME CHARACTERISTIC



NOTE: 1. RISE TIME=7ns MAX. INPUT IMPEDANCE=1 MOhms 22PF
 2. RISE TIME =10ns MAX. SOURCE IMPEDANCE=50 OHMS

FIG.2-TYPICAL FORWARD CHARACTERISTICS

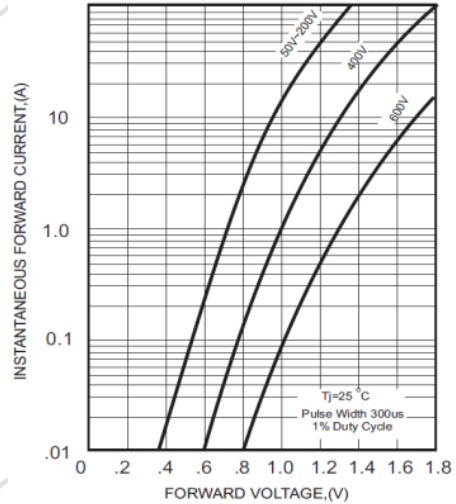

FIG.4 - TYPICAL REVERSE CHARACTERISTICS

