

NOSE ASSEMBLY DATA SHEET

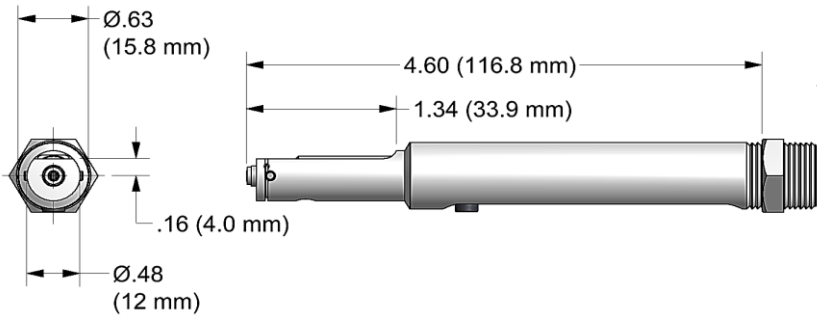

**POINT NOSE ASSEMBLY DOWN
WHEN ATTACHING TO TOOL**



Effective FOD Control (foreign object damage/debris). Install catcher bag on the front of the riveter to catch spent pintail stems. Place nose assembly through grommet on catcher bag and easily fasten catcher bag to tool using the Velcro strap. Features an easily emptied zippered pouch.

Use catcher bag 500610 for XX-51-46 straight nose assemblies

Catcher bag sold separately

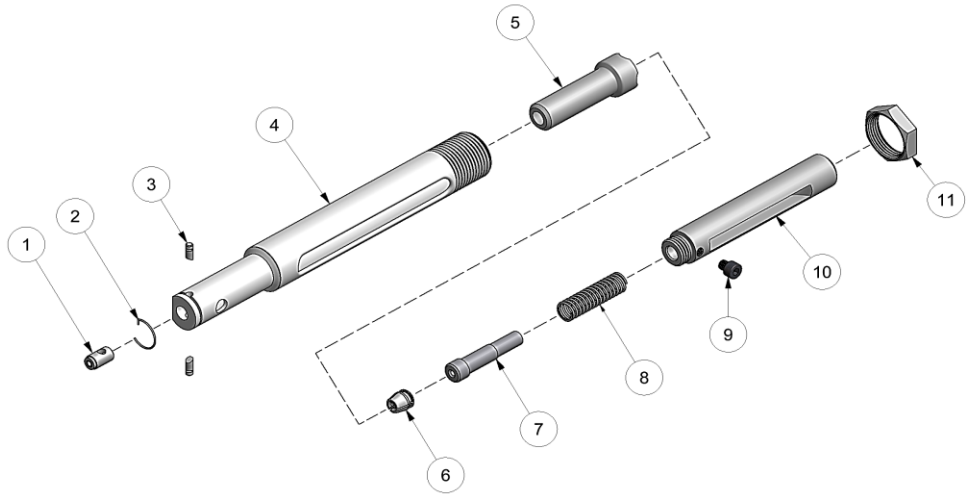

1/99 Rev. 5/16

GAGE BILT
MADE in the USA

GAGE BILT Inc.

44766 Centre Court +1 (586) 226-1500
Clinton Twp. MI 48038 USA +1 (586) 226-1505 Fax
e-mail: solutions@gagebilt.com / www.gagebilt.com

Type:
Single Action
Non Self-Releasing

Fasteners:
NAS1398A/1399A
NAS1738A/1739A
RV1000/1100 & 12000

Recommended Tool:
GB50

5/32" Ø

Alternate Tools:
GB51 & GB715

Ref. No.	Qty.	Description	5A-51-46
1	1	Anvil Insert	13434
2	1	Retaining Ring	50308
3	2	Ratchet Pin	15586
4	1	Anvil Holder	10318
5	1	Collet	20326
6	1	Chuck Jaws (Inc. 50318)	30547
7	1	Follower	40304
8	1	Spring	50307
9	1	Socket Head Cap Screw	70303
10	1	Drawbolt	70301
11	1	Jam Nut	70411