

751206-5 ADAPTER DATA SHEET

To attach adapter and nose to tool:

1. Remove nose assembly drawbar from nose assembly.
2. Thread collet adapter (2) onto head piston.
3. With collet placed in nose assembly anvil, tighten both onto anvil adapter assembly (1).
4. Slide anvil adapter (1) over collet adapter (2) and lock into place on tool.
5. Slide drawbar into nose assembly and screw into collet adapter.

CAUTION

Pintail may eject forcibly.
To prevent severe personal injury, use for closed access applications only!

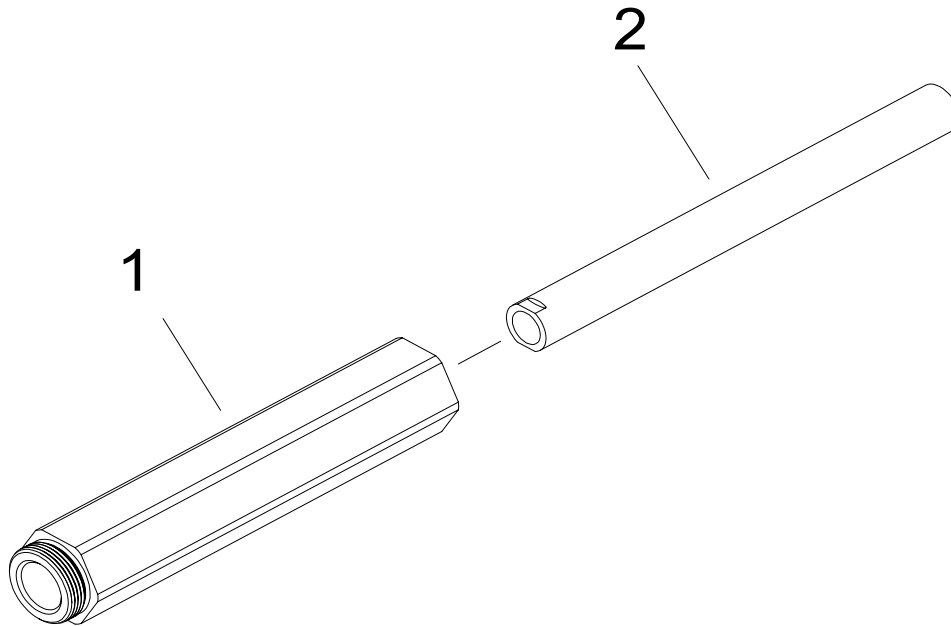

7/04

GAGE BILT

GAGE BILT Inc.

44766 Centre Court (586) 226-1500
 Clinton Twp., MI 48038 (586) 226-1505 Fax
 e-mail:solutions@gagebilt.com / www.gagebilt.com

Type:		Adapts GB206 Series and HUCK® 99-1700 & 99-3700 (206-375) Series Nose Assemblies to:	
Offset Nose Assembly Adapter		GB731, GB751 and GB722 Installation Tools	
Ref. No.	Qty.	Description	751206-5
1	1	Anvil Adapter Assembly	751210
2	1	Collet Adapter	352214