

GAGE BILT

GB704RK & GB704RK-1 Blind Rivet Kits

GAGE BILT offers a complete tool kit for installing HUCK® and CHERRY® blind rivets per NAS9301-NAS9312, M7885, BACR15FP/FR and BACR15GF/GK.

The basic kit, GB704RK, contains a straight nose to install -4 (1/8”), -5 (5/32”) and -6 (3/16”) diameter blind rivets, bleeder bottle, pintail catcher bag and a grip selector gage.

The GB704RK-1 kit also contains a right angle and an offset nose, must items for re-work operations.

All these items are stored in an easy access carrying case with a manual, data sheets, **POWERMAX** tools manual and pocket card.





GB704RK		
QTY	ITEM	DESCRIPTION
1	GB704	INSTALL TOOL
1	456MAX-701-17	NOSE ASSY
1	704153	AIR BLEEDER ASSY
1	269G3S	SELECTION GAGE ASSY
1	704214	CATCHER BAG-STEM
1	704221	METAL CARRYING CASE
1	A-140	POCKET CARD
1	PROCESS MANUAL	POWERMAX

GB704RK-1		
QTY	ITEM	DESCRIPTION
1	GB704	INSTALL TOOL
1	456MAX-701-17	NOSE ASSY
1	456MAX-704-54RA	NOSE ASSY RT ANGLE
1	456MAX-704-43OS	NOSE ASSY OFFSET
1	704153	AIR BLEEDER ASSY
1	269G3S	SELECTION GAGE ASSY
1	704214	CATCHER BAG-STEM
1	704221	CARRYING CASE ASSY
1	A-140	POCKET CARD
1	PROCESS MANUAL	POWERMAX

Equivalent to G704BCMR

GAGE BILT
MADE in USA

44766 Centre Court Clinton Twp. MI 48038 USA
Ph: +1 (586) 226-1500 Fax: +1 (586) 226-1505
solutions@gagebilt.com / www.gagebilt.com

CHERRYMAX®, ALLMAX®, HUCKMAX® NAS9301-9312, M7885 BACR15FP/FR & BACR15GF/GK	DIA.	NOSE ASSEMBLIES		
		STRAIGHT	RIGHT ANGLE	OFFSET
	1/8"	456MAX-701-17 (PULLS ALL 3)	456MAX-704-54RA (PULLS ALL 3)	456MAX-704-43OS (PULLS ALL 3)
	5/32"			
	3/16"			

CHERRY® AND CHERRYMAX® ARE REGISTERED TRADEMARKS OF CHERRY AEROSPACE FASTENER. ALLMAX® IS A REGISTERED TRADEMARK OF ALLFAST FASTENING SYSTEMS, INC. HUCK® AND HUCKMAX® ARE REGISTERED TRADEMARKS OF ALCOA INC.

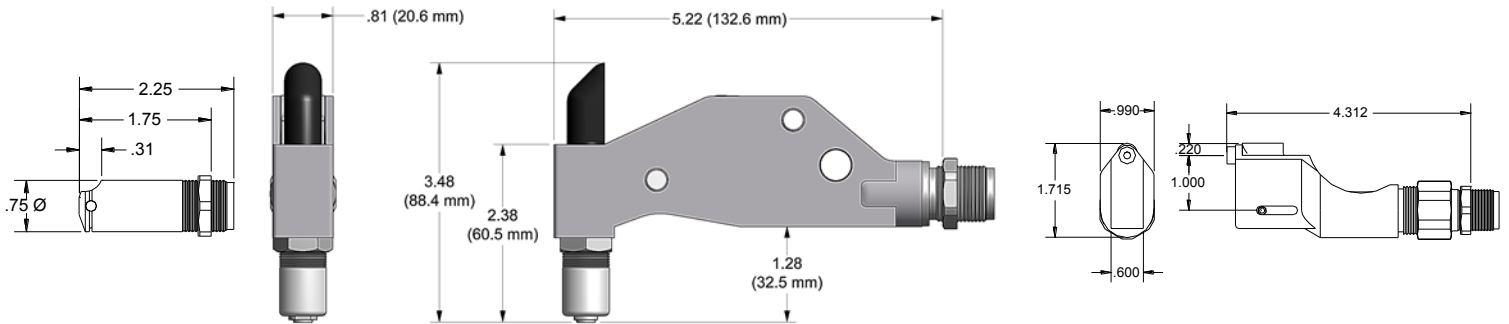

STRAIGHT

RIGHT ANGLE

OFFSET

