

NOSE ASSEMBLY DATA SHEET

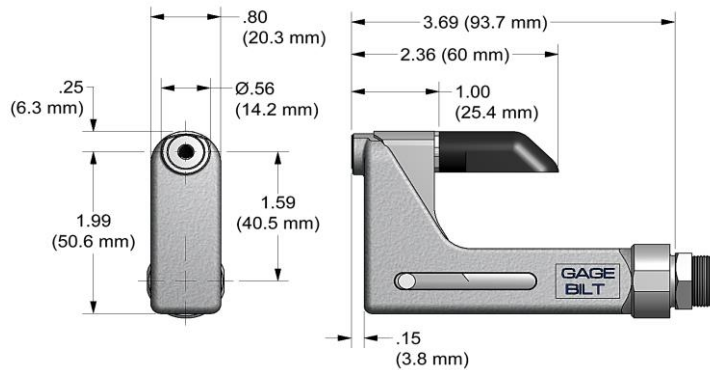

CAUTION!

Do not operate if pintail deflector is removed. Pintail may eject forcibly. SEVERE PERSONAL INJURY MAY RESULT.

Attachment

Screw nose assembly onto tool until it stops then back off until nose is in desired position. (Warning: do not back off nose assembly more than one complete turn). Lock jam nut (70411) against adapter (70341)

WARNING:
KEEP FINGERS AND HANDS AWAY FROM NOSE ASSEMBLY DURING OPERATION TO PREVENT SEVERE PERSONAL INJURY.

*GB715 & GB51 for aluminum fasteners only.

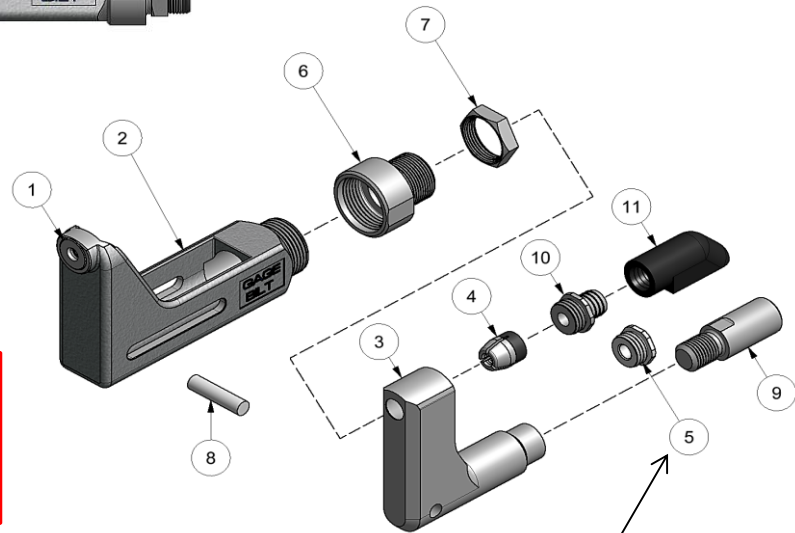

Cap (5) is used for closed access applications only or when clearance is an issue.

4/15

GAGE BILT

GAGE BILT Inc.

44766 Centre Court (586) 226-1500
Clinton Twp. MI 48038 (586) 226-1505 Fax
e-mail:solutions@gagebilt.com / www.gagebilt.com

Type:		Fasteners:	Recommended Tool:
Non Self-Releasing 1/4" Ø		MS20600, Cherry® 9000 Huck® PT, SP & MS RV200 & RV500	*GB715
			Alternate Tools: *GB51
Ref. No.	Qty.	Description	*8C-715-400S
1	1	Anvil Insert	18012
2	1	Anvil & Holder Assy (Inc. #1)	12342
3	1	Collet	20911
4	1	Super-Grip Jaw Assy	30864-S5
5	1	Cap	60428
6	1	Anvil Adapter	70341
7	1	Jam Nut	70411
8	1	Pin	70468
9	1	Collet Adapter	70340
10	1	Barbed Retainer	60440
11	1	Deflector	61107