

NOSE ASSEMBLY DATA SHEET

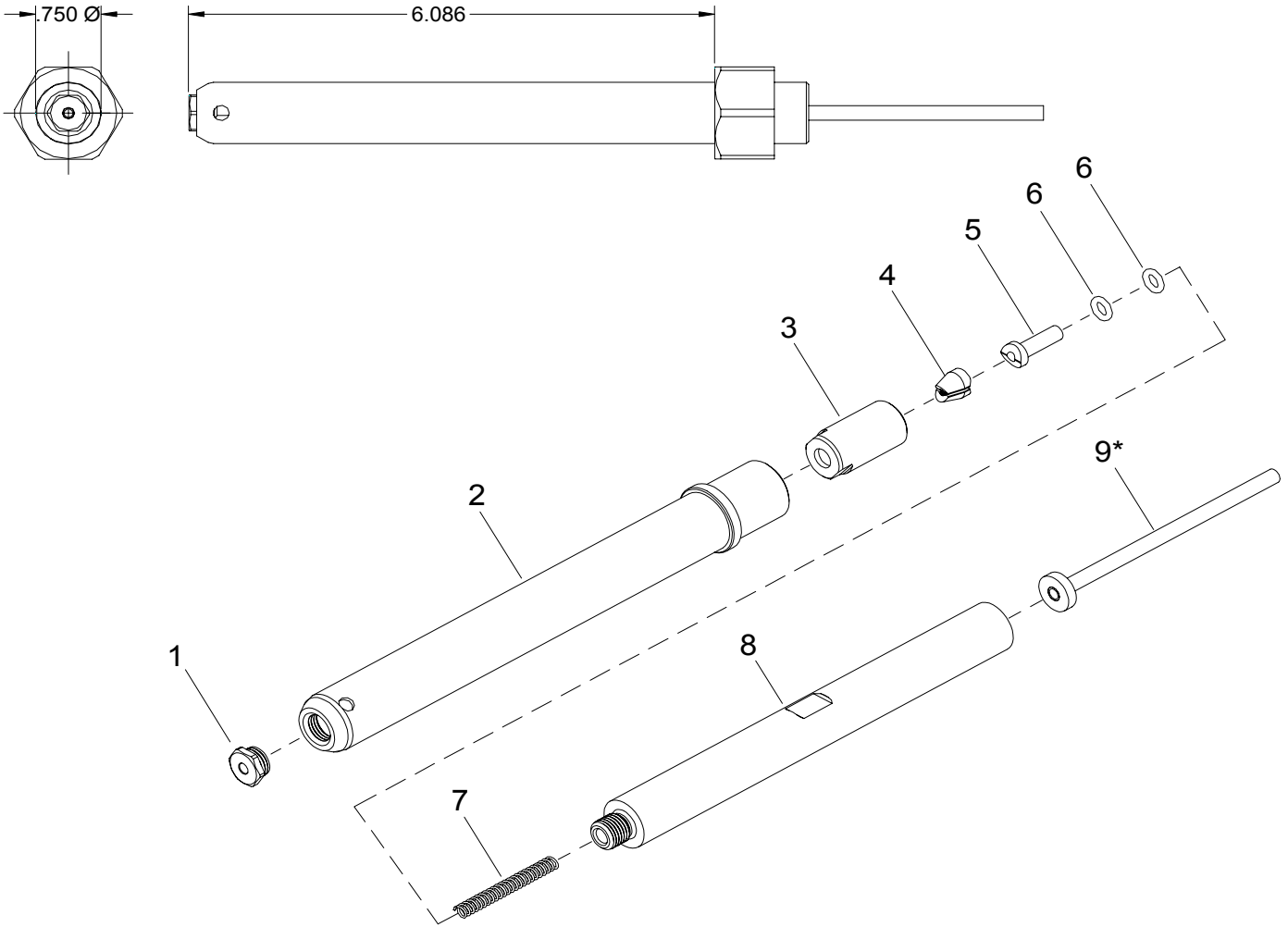

Use Hex-Key in rear of piston for nose assembly attachment.

*Remove for -6 Intermax and NAS1919/21 U.

11/06 REV. 3/12

GAGE BILT
MADE IN U.S.A.

GAGE BILT Inc.

44766 Centre Court (586) 226-1500
Clinton Twp. MI 48038 (586) 226-1505 Fax
e-mail:solutions@gagebilt.com / www.gagebilt.com

Type:		Fastener:		Recommended Tool:	
Non Self-Releasing 1/8", 5/32" & 3/16" Ø		CHERRYMAX®, CHERRYMAX® 'AB', MBC® LOCK CREATOR BACR15FR/FP, BACR15GF/GK,		GB752	
				Alternate Tools: GB751 & GB2480(A)	
Ref. No.	Qty.	Description		456MAX-751A-61	
1	1	Nose Tip		10206-1	
2	1	Anvil-Holder		10942-5	
3	1	Collet		70105	
4	1	Jaw Set		30513	
5	1	Follower		40506	
6	2	O'Ring		400774	
7	1	Spring		70109	
8	1	Collet Extension		70467	
9*	1	Pintail Tube		40446	