

NOSE ASSEMBLY DATA SHEET

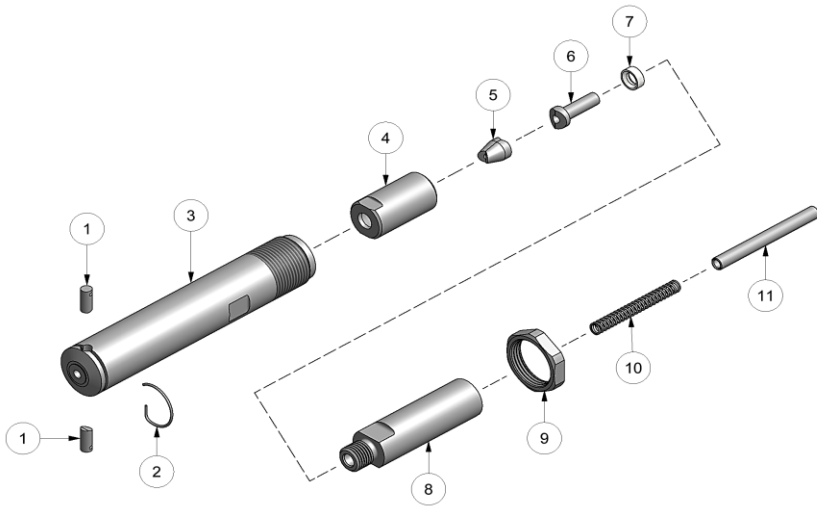
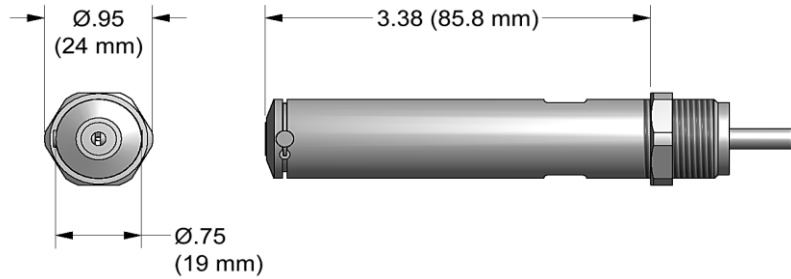

4/12 Rev. 8/16

ASSEMBLY:

Note: If nose assy is assembled as it is when purchased new, follow steps 1 & 5 to attach to tool.

1. Slide tube (11) into piston of tool. Screw collet bolt (8) onto end of piston. Secure using wrench on flat provided.
2. Place jaw set (5) inside collet (4).
3. Place bumper (7) over follower (6) and place this assy in collet (4) against jaw set (5) making sure tapered end on follower (6) lines up with the split line of jaw set (5).
4. Slide spring (10) into front of collet bolt (8). Screw collet assembly onto the end of collet bolt (8). Tighten securely using wrenches on flats provided.
5. Take anvil (3) with jam nut (9) assembled and slide over the collet assy. Thread into end of head cylinder until snug. Tighten jam nut securely.

DISASSEMBLY:

Reverse assembly instructions.

GAGE BILT
MADE in USA

44766 Centre Court Clinton Twp. MI 48038 USA
Ph: +1 (586) 226-1500 Fax: +1 (586) 226-1505
solutions@gagebilt.com / www.gagebilt.com

Type:		Fasteners:		Recommended Tool: GB704
Non Self-Releasing 1/8", 5/32" & 3/16" Ø		CHERRYMAX®, CHERRYMAX® 'AB', MBC® LOCK CREATOR BACR15FR/FP, BACR15GF/GK, NAS1900 S & U SERIES BLIND RIVET WITH DRIVE WASHER		
Ref. No.	Qty.	Description	456MAX-704-35	
1	1	Stem Stop	70102	
2	1	Retaining Ring	70101	
3	1	Anvil	13460	
4	1	Collet	70105	
5	1	Jaw Set	30513	
6	1	Follower	40506	
7	1	Bumper	70108	
8	1	Collet Bolt	70413-1	
9	1	Jam Nut	70104	
10	1	Spring	70109	
11	1	Tube	70471	