

NOSE ASSEMBLY DATA SHEET

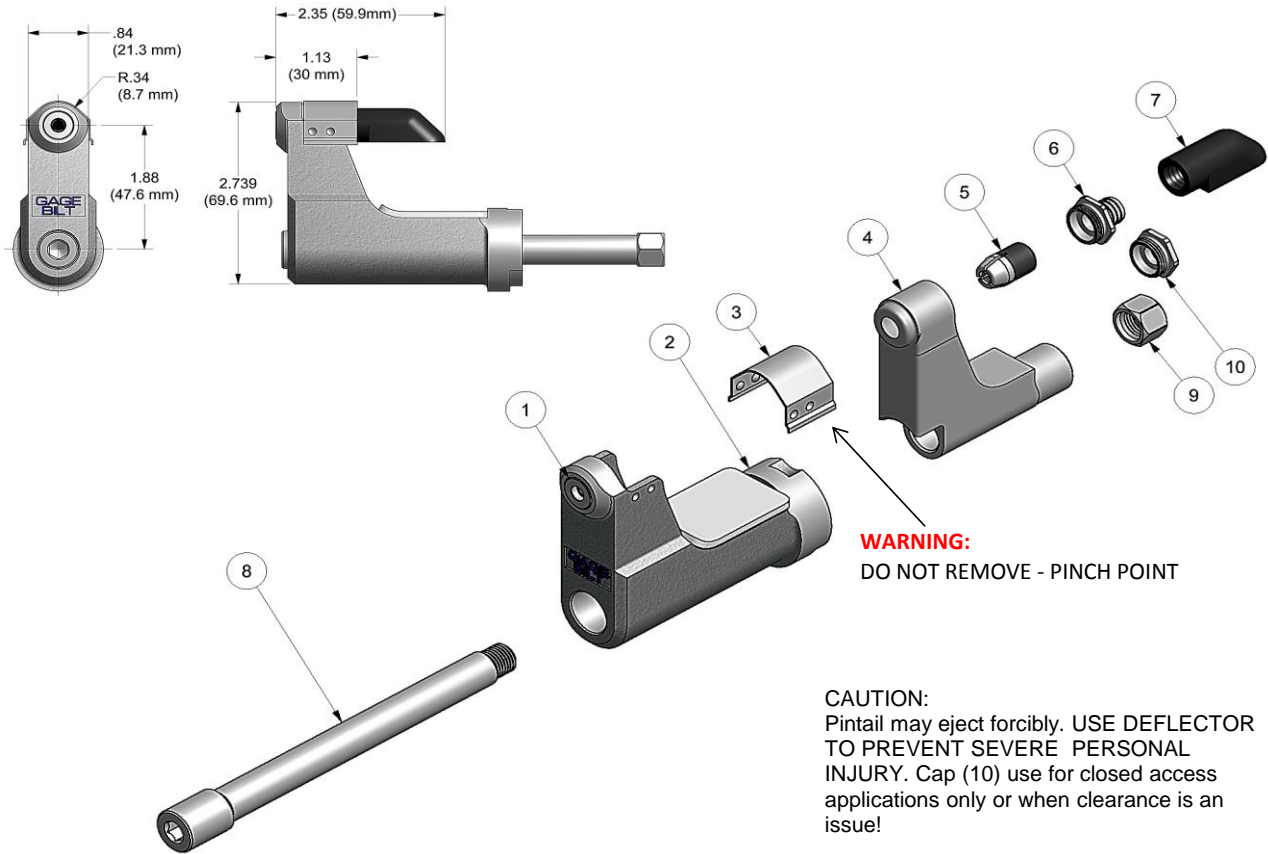

ASSEMBLY INSTRUCTIONS:

On front of GB204 installation tool remove screw and stop. With collet placed in housing, install on tool. Slide draw bar thru housing and collet. Using an allen wrench, Tighten the nut on the end of the draw bar (apply Vibra-TITE® part no. 405124 to threads on draw bar). Replace screw and stop on tool.



1/11 REV 3/15

Covered Under Patent No. 5,371,933

*Use Adapter No. 751204.

**Use Adapter No. 353204.

GAGE BILT
MADE in the USA

GAGE BILT Inc.
44766 Centre Court +1 (586) 226-1500
Clinton Twp. MI 48038 USA +1 (586) 226-1505 Fax
e-mail: solutions@gagebilt.com / www.gagebilt.com

Type:		Fastener:	Recommended Tool GB204 & GB204(A)
Non Self-Releasing 1/4" Ø		CHERRYMAX® BACR15FR & FP M7885 / NAS9300	Alternate Tools: *GB752, **GB745 & *GB722
Ref. No.	Qty.	Description	08MAX-204D-370S
1	1	Anvil-Driving	18009
2	1	Anvil & Holder Assy (Inc. #1)	10998
3	1	Guard	60426
4	1	Collet	20723
5	1	Super-Grip Jaw Assy	30864-S13
6	1	Barbed Retainer	70569
7	1	Deflector	61107
8	1	Draw Bar	71117
9	1	Nut	71114
10	1	Cap	70571