

# GB7310S

## INSTALLATION TOOL

S/N: 1119 AND ABOVE  
PLEASE CONTACT GAGE BILT FOR  
ALL OTHER SERIAL NUMBERS.

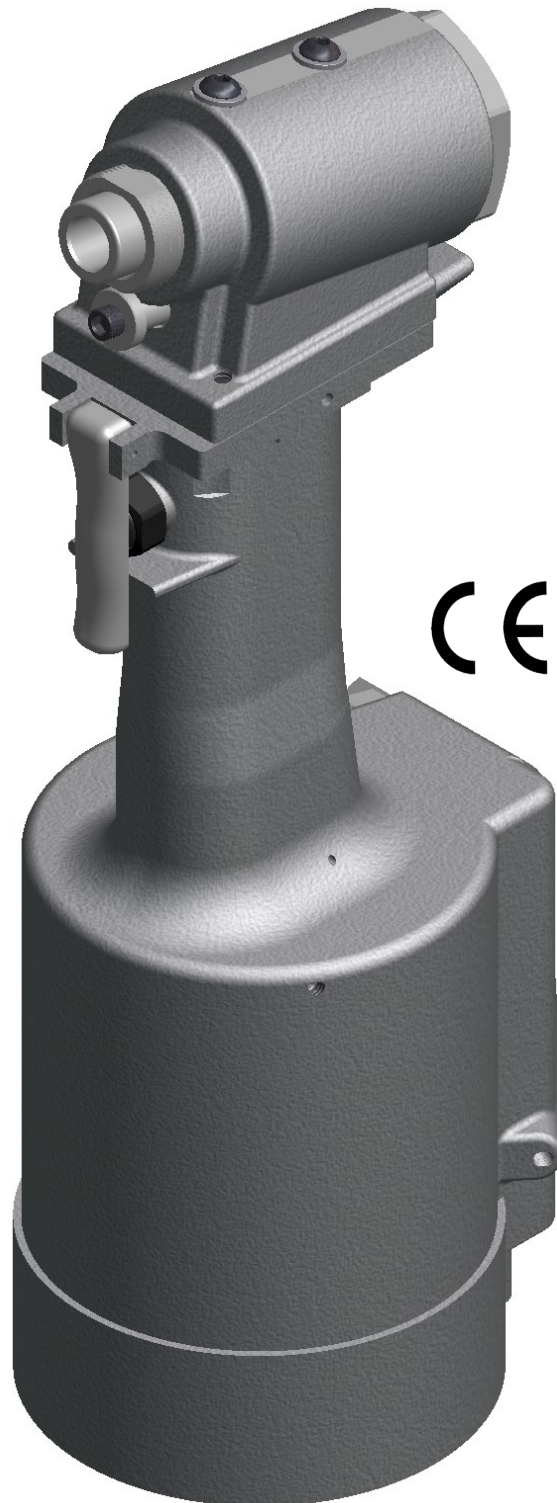

GAGE BILT TOOLS ARE AVAILABLE WORLDWIDE  
E-MAIL US FOR A DISTRIBUTOR NEAR YOU.

**GAGE BILT**  
MADE IN U.S.A.

**GAGE BILT Inc.**  
44766 Centre Court (586) 226-1500  
Clinton Twp. MI 48038 (586) 226-1505 Fax  
e-mail: [solutions@gagebilt.com](mailto:solutions@gagebilt.com) / [www.gagebilt.com](http://www.gagebilt.com)

## TABLE OF CONTENTS

<u>Description</u>	<u>Page</u>
Warnings.....	3
Principle of Operation.....	4
How to use the GB731OS .....	5
Description and Maintenance.....	6
Filling and Bleeding .....	7
Troubleshooting.....	8
Overhaul.....	9
Parts List.....	10-11
DEXRON® III Oil Safety Data .....	12
Nose Assembly Selection Chart .....	13
EU Conformity and Warranty .....	14

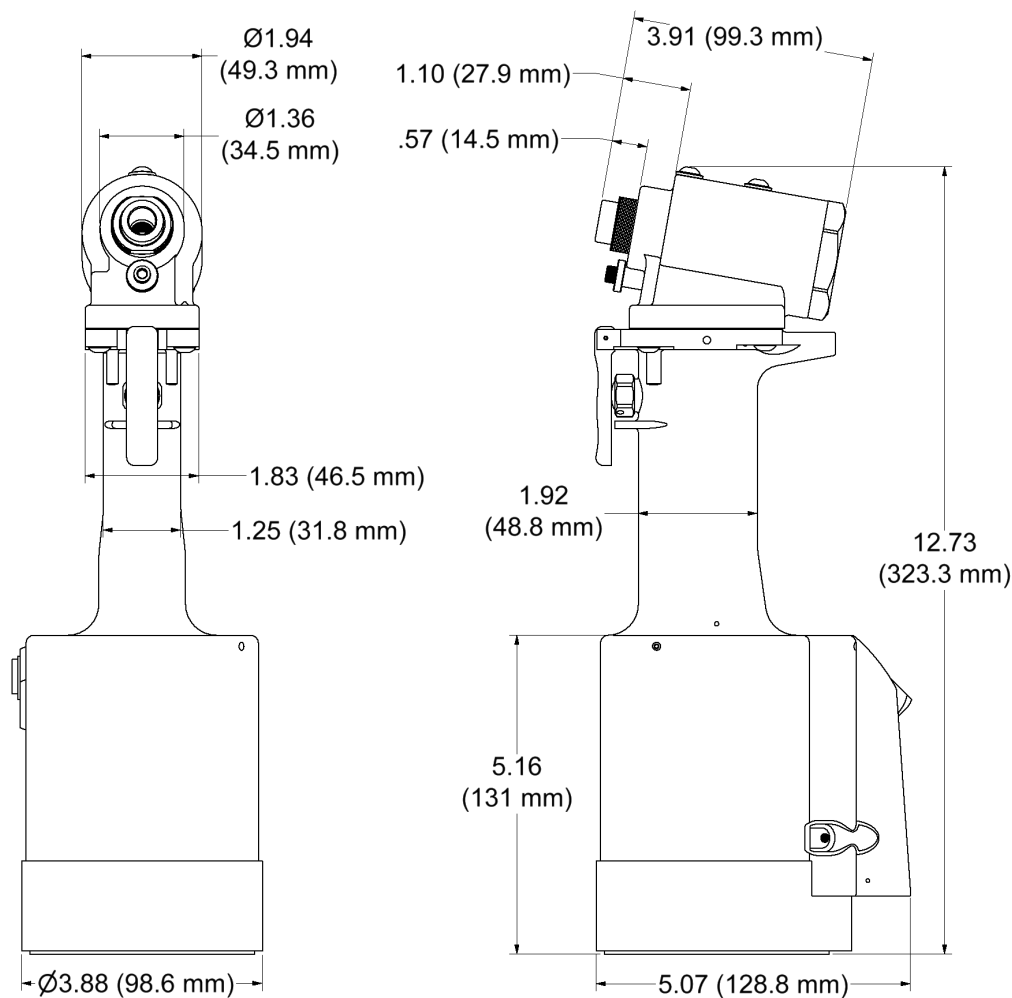

## SPECIFICATIONS

<b>Hand Held Weight</b>	- 5.75 lbs. (2.6 kg)
<b>Air pressure req'd</b>	- 90-100 p.s.i. (6.2-6.9 bar)
<b>Air consumption</b>	- .16 SCF/cycle (4.53 L/cycle)
<b>Hydraulic oil</b>	- Automatic Transmission Oil, Dexron III, or equivalent.
<b>Setting stroke</b>	- .600" (15.24 mm)
<b>Rated pull load</b>	- 4,800 lbs. (21.35 kN)
<b>Noise level</b>	- 81.5 dB (A)
<b>Vibration</b>	- Tested-No Hazards Found

# SAFETY WARNINGS



**PLEASE READ THIS MANUAL BEFORE  
SERVICING OR USING THIS TOOL.**



## **WARNINGS:**

**MUST BE UNDERSTOOD TO AVOID  
SEVERE PERSONAL INJURY**

## **CAUTIONS:**

**SHOW CONDITIONS THAT WILL  
DAMAGE EQUIPMENT OR STRUCTURE**

### **WARNING**

Do not pull fastener unless it is placed in an assembly, pin will eject forcibly when pintail breaks off. Severe personal injury may result.

### **WARNING**

Do not operate without Stat-O-Seal (S572) and cap screws (402482). Pressurized hydraulic oil may cause severe personal injury.

### **WARNING**

When operating, repairing or overhauling tool, wear approved eye protection. Do not look in front of nose assembly or rear of tool when installing fastener.

### **WARNING**

Always disconnect tool from power source before performing any maintenance to any tool or nose assembly.

### **WARNING**

Do not operate if deflector, bottle, catcher bag or vacuum tube is removed or damaged, broken pintails may eject forcibly from rear of tool. Severe personal injury may result.

### **WARNING**

Ensure that all connections are properly secured before connecting to power.

### **CAUTION**

Keep Nose Assemblies clean and free of chips and debris.

### **CAUTION**

Ensure that nose assembly and tip are properly matched for the fastener being installed.

### **CAUTION**

Do not use beyond the design intent.

### **WARNING**

Be sure there is adequate clearance for tool and operator's hands before proceeding. Keep fingers clear of any moving parts. Keep fingers clear from fasteners and installed materials. Severe personal injury may result.

### **WARNING**

Tool must be maintained in a safe working condition at all times and examined on a daily basis for damage or wear. Any repair should be done by qualified personnel trained on Gage Bilt procedures.

### **WARNING**

It is required to use hearing protection. A test was carried out in a simulated work environment where the background level was 73.2 dB (A). In this condition the max level was 81.5 dB (A). Therefore, it is required where prolonged use, hearing protection be used.

### **WARNING**

Where prolonged use is foreseen, it is recommended a tool balancer be used. Check suspension device to ensure that it is secure.

### **WARNING**

Risk of crushing exists if nose assembly is not attached.

### **WARNING**

Do no use tool in explosive atmosphere.

### **WARNING**

It is recommended tool be operated 50 out of every 60 minutes, where prolonged use is expected.

### **WARNING**

#### **Shock:**

It is recommended operator wear a suitable glove during operation where prolonged use is expected.

### **CAUTION**

Tool is not to be used as a hammer.

### **WARNING**

Air pressure not to exceed 100 psi (6.9 bar).

## PRINCIPLE OF OPERATION

When the actuator lever assy is depressed, the pressurized air inside of the tool is released allowing spring pressure to move the valve spool assy causing the air to be redirected. The air is directed to the top side of the air piston assy, moving it in a downward direction. The air below the air piston assy is then directed through the valve sleeve and exhausted out of the bottom of the tool. Simultaneously, the piston rod assy connected to the air piston assy is also moving down, forcing hydraulic oil up and into the front side of the head cylinder, causing the piston to move to the rear of the head cylinder. The oil from the rear of the head cylinder is directed to the top of the piston rod assy inside the power cylinder. The internal components of the attached nose assembly are also moving with the piston to start the fastener installation. When the fastener installation is completed, the actuator lever assy is released. Air pressure is then built up inside of the handle assy causing the valve spool assy to return to it's original position and reversing the sequence.

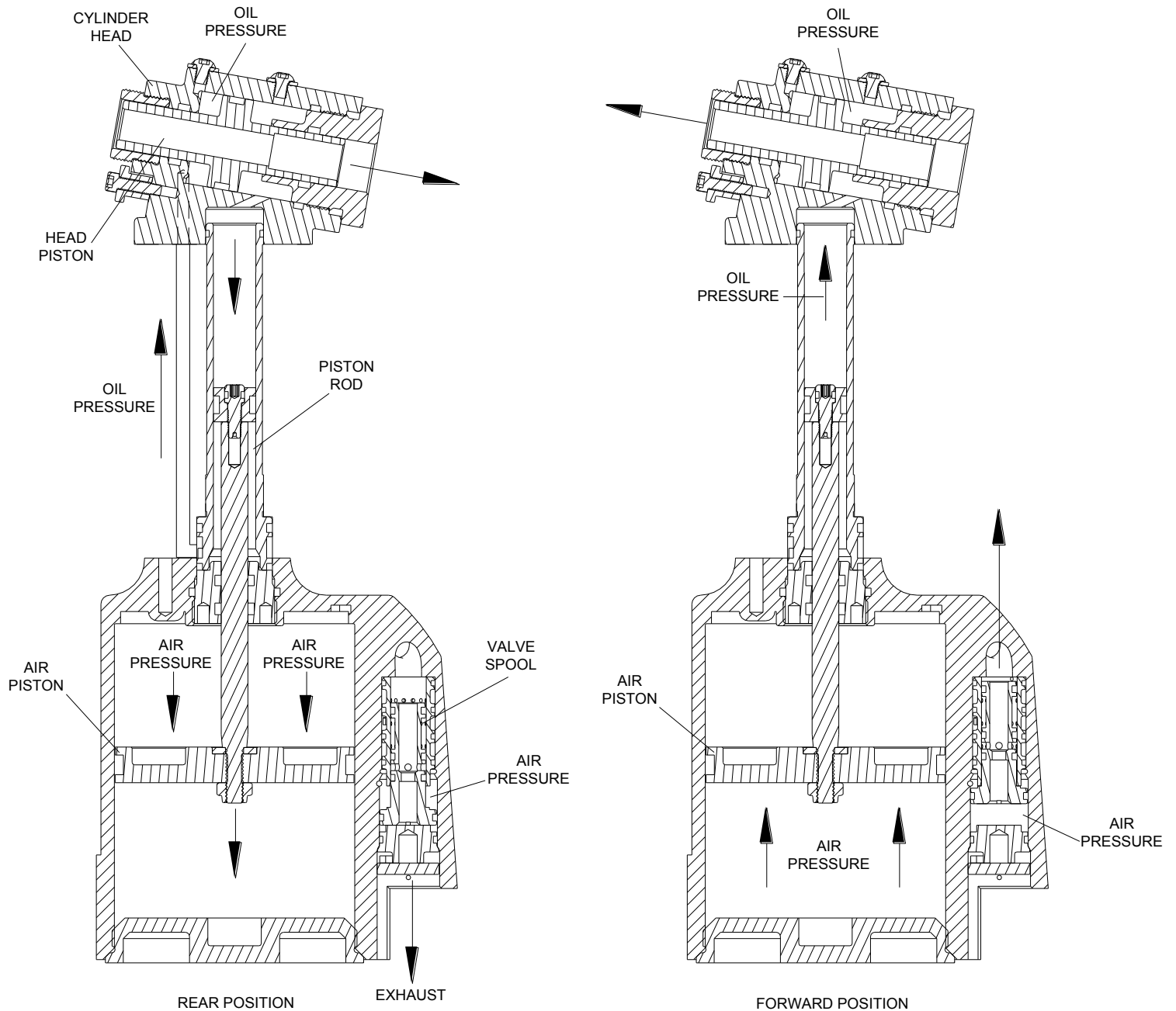

*Image may not reflect actual tool*

## HOW TO USE THE GB7310S

**WARNING:** Operator **MUST** read and understand all warnings and cautions.

**WARNING:** It is required that eye protection and hearing protection be worn during operation.

**WARNING:** Do not pull rivet in the air. Personal injury from fastener ejecting may occur.

**WARNING:** Air is exhausted from bottom of the tool. Direct bottom of the tool (exhausted air) away from operator, other persons working in the vicinity, foreign matter and liquid.

**CAUTION:** Do not use beyond design intent.

The tool is shipped with a plastic plug in the air inlet connector. The connector has a 1/4-18 female pipe thread to accept end-user air hose fitting. The tool comes with oil and is ready to use.

1. Remove plastic shipping plug from Swivel (A-249) and screw in your air fitting.

**WARNING:** Rotate deflector away from operator and other persons working in the vicinity.

2. Connect air hose to tool (3/8 minimum diameter air line is mandatory, 90 p.s.i. (6.2 bar) is recommended) and cycle tool ten times by depressing and releasing actuator lever assy (704343). (Clean dry air is recommended.)

**WARNING:** Ensure air hose is securely connected to avoid possible hose whipping.

3. Disconnect air hose from tool.

4. Select proper Nose Assembly, screw collet and anvil onto the tool and attach securely. (See proper data sheet for further instructions.)

5. Connect air supply.

6. Insert rivet into Nose Assembly and the application then depress actuator lever assy (704343). Upon releasing the actuator lever assy (704343) the stem will eject to the rear of the tool.

**WARNING:** Always disconnect air supply when tool is not in use to prevent accidental start-up.

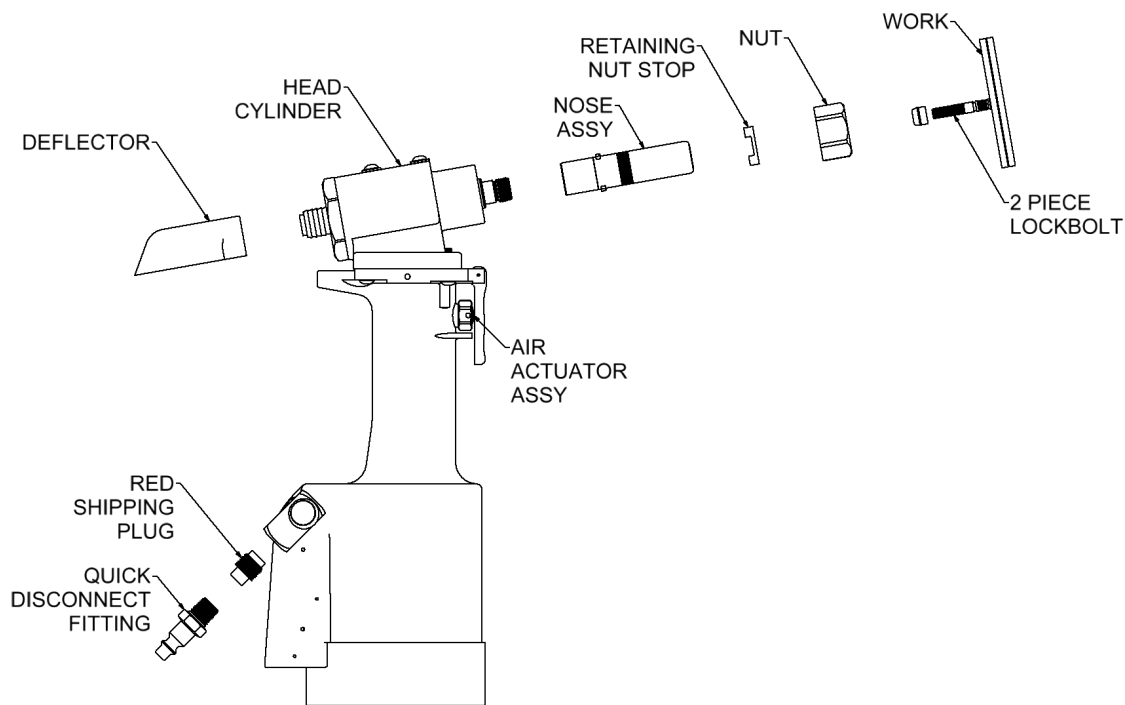

*Image may not reflect actual tool*

## DESCRIPTION

Covered under Patent No. 5,485,727

**WARNING:** The balance of the tool is designed for horizontal use and is not suited for any other application. Gage Bilt will be pleased to advise for your specific application.

The GB731OS is a pneumatic-hydraulic tool designed specifically for the efficient installation of a wide range of blind rivets and lockbolts. It weighs 5.75 lbs. (2.6 kg) and can be operated in any position with one hand. It has a .600" (15.24 mm) rivet setting stroke and a rated pull load of 4800 lbs (21.35 kN) with 90 psi (6.2 bar) air pressure at the air inlet.

The GB731OS riveter operates on a wide range of air pressure, with 90 to 100 psi (6.2-6.9 bar) providing the maximum efficiency. At 90 psi. (6.2 bar) air pressure, the GB731OS does not exceed 81.5 dB (A) and consumes 3.9 cfm at 20 cycles per minute.

The air inlet is provided with 1/4-18 female pipe threads for accepting the user's air hose fitting.

Nose Assemblies that were designed for the Model 352 Installation Tool mount directly on the GB731OS without the use of an adapter.

**NOSE ASSEMBLIES ARE NOT FURNISHED WITH THIS TOOL AND MUST BE ORDERED SEPARATELY.**

## MAINTENANCE

**WARNING:** Maintenance personnel **MUST** read and understand all warnings and cautions.

**WARNING:** Disconnect tool from its power source before performing maintenance.

**WARNING:** Excessive contact with hydraulic oil and lubricants should be avoided.

**WARNING:** Dispose of Hydraulic Oil in accordance with all environmental regulations applicable in your area.

**WARNING:** Read MSDS documents for all applicable materials.

The performance of any tool depends upon good maintenance practices. Following these minimal requirements for service and care will extend the life of your tool.

\*Only use an air supply set at 90-100 psi (6.2-6.9 bar) equipped with a filter-regulator to prevent wear.

\*The tool will eventually lose some hydraulic oil. Keep the hydraulic system full (only use Dexron III, or equivalent) and free of air by using the fill bottle assy (745163) on a weekly basis.

\*Proper care by operator is necessary in maintaining full productivity and reducing downtime. Read all applicable tool manuals and nose assembly data sheets prior to operating tools.

\*Keep nose assemblies, especially jaws, clean and free of chips and debris. Lube jaws and collet surfaces that jaws ride on with light machine oil on a daily basis.

\*All Screwed End Caps, Base Covers, Air Fittings, Actuators, Screws and Nose Assemblies are to be examined at the end of each working shift to check that they are secure.

\*Check tool, all hoses and all couplings daily for damage or air/hydraulic leaks. Tighten or replace (if necessary).

\*For a complete overhaul, tool kit GB731STK is recommended.

## CLEANING AND LUBRICATING PROCEDURE

Daily cleaning and lubrication of nose assembly will greatly reduce downtime and increase life of components. Using sewing machine oil, or an equivalent cleaner/lubricant, follow instructions below.

1. Disconnect tool vacuum line (if equipped).
2. Point nose assembly into oil as shown.
3. Cycle tool 8-10 times and wipe dry.

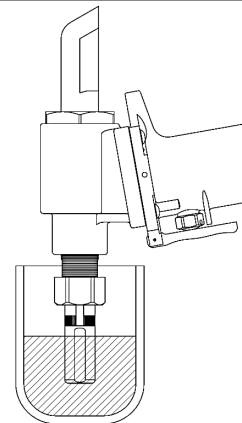

Image may not reflect actual tool

## TORQUE SPECIFICATIONS

Button Head Cap Screws (A-928) = 40 inch lbs.

Packing Plug (704118) = 45 foot lbs.

Flexlock Nut (400559) = 40 inch lbs.

Cap (731903) = 45 foot lbs.

Button Head Cap Screws (402482) = 35-40 inch lbs. (*Do NOT over-tighten*)



## FILLING AND BLEEDING INSTRUCTIONS

**NOTE:** Fill bottle Assy (745163) is required.

**WARNING:** Do not cycle tool without fill bottle assy (745163), or the button head cap screw (402482) and stat-o-seal (S572), installed in the head cylinder (731910). Severe personal injury may result.

**CAUTION:** Before filling handle assy (722132), the air piston assy (704121) should be all the way down.

**CAUTION:** When forcing piston rod assy (731333) downward with head cylinder (731910) removed, hydraulic oil will eject forcibly from handle assy.

**CAUTION:** Use CAUTION when removing button head cap screws (402482), stat-o-seals (S572) and 4oz fill bottle assy (745163). Hydraulic oil may be under pressure.

**WARNING:** Failure to follow these instructions carefully may result in severe personal injury.

To replace a small amount of oil in the tool, cycle tool to rear position disconnect air and follow steps 6-14 below.

Should it become necessary to completely refill the tool (as would be required after tool has been dismantled and reassembled), take the following steps.

1. Ensure air piston assy (704121) is at the full bottom of stroke by pushing piston rod assy (731333) down.
2. Fill power cylinder (731237) and oil passage (hole for o'ring S832 ) to the top, being careful not to get oil into the air passage.
3. Place gasket (704129) and o'ring (S832) on top of the handle assy (722132).
4. Push piston (731904) to rear of head cylinder (731910) until it stops. (DIM "B")
5. Press head cylinder (731910) down on top of handle assy (722132), being careful not to tear o'ring (S832) and gasket (704129) on top of handle assy (722132). Install button head cap screws (A-928) and torque evenly to 35-40 inch lbs.

**WARNING:** When replacing a small amount of oil, cycle tool to rear position. While still holding actuator lever assy (704343), disconnect air supply.

6. Remove front button head cap screw (402482) and stat-o-seal (S572) from top of head cylinder (731910). Attach 4oz. fill bottle assy (745163) making sure rear button head cap screw (402482) and stat-o-seal (S572) are in place.
7. Squeeze fill bottle assy (745163) gently until no air rises in the bottle.
8. Connect tool to air supply. Piston (731904) will then move to forward position. (DIM "A"). Cycle tool ten times.
9. Disconnect air supply, remove 4oz. fill bottle assy (745163) and replace button head cap screw (402482) and stat-o-seal (S572) and torque to 35-40 inch lbs.
10. Carefully remove button head cap screw (402482) and stat-o-seal (S572) from rear hole (**WARNING:** Rear hole could be under pressure.) and attach 4 oz. fill bottle assy (745163) to rear hole.
11. Tip tool forward approximately 45 degrees and squeeze fill bottle assy (745163). Continue until no air rises in fill bottle assy (745163) .

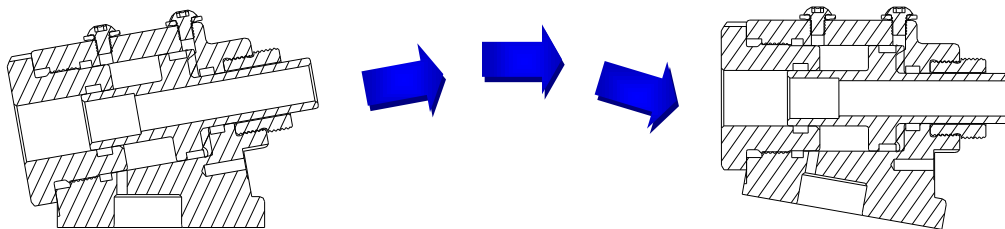

12. While tool is at 45 degrees, remove fill bottle assy (745163) and replace rear button head cap screw (402482) and stat-o-seal (S572) and torque to 35-40 inch lbs.
13. Connect tool to air supply and cycle tool ten times.
14. Check .600" (15.24 mm) stroke (we recommend using calipers). With the actuator lever assy (704343) released, check dimension (A). While holding actuator lever assy (704343) in, check dimension (B). Subtract dimension (A) from dimension (B). If stroke is not consistent within 1/64" (.0156" or .392 mm) repeat steps 6-14. (See figure below).

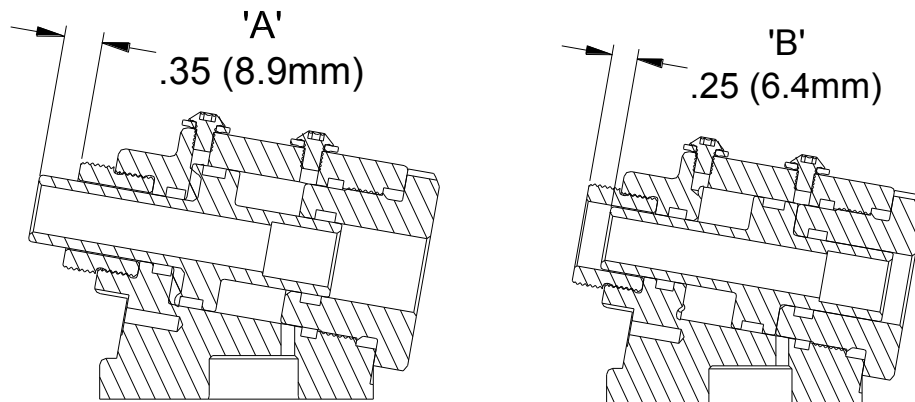

## TROUBLESHOOTING

Providing all maintenance conditions have been met, follow this systematic approach to diagnosis.

### 1. MORE THAN ONE PULL IS REQUIRED TO BREAK RIVET.

- a) Tool needs to be bled. (See filling and bleeding instructions.)
- b) Spring has fatigued, replace.
- c) Jaws are stripped or packed with chips. Clean or replace.
- d) Incorrect nose tip.

### 2. SLOW OR PARTIAL OPERATION WHEN THE ACTUATOR LEVER ASSY (704343) IS DEPRESSED

- a) O'Ring (A-1044) and back-up rings (401113) on piston (731904) could be worn or damaged. Replace.
- b) Back-up rings (731134) and o'ring (A-914) on the piston rod assy (731333) could be worn or damaged. Replace.
- c) Muffler (704146) or filter inside valve spool assy (703142) may be plugged with dirt. Clean thoroughly and back-blow with compressed air.
- d) Hole in metering screw in valve spool assy (703142) may be blocked or damaged. Hole diameter should be .028". Clear and size or replace.

### 3. NO OPERATION WHEN ACTUATOR LEVER ASSY (704343) IS DEPRESSED

- a) Tool seized due to mechanical failure or damaged parts.

### 4. OIL LEAKAGE

- a) **DO NOT** OPERATE WITH OIL LEAKING FROM TOOL. HIGH PRESSURE OIL MAY CAUSE SEVERE PERSONAL INJURY.
- b) Any oil leaking externally should be traced to its source. An o'ring or seal that leaks should be replaced.

### 5. AIR BYPASS FROM VALVE HOUSING

- a) If the spring (704141) breaks or dislodges, air will flow freely through the muffler (704146). Replace or reset. Valve spring installation tool (704162) is recommended.
- b) Check o'rings on valve sleeve (703139), valve spool assy (703142), and valve plug (704145). If worn or damaged, replace. Valve sleeve removal tool (704163) is recommended.

### 6. FASTENER STEM JAMMED IN NOSE ASSEMBLY

- a) Nose assembly components require service. **DISCONNECT AIR FROM TOOL**, remove the nose from the tool and disassemble. Replace worn or broken parts. Clean the surface the jaws ride on.
- b) Stems lodged side by side in the follower. Disassemble, remove stems, and reassemble.
- c) Incorrect follower.



## OVERHAUL

**WARNING:** Disconnect tool from its air source before performing overhaul.

**WARNING:** Tool must be maintained in a safe working condition at all times and examined on a daily basis for damage or wear. Any repair should be done by qualified personnel trained on Gage Bilt procedures.

**WARNING:** When operating, repairing or overhauling tool, wear approved eye protection. Do not look in front of tool or rear of tool when installing fastener.

**WARNING:** Depress actuator lever assy and disconnect from air, with the piston in the rear position, before overhaul. Severe personal injury may occur if air hose is not disconnected. **USE CAUTION** when forcing piston rod assembly downward with head cylinder removed. Hydraulic oil will eject forcibly from handle assy.

The disassembly and re-assembly procedure can be accomplished by utilizing the following instructions and drawings. Use extreme care during disassembly and re-assembly not to mar or nick any smooth surface that comes in contact with seals. Before installing seals, always apply a good lubricant, such as Lubriplate®, to the surfaces. It is recommended that tool kit (GB731STK) be used to facilitate overhaul. A complete overhaul can be achieved by the use of Service Kit (731007) which contains a complete set of o'rings, back-up rings, screws, washers and gasket.

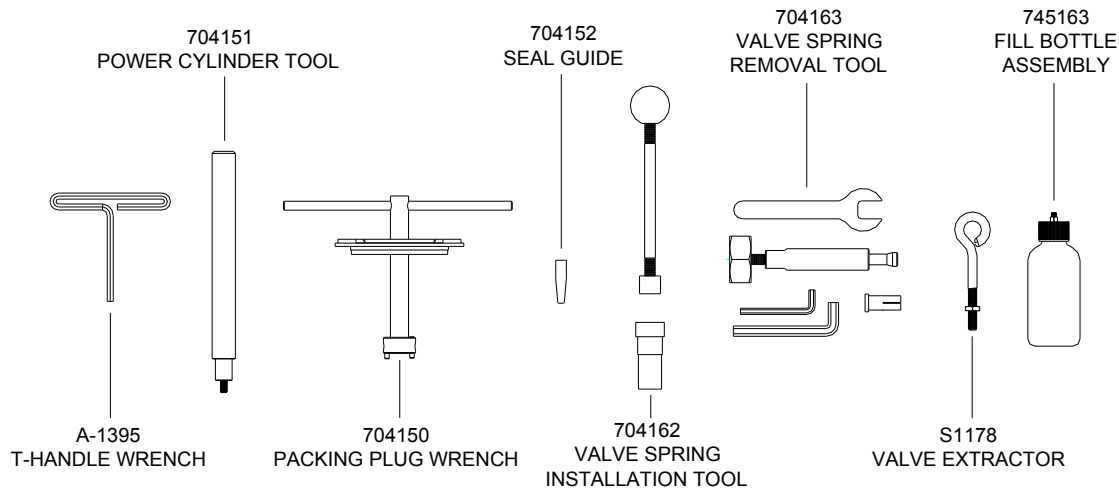

### GB731STK Service Tool Kit Includes:

Part No.	Description
A-1395	T-Handle Wrench
704150	Packing Plug Wrench
704151	Power Cylinder Tool
704152	Seal Guide
745163	Fill Bottle Assembly
S1178	Valve Extractor
704162	Valve Spring Installation Tool
704163	Valve Sleeve Removal Tool

## REMOVING 704130 AIR ACTUATOR ASSY

**CAUTION:** Air actuator assy can break if not careful.

1. Remove actuator lever assy (704343) including pin.
2. With actuator lever assy (704343) removed, insert a 5/8" (15.9 mm) open end box wrench around air actuator assy (704130).
3. Loosen the air actuator assy (704130).
4. Remove wrench. Unthread and remove the air actuator assy (704130) with fingers from the handle assy (722132).

## INSTALLING 704130 AIR ACTUATOR ASSY

**CAUTION:** Do not over tighten air actuator assy. Snug tighten only.

1. Apply Teflon® tape onto threads of air actuator assy (704130) one to two wraps.
2. Thread the air actuator assy (704130) all the way into handle assy (722132) with fingers.
3. Insert and turn 5/8" (15.9 mm) open end box wrench and snug tight approximately 1/4-1/2 turn.
4. Re-attach the actuator lever assy (704343) with pin.

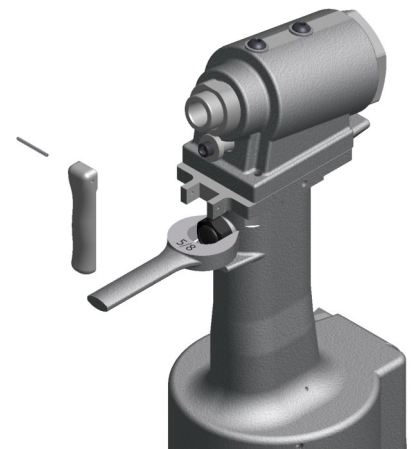

Image may not reflect actual tool

## HEAD

**WARNING:** Dispose of Hydraulic Oil in accordance with all environmental regulations applicable in your area.

Remove nose assembly from tool before attempting disassembly of head assy.

Remove end cap (731903). Push against piston (731904) to slide it out of rear of head cylinder (731910). Be careful not to damage threads or cause burrs on polished piston (731904) surface.

The re-assembly sequence is the opposite of disassembly. (See Filling and Bleeding instructions.) Apply Loctite® #242 and torque the four button-head cap screws (A-928) uniformly to 40 inch lbs. to prevent leakage around the gasket (704129).

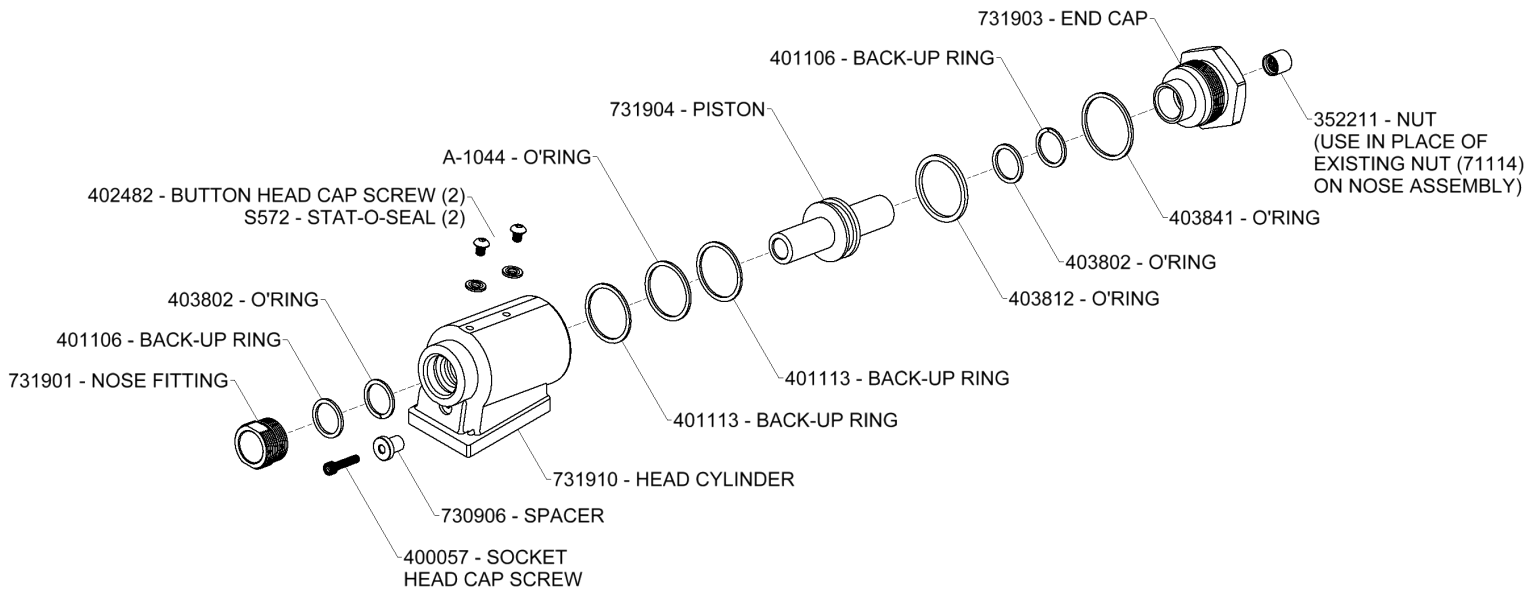

**NOTE:** Use nut (352211) in place of existing nut (71114) on nose assembly. Attach nut (352211) using tee wrench (A-291) supplied with tool.

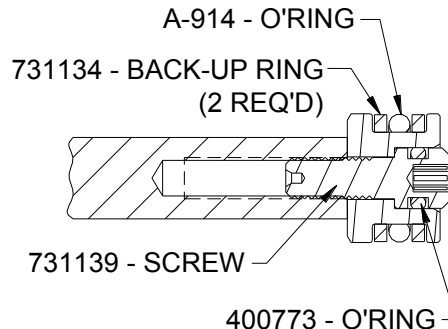

## HANDLE

To inspect air cylinder bore, remove base cover (704125). Any further disassembly will require removal of the head cylinder (731910) first. For complete disassembly, start by removing base cover (704125). Next, holding tool upright, remove four button-head cap screws (A-928). Lift head cylinder (731910) from handle assy (722132) and set aside o-ring (S832) and gasket (704129). Empty all hydraulic oil into an approved container and dispose of in accordance with all environmental regulations applicable in your area. Place piston rod wrench (730151) down into top of power cylinder (731237) and into slot of piston rod assy (731333). While holding this wrench, remove flexlock nut (400559) using a 7/16" socket wrench. Still holding piston rod wrench (730151), remove air piston assy (704121) using packing plug wrench (704150), by turning counterclockwise. When air piston assy (704121) is completely free from piston rod assy (731333), tap or push on the piston rod wrench (730151) to eject air piston assy (704121) from bottom of handle assy (722132). After removal of air piston assy (704121), slide piston rod assy (731333) back up to the end of its travel. Using packing plug wrench (704150) remove packing plug (704118). With packing plug (704118) removed, power cylinder (731237) can be removed by pushing on power cylinder tool (704151) when inserted into top of power cylinder (731237).

To reassemble the handle assy (722132), reverse the above procedure, being certain that all o-rings are properly lubricated before installation. Torque packing plug (704118) to 45 foot lbs. Attach the seal guide (704152) to the piston rod assy (731333) and tap the piston rod assy (731333) through the packing plug (704118). Attach air piston assy (704121) and flexlock nut (400559). Torque flexlock nut to 40 inch lbs. With the piston rod assy (731333) in the down position, fill oil passage on top of handle assy (722132) with automatic transmission oil, Dexron III or equivalent. When looking at top of handle assy (722132), the oil passage is the hole that has a counterbore for o-ring (S832). Replace gasket (704129) and o-ring (S832) just prior to replacing head cylinder (731910). (See Filling & Bleeding instructions).

## AIR VALVE

**WARNING:** Disconnect tool from its air source before disassembly.

To disassemble, first disconnect tool from its air source. Remove pin (704244) and muffler (704146). Insert valve extractor (S1178) into end of valve plug (704145) and pull it out. Using the same procedure, pull out valve spool assy (703142). NOTE: It should never be necessary to remove valve sleeve (703139) unless the ports in the valve sleeve (703139) are plugged from contaminated air. If ports are plugged, use needle nose pliers to grasp end of spring (704141), turning clockwise and pulling to dislodge from groove in casting. NOTE: Valve spring tool (704162) will facilitate the proper installation of the spring (704141), valve sleeve (703139) can be pulled out using valve sleeve removal tool (704163).

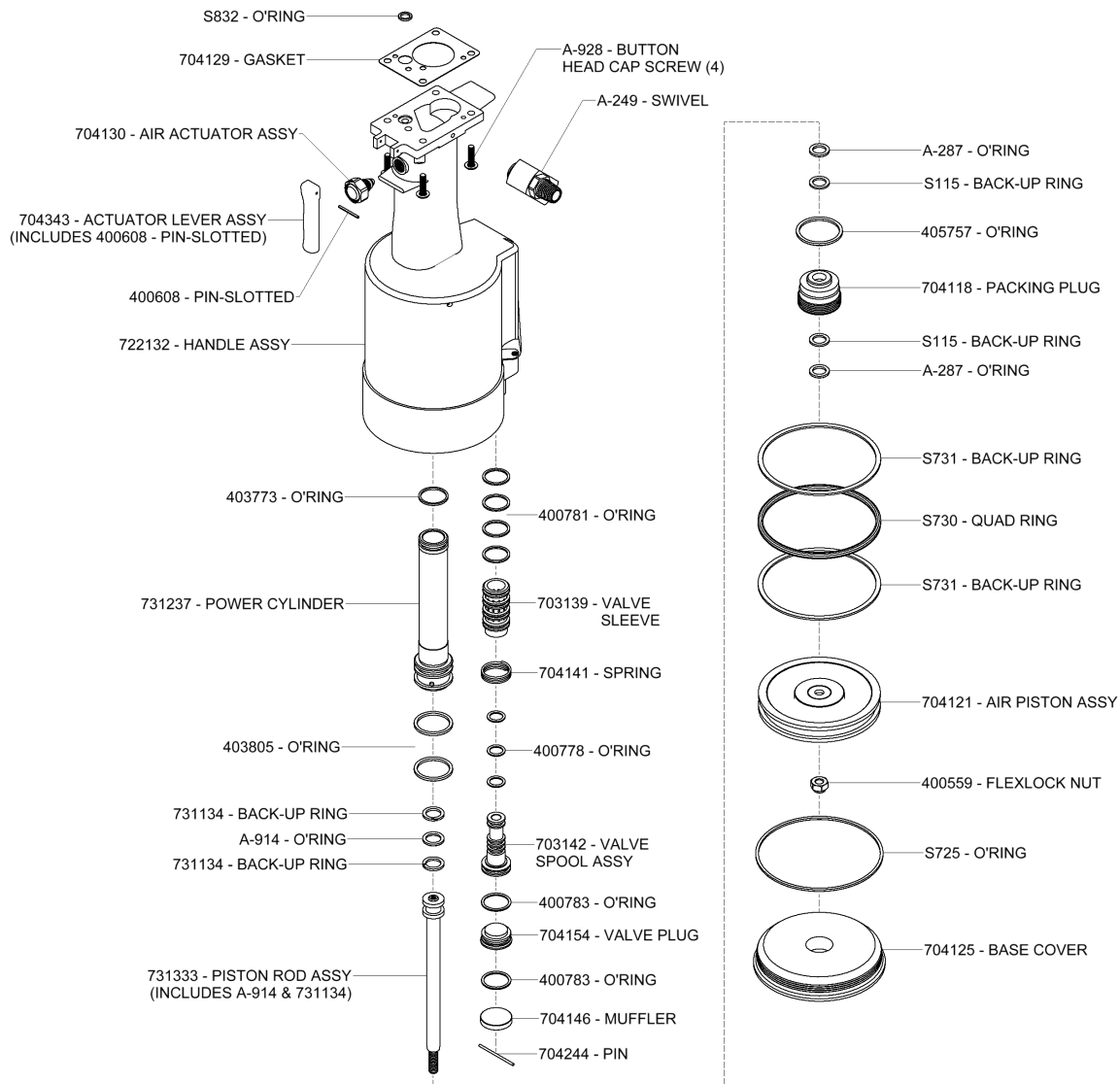

# DEXRON® III OIL SAFETY DATA

## FIRST AID MEASURES

**Eye:** No specific first aid measures are required. As a precaution, remove contact lenses, if worn, and flush eyes with water.

**Skin:** No specific first aid measures are required. As a precaution, remove clothing and shoes if contaminated. To remove the material from skin, use soap and water. Discard contaminated clothing and shoes or thoroughly clean before reuse.

**Ingestion:** No specific first aid measures are required. Do not induce vomiting. As a precaution, get medical advice.

**Inhalation:** No specific first aid measures are required. If exposed to excessive levels of material in the air, move the exposed person to fresh air. Get medical attention if coughing or respiratory discomfort occurs.

**Note to Physicians:** In an accident involving high-pressure equipment, this product may be injected under the skin. Such an accident may result in a small, sometimes bloodless, puncture wound. However, because of its driving force, material injected into a fingertip can be deposited into the palm of the hand. Within 24 hours, there is usually a great deal of swelling, discoloration, and intense throbbing pain. Immediate treatment at a surgical emergency center is recommended.

## FIRE

Leaks/ruptures in high pressure system using materials of this type can create a fire hazard when in the vicinity of ignition sources (eg. open flame, pilot lights, sparks, or electric arcs).

### FLAMMABLE PROPERTIES:

**Flashpoint:** (Cleveland Open Cup) 178 °C (352 °F) Minimum

**EXTINGUISHING MEDIA:** Use water fog, foam, dry chemical or carbon dioxide (CO<sub>2</sub>) to extinguish flames.

### PROTECTION OF FIRE FIGHTERS:

**Fire Fighting Instructions:** This material will burn although it is not easily ignited. See Section 7 for proper handling and storage. For fires involving this material, do not enter any enclosed or confined fire space without proper protective equipment, including self-contained breathing apparatus.

**Combustion Products:** Highly dependent on combustion conditions. A complex mixture of airborne solids, liquids, and gases including carbon monoxide, carbon dioxide, and unidentified organic compounds will be evolved when this material undergoes combustion.

## ACCIDENTAL RELEASE MEASURES

**Protective Measures:** Eliminate all sources of ignition in vicinity of spilled material.

**Spill Management:** Stop the source of the release if you can do it without risk. Contain release to prevent further contamination of soil, surface water or groundwater. Clean up spill as soon as possible. Use appropriate techniques such as applying non-combustible absorbent materials or pumping. Where feasible and appropriate, remove contaminated soil. Place contaminated materials in disposable containers and dispose of in a manner consistent with applicable regulations.

## ECOLOGICAL INFORMATION

**Waste disposal:** In accordance with all environmental regulations applicable to your area.

**Spillage:** Prevent entry into drains, sewers and water course. Soak up with diatomaceous earth or other inert material. Store in appropriate container for disposal.

**Ecotoxicity:** This material is expected to be harmful to aquatic organisms and may cause long-term adverse effects in the aquatic environment. The ecotoxicity hazard is based on an evaluation of data for the components or a similar material.

## HANDLING

**Precautionary Measures:** DO NOT USE IN HIGH PRESSURE SYSTEMS in the vicinity of flames, sparks and hot surfaces. Use only in well ventilated areas. Keep container closed. Keep out of the reach of children.

**General Handling Information:** Avoid contaminating soil or releasing this material into sewage and drainage systems and bodies of water.

**Static Hazard:** Electrostatic charge may accumulate and create a hazardous condition when handling this material. To minimize this hazard, bonding and grounding may be necessary but may not, by themselves, be sufficient. Review all operations which have the potential of generating and accumulating an electrostatic charge and/or a flammable atmosphere (including tank and container filling, splash filling, tank cleaning, sampling, gauging, switch loading, filtering, mixing, agitation, and vacuum truck operations) and use appropriate mitigating procedures.

## DISPOSAL CONSIDERATIONS

Use material for its intended purpose or recycle if possible. Oil collection services are available for used oil recycling or disposal. Place contaminated materials in containers and dispose of in a manner consistent with applicable regulations.

# GB731OS - SELECTION CHART

FASTENER	DIA.	STANDARD	STRADDLE NOSE (1)	LONG
LOCKBOLT, NAS SHEAR PULL TYPE, NAS TENSION PULL TYPE, NASS = SHEAR & GP NAST = TENSION	5/32"	NAST05-204C-25OS	NAST05-204C-30OS	NAST05-204C-34OS
	3/16"	NASS05-204C-25OS	NASS05-204C-30OS	NASS05-204C-34OS
	1/4"	NAS06-204C-25OS	NAS06-204C-30OS	NAS06-204C-34OS
		NAS08-204C-25OS	NAS08-204C-30OS	NAS08-204C-34OS
MGP®	4mm	MGP4-204C-25OS	MGP4-204C-30OS	MGP4-204C-34OS
	5mm	MGP5-204C-25OS	MGP5-204C-30OS	MGP5-204C-34OS
LGP® Light weight Groove Proportion LOCKBOLT	5/32"	LGP05-204C-25OS	LGP05-204C-30OS	LGP05-204C-34OS
	3/16"	LGP06-204C-25OS	LGP06-204C-30OS	LGP06-204C-34OS
	7/32"	LGP07-204C-25OS	LGP07-204C-30OS	LGP07-204C-34OS
	1/4"	LGP08-204C-25OS	LGP08-204D-30OS	LGP08-204C-34OS
MLGP®	4mm	MLGP4-204C-25OS	MLGP4-204C-30OS	MLGP4-204C-34OS
	5mm	MLGP5-204C-25OS	MLGP5-204C-30OS	MLGP5-204C-34OS
BLIND RIVET (SINGLE ACTION) WITH OR W/O DRIVE WASHER NAS1900 S & U SERIES	1/8"	SMLS04-204D-27OS		SMLS04-204D-37OS
	5/32"	SMLS05-204D-27OS		SMLS05-204D-37OS
	3/16"	SMLS06-204D-27OS		SMLS06-204D-37OS
	1/4"	SMLS08-204D-27OS		SMLS08-204D-37OS
BLIND BOLT (SINGLE ACTION) WITH OR W/O DRIVE WASHER MS90353S & U / MS90354S & U MS21140S & U / MS21141S & U CR7000 SERIES, BACB30YY, YU, & YT	5/32"	SB05-204D-27OS		SB05-204D-37OS
	3/16"	SB06-204D-27OS		SB06-204D-37OS
	1/4"	SB08-204D-27OS		SB08-204D-37OS
EN6122 & UAB130-EU EN6127 & UAB6127-EU EN6128 & UAB100-EU EN6129 & UABP-EU	3/16"	UBB06-204D-27OS		UBB06-204D-37OS
	1/4"	UAB08-204D-27OS		UAB08-204D-37OS
BACR15FR/FP, BACR15GF/GK, NAS1900 S & U SERIES BLIND RIVET WITH DRIVE WASHER NAS9301-9312	1/4"	08MAX-204D-27OS		08MAX-204D-37OS
"A" CODE NAS1398A & NAS1399A	1/8"	4A-204D-27OS		4A-204D-37OS
	5/32"	5A-204D-27OS		5A-204D-37OS
	3/16"	6A-204D-27OS		6A-204D-37OS
	1/4"	SMLS08-204D-27OS		SMLS08-204D-37OS
ASP® 2, ASP PF, ASP 4 FF, ASP 2 F, ASP 2 LC	13/64"	ASP06-204D-27OS		ASP06-204D-37OS
	17/64"	ASP08-204D-27OS		ASP08-204D-37OS
	21/64"	ASP10-204D-27OS		ASP10-204D-37OS
NAS1719, NAS1720, NAS1721 & MBC	1/8"	MBC04-204D-27OS		MBC04-204D-37OS
	5/32"	MBC05-204D-27OS		MBC05-204D-37OS
	3/16"	MBC06-204D-27OS		MBC06-204D-37OS
GROUND STUD, BACS53B 2	13/64"	GS8-204D-32OS		GS8-204D-42OS
	17/64"	GS10-204D-32OS		GS10-204D-42OS

MGP®, LGP®, MLGP®, AND ASP® ARE REGISTERED TRADEMARKS OF ALCOA INC.

## GAGE BILT CERTIFIES THE GB731OS WILL INSTALL THE ABOVE FASTENERS

1) -30 STRADDLE NOSES ARE DESIGNED TO REACH OVER THE COLLAR.

2) BACS53B -10 ONLY

NOTE: THE LAST 2 DIGITS OF THE NOSE ASSEMBLY REPRESENTS THE LENGTH  
THE NOSE ASSEMBLY EXTENDS FROM THE TOOL. (I.e. -27 = 2.7 inches)

9/14

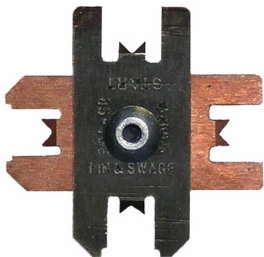

**GAGE BILT ALSO SUPPLIES PIN & COLLAR SWAGE INSPECTION  
GAGES TO CERTIFY CORRECT SWAGE INSTALLATION.**



## DECLARATION OF CONFORMITY

**MANUFACTURER:** Gage Bilt Inc. 44766 Centre Ct. Clinton Twp. Michigan (586-226-1500)

**WE DECLARE THAT THE EQUIPMENT SPECIFIED HEREIN CONFORMS  
TO THE FOLLOWING DIRECTIVES AND STANDARDS**

Machinery Directive 2006/42/EC

EN12100-1 & EN12100-2

EN792-1:2000+A1

**EU REPRESENTATIVE:** Edgar Hausmann GmbH Förster-Busch-Str. 10 D-34346 Hann. Münden Germany

**EQUIPMENT DESCRIPTION:** GB7310S FASTENER INSTALLATION TOOL

This product specified above conforms to the above directives and standards.

SIGNATURE:



NAME: BRIAN LEIGH  
PRODUCT MANAGER  
CLINTON TWP., MI U.S.A.  
MAY 2010  
(586) 226-1500

### WARRANTY

Seller warrants that all goods covered by this catalog will conform to applicable specifications and will replace or repair, F.O.B. our plant, any goods providing defective from faulty workmanship, or material, for 6 months from date of shipment.

Said warranty to remain in effect if, and only if, such goods are used in accordance with all instructions as to maintenance, operation and use, set forth in manuals and instruction sheets furnished by seller.

Sellers obligation under this warranty shall be limited to the repair or rework of the goods supplied or replacement thereof, at Seller's option, and in no case is to exceed the invoice value of said goods. Under no circumstances will the seller be liable for incidental or consequential damages or for damages incurred by the buyer or subsequent user in repairing or replacing defective goods or if the goods covered by this warranty are reworked or subjected to any type of additional processing.

This warranty is void if Seller is not notified in writing of any rejections or defects within 6 months after the receipt of the material by the customer.

**THIS WARRANTY IS MADE IN LIEU OF ALL OTHER WARRANTIES  
EXPRESSED OR IMPLIED, INCLUDING MERCHANTABILITY.**