

ADAPTER DATA SHEET

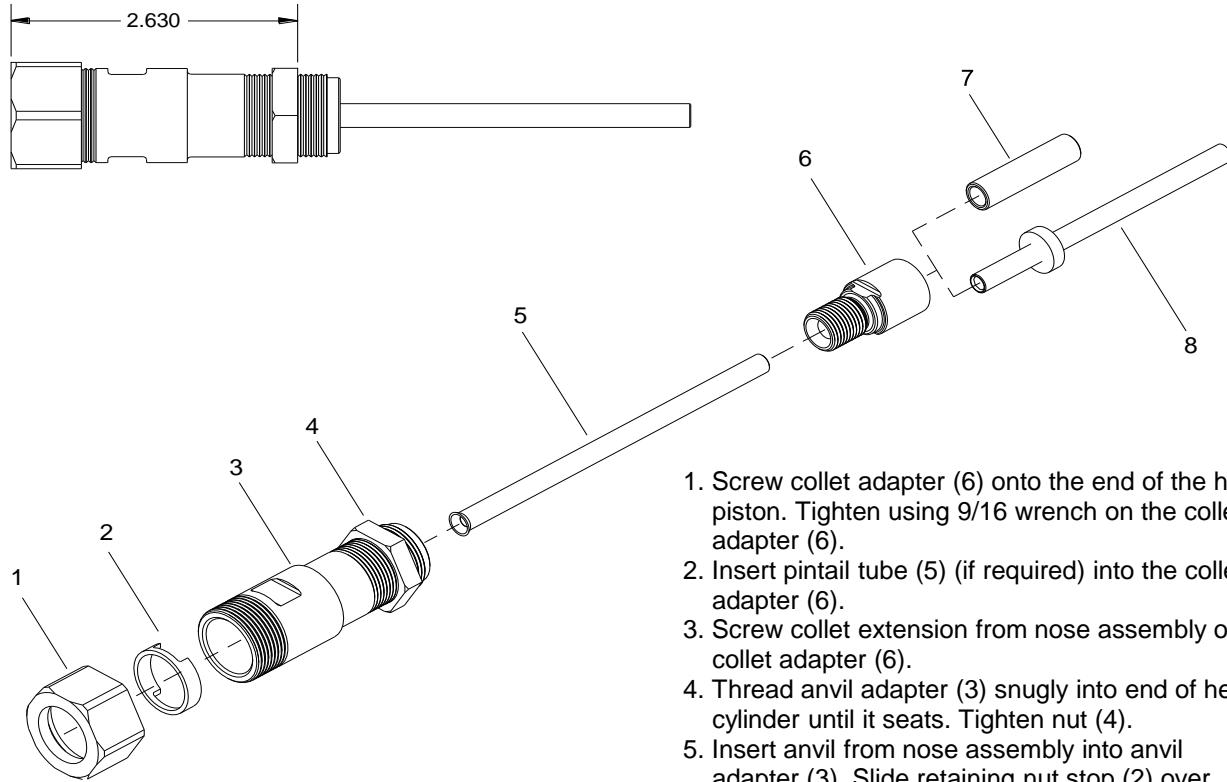

1. Screw collet adapter (6) onto the end of the head piston. Tighten using 9/16 wrench on the collet adapter (6).
2. Insert pintail tube (5) into the collet adapter (6).
3. Screw collet extension from nose assembly onto collet adapter (6).
4. Thread anvil adapter (3) snugly into end of head cylinder until it seats. Tighten nut (4).
5. Insert anvil from nose assembly into anvil adapter (3). Slide retaining nut stop (2) over anvil and tighten nut (1).

NOTE: Remove pintail tube (5) for all right angle, offset and for 1/4" straight applications.

NOTE: Use pintail tube (8) for 1/4" blind rivets straight applications only.

NOTE: Use pintail tube (7) for lockbolts, straight applications only.

1/00 REV. 7/04

Ref. No.	Qty.	Description	Part Number
1	1	Nut	223001
2	1	Retaining Stop Nut	240102
3	1	Anvil Adapter	70325
4	1	Jam Nut	70820
5	1	Pintail Tube	200506
6	1	Collet Adapter	70326
7	1	Pintail Tube	703011-1
8	1	Pintail Tube	40893

Type: Adapter	Adapts: 352 Series Nose Assemblies to GB703 Tool	Tool: GB703 GB734 GB743
-------------------------	---	---

<h1>GAGE BILT</h1>	GAGE BILT Inc. 44766 Centre Court (586) 226-1500 Clinton Twp. MI 48038 (586) 226-1505 Fax e-mail:solutions@gagebilt.com / www.gagebilt.com	Adapter
		703352