

GB731

INSTALLATION TOOL

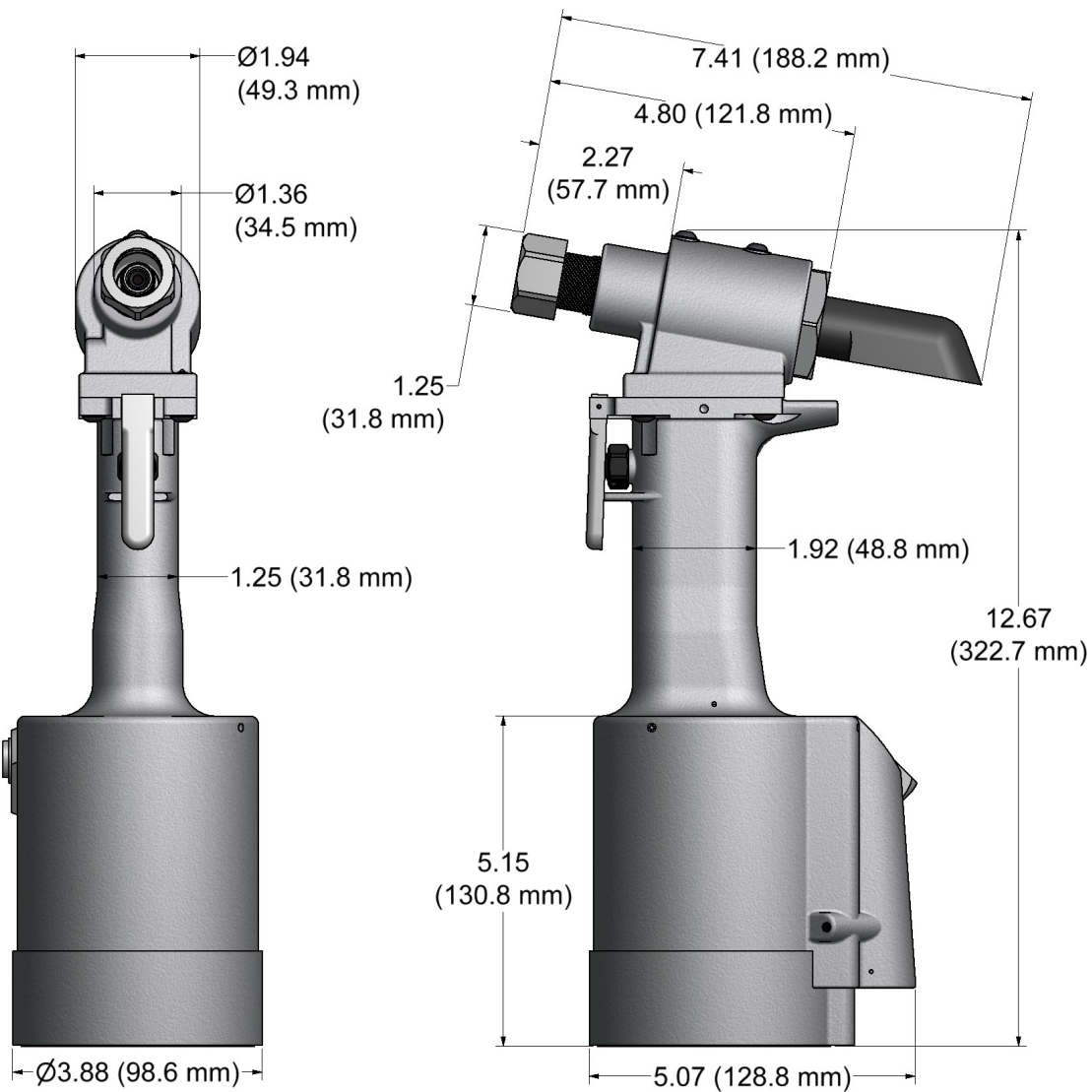

DESCRIPTION

The GB731 is a pneumatic-hydraulic tool designed specifically for the efficient installation of a wide range of blind rivets and lock-bolts. It weighs just under 5.75 lbs. (2.61 kg) and can be operated in any position with one hand. It has a .600 (15.24 mm) rivet setting stroke and a rated pull load of 4,800 lbs. (21.35 kN) on 90 psi (6.2 bar) air pressure at the air inlet.

The GB731 riveter operates on 90 to 100 psi (6.2-6.9 bar) of air pressure, providing the maximum efficiency. At 90 psi. (6.2 bar) of air pressure, the GB731 does not exceed 81.5 dB (A) and consumes 3.9 cfm at 20 cycles per minute.

The air inlet is provided with 1/4-18 female pipe thread for accepting the user's air hose fitting.

NOSE ASSEMBLIES ARE NOT FURNISHED WITH THIS RIVETER AND MUST BE ORDERED SEPARATELY.



GB731-NOSE ASSEMBLY SELECTION CHART & ACCESSORIES



ACCESSORIES (SOLD SEPARATELY)

NOSE ASSEMBLIES (SOLD SEPARATELY)

CATCHER BAG

#704214 (Equivalent to #670A20)



NAS LOCKBOLTS AND BLIND FASTENERS

#GB105093 (EQUIVALENT TO #105093)



GRIP GAGE FOR CHERRYMAX® AND CHERRYLOCK® RIVETS #269G3

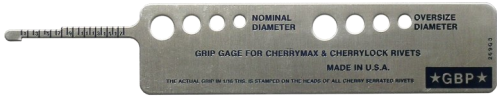

GAGE BILT ALSO SUPPLIES PIN & COLLAR SWAGE INSPECTION GAGES TO CERTIFY CORRECT SWAGE

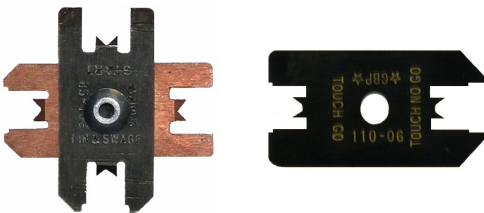

STRAIGHT

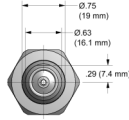

**OFFSET

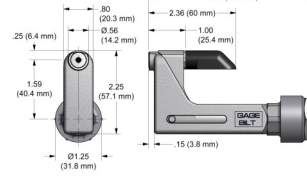

*RIGHT ANGLE

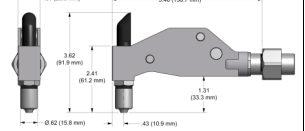

FASTENER	DIA.	STRAIGHT	*RIGHT ANGLE ¹	**OFFSET	
'A' CODE NAS1398 & NAS1399 'A'	3/32 1/8 5/32 3/16 1/4	3A-352B-25 4A-752C-20 5A-752C-20 6A-752B-20 SMLS08-713-20	4A-752C-45 5A-752C-45 6A-752B-45 SMLS08-713-45	3A-751B-54RA ₅ 4A-751B-54RA ₅ 5A-751B-54RA ₅ 6A-751B-54RA ₅ SMLS08-752A-43OS	4A-752A-43OS 5A-752A-43OS 6A-752A-43OS SMLS08-752A-43OS
ASP® 2 ASP & ASP PF ASP FF & ASP F ASP-LC & MAF	13/64 17/64	ASP06-752B-20 ASP08-752B-20	ASP06-752B-45 ASP08-752B-45	ASP06-751B-54RA ₅ ASP08-751B-54RA ₅	ASP06-752A-43OS ASP08-752A-43OS
LGP® LOCKBOLT LGPL2SC-V BACB30VM LGPL18SC-V BACB30XT LGPL4SC-V ABS0548 LGPL2SP-V BACB30VN LGPL4SP-V ASNA2392 LGPL8SC-V BACB30WD LGPL9SC-V BACB30WB LGPL9SP-V BACB30VY	5/32 3/16 7/32 1/4	LGP05-2480-10 LGP05-2480-45 LGP06-2480-10 LGP06-2480-45 LGP07-731-10 LGP07-731-45 LGP08-2480-10 LGP08-2480-45	LGP05-2480-20 LGP06-2480-20 LGP06-2480-45 LGP07-731-20 LGP07-731-45 LGP08-2480-20	LGP05-204C-25OS LGP05-204C-34OS LGP06-204C-25OS LGP06-204C-34OS LGP07-204C-25OS LGP07-204C-34OS LGP08-204C-25OS LGP08-204C-34OS	LGP05-204C-30OS LGP06-204C-30OS LGP07-204C-34OS LGP07-204C-30OS LGP08-204D-30OS LGP08-204C-30OS
NAS and GP® SHEAR/TENSION LOCKBOLTS BACB30TY BACB30UA BACB30TZ BACB30UB BACB30DY BACB30GX BACB30DX BACB30GP BACB30GO BACB30GY BACB30GW	5/32 3/16 1/4 ³	NASS05-2480-10 NASS05-2480-20 NASS05-2480-45 NAS06-2480-10 NAS06-2480-45 NAS08-2480-10 NAS08-2480-45	NAST05-2480-10 NAST05-2480-20 NAST05-2480-45 NAS06-2480-20 NAS08-2480-20	NASS05-204C-25O NASS05-204C-30O NASS05-204C-34O NAS06-204C-25OS NAS06-204C-34OS NAS08-204C-25OS NAS08-204C-34OS	NAST05-204C-25O NAST05-204C-30O NAST05-204C-34O NAS06-204C-30OS NAS08-204D-30OS
CHERRYMAX®, CHERRYMAX® 'AB', MBC® LOCK CREATOR BACR15FR/FP, BACR15GF/GK, NAS1900 S & U SERIES BLIND RIVET WITH DRIVE WASHER	1/8 5/32 3/16 1/4	456MAX-X-751-23 ₂ 456MAX-751A-61 ₂ 08MAX-752B-20	456MAX-751A-61 ₂ 08MAX-752B-45	456MAX-751D-54RA _{2,5}	456MAX-X-731-43OS ₂
BLIND BOLT (SINGLE ACTION) WITH OR W/OUT DRIVE WASHER	1/8 5/32 3/16 1/4	SMLS04-752C-20 SB05-752C-20 SB05-752C-80 SB06-752B-20 SB06-752B-80 SB08-713-20	SMLS04-752C-45 SB05-752C-45 SB06-752B-45	SB05-751B-54RA ₅ SB06-751B-54RA ₅ SB08-713A-58RA	SB05-752A-43OS SB06-204D-27OS SB08-204D-37OS
EN6122 & UAB130-EU EN6127 & UAB6127-EU EN6128 & UAB100-EU EN6129 & UABP-EU	1/8 5/32 3/16 1/4	UAB568-713-21 ₄	UAB568-713-61 ₄	UBB06-751B-54RA ₅	UAB04-752A-43OS UBB06-752A-43OS UAB08-204D-27OS UAB08-204D-37OS
BLIND RIVET (SINGLE ACTION) WITH OR W/OUT DRIVE WASHER NAS1900 S & U SERIES	1/8 5/32 3/16 1/4	SMLS04-752C-20 SMLS05-752C-20 SMLS06-752B-20 SMLS08-713-20	SMLS04-752C-45 SMLS05-752C-45 SMLS06-752B-45 SMLS08-713-45	SMLS04-751B-54RA ₅ SMLS05-751B-54RA ₅ SMLS06-751B-54RA ₅ SMLS08-713B-58RA	SMLS04-752A-43OS SMLS05-752A-43OS SMLS06-752A-43OS SMLS08-752A-43OS

ASP®, LGP®, AND GP® ARE REGISTERED TRADEMARKS OF ALCOA INC. CHERRYMAX® AND MBC® ARE REGISTERED TRADEMARKS OF CHERRY AEROSPACE FASTENERS.

GAGE BILT CERTIFIES THE GB731 WILL INSTALL THE ABOVE FASTENERS

<p>**ALL OFFSET 204 SERIES NOSES REQUIRE 751204 ADAPTER</p> <p>1) RIGHT ANGLE NOSE ASSEMBLIES MAY REQUIRE MORE THAN ONE FULL.</p> <p>2) INSTALLS 1/8, 5/32 & 3/16 DIAMETERS.</p> <p>3) NOT FOR TENSION ALLOY OR TITANIUM</p> <p>4) INSTALLS 5/32, 3/16 & 1/4 DIAMETERS.</p> <p>5) RIGHT ANGLE NOSE REQUIRES 731154 STROKE LIMITER.</p>	<p>PLEASE NOTE: Due to lever assembly length, the GB731SR Tools require -45 min. nose length for all straight noses.</p>
--	---

NOTE: THE LAST 2 DIGITS OF THE NOSE ASSEMBLY REPRESENTS THE LENGTH THE NOSE EXTENDS FROM THE TOOL. I.E. -20 = 2.0 INCHES