

NOSE ASSEMBLY DATA SHEET

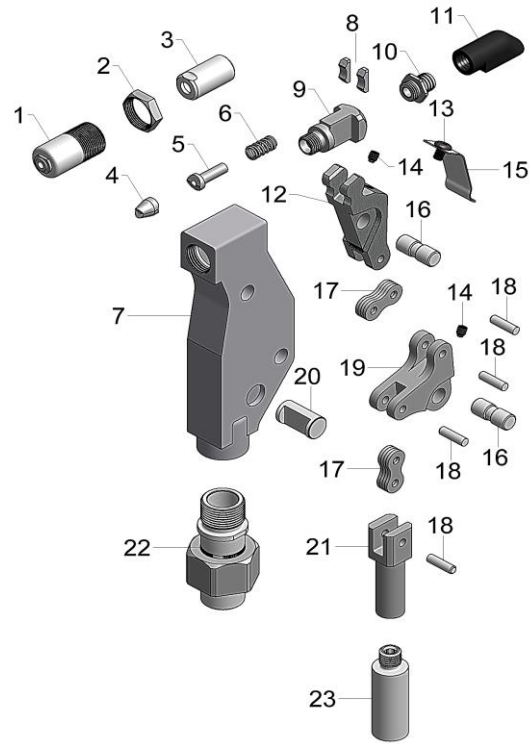
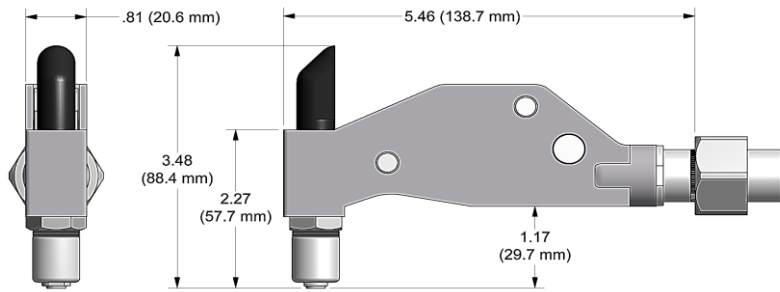

CAUTION!

Do not operate if pintail deflector is removed. Pintail may eject forcibly. SEVERE PERSONAL INJURY MAY RESULT.

- *GB731 USE 731154 STROKE LIMITER.
- **RECOMMENDED FOR MAINTENANCE APPLICATIONS ONLY.
- ***RIGHT ANGLE NOSE ASSEMBLIES REQUIRE MORE THAN ONE "PULL".



6/15

GAGE BILT

GAGE BILT Inc.

44766 Centre Court (586) 226-1500
 Clinton Twp. MI 48038 (586) 226-1505 Fax
 e-mail:solutions@gagebilt.com / www.gagebilt.com

Type:	Fasteners:	Recommended Tool: GB751
Self-Releasing Front Ejecting 1/8", 5/32" & 3/16" Ø	CHERRYMAX®, CHERRYMAX® 'AB', MBC® LOCK CREATOR BACR15FR/FP, BACR15GF/GK,	
		Alternate Tool: *GB731

Ref. No.	Qty.	Description	456MAX-751D-54RA
1	1	Sleeve Assy	10420
2	1	Jam Nut	70411
3	1	Collet	20513
4	1	Jaw Set	30513
5	1	Follower	40506
6	1	Spring	50425
7	1	Frame	75310
8	2	Shoe Bearing	75311
9	1	Drawbolt-Collet	70486-1
10	1	Barbed Retainer	70575
11	1	Deflector	61107
12	1	Lever	75313
13	1	Button Head Cap Screw	402471
14	2	Set Screw	75315
15	1	Guard	75316
16	2	Pivot Pin	75317
17	8	Link	75318
18	4	Link Pin	75319
19	1	Bellcrank	75320
20	1	Guide Pin	75321
21	1	Drawbolt	75322
22	1	Adapter Assy	70459
23	1	Extension-Collet	70463

ATTACHMENT:

Disconnect air supply from tool. Hold back of drawbolt-collet (9) down with thumb. Thread sleeve assy (1) into frame (7) until it bottoms out on collet (3). Loosen approximately 1/4 turn and tighten jam nut (2) securely to frame (7). Engage one or two threads of collet extension (23) onto piston assy located on tool, then insert adapter assy (22) into end of head cylinder assy located on tool and turn clockwise until snug. Rotate nose assembly to desired position and tighten adapter assy (22) securely. Reconnect air supply to tool.

DISASSEMBLY:

Loosen jam nut (2) and remove sleeve assy (1). Unscrew collet (3) which contains jaw assy (4) from drawbolt-collet (9).

Remove button head cap screw (13) and guard (15). Remove two set screws (14) and push out two pivot pins (16) to permit removal of linkage. Shoe bearings (8) and drawbolt-collet (9) will disengage from lever (12).

Remove four link pins (18) to disassemble lever (12), links (17), bellcrank (19) and drawbolt (21).

Remove guide pin (20) from frame (7). Adapter Assy (22) is secured to frame with Loctite® and need not be removed unless damaged.

REASSEMBLY:

Reverse the procedure. Linkage, consisting of lever (12), links (17), bellcrank (19) and drawbolt (21) should be assembled as a subassembly before inserting lever (12) into shoe bearings (8) and drawbolt-collet (9). MAKE SURE NOTCHES ON DRAWBOLT-COLLET (9) ARE POINTING TOWARDS LEVER (12). This complete subassembly may then be inserted into frame (7) and retained by guide pin (20) and pivot pins (16).