

NOSE ASSEMBLY DATA SHEET

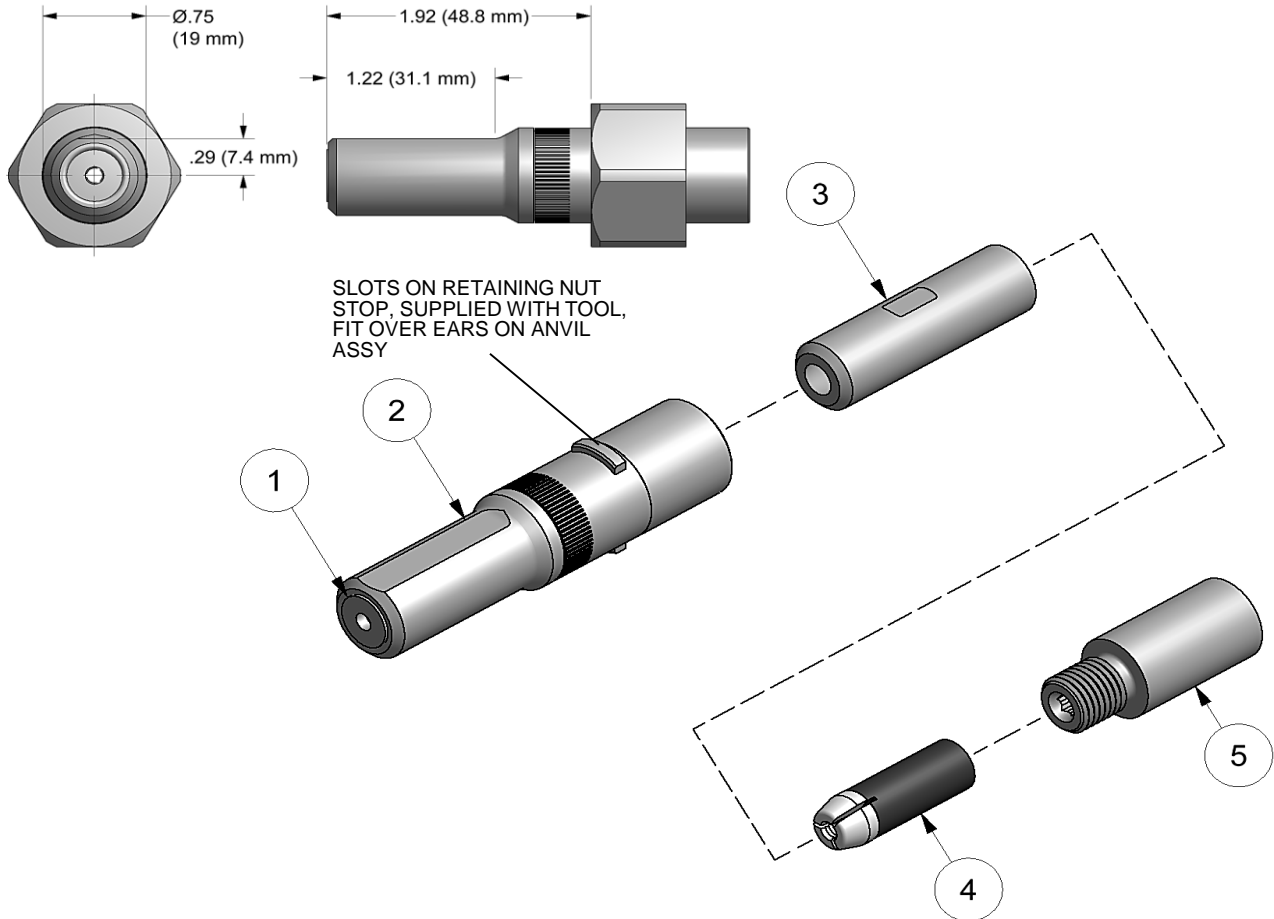

Use Hex-Key in rear of piston for nose assembly attachment.

Use Hex-Key in rear of collet extension for collet disassembly.

Rev.1/15

**Anvil Assembly consists of #1 and 35208 retainer.

GAGE BILT

GAGE BILT Inc.

44766 Centre Court (586) 226-1500
 Clinton Twp., MI 48038 (586) 226-1505 Fax
 e-mail:solutions@gagebilt.com / www.gagebilt.com

Type:		Fastener:	Recommended Tool:
Non Self-Releasing *3/16" Ø		NUT PLATE RIVETS MS20600 SERIES CCR224/264/274 MS/9SP/PT BACR15CC/CF/DA/DR	GB752
			Alternate Tools: GB751 & GB2480(A)
Ref. No.	Qty.	Description	6C-752B-20
1	1	Anvil-Driving	16030
2	1	Anvil Assy (Inc. #1)	12346
3	1	Collet	20717
4	1	Super-Grip Jaw Assy	30656-S
5	1	Extension-Collet	70550