

NOSE ASSEMBLY DATA SHEET

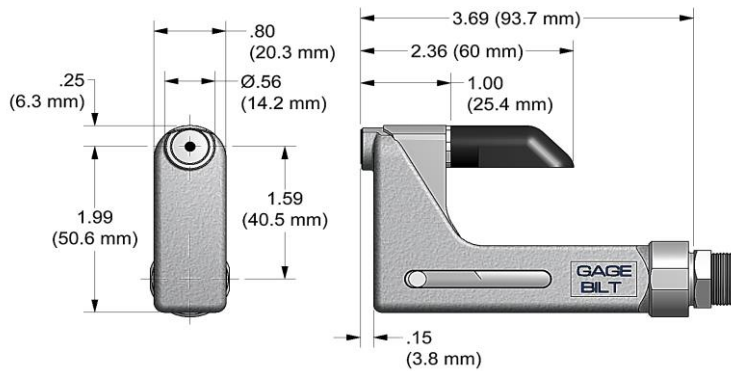

CAUTION:
Do not operate if pintail deflector is removed. Pintail may eject forcibly. SEVERE PERSONAL INJURY MAY RESULT.

Attachment

Screw nose assembly onto tool until it stops then back off until nose is in desired position. (Warning: do not back off nose assembly more than one complete turn). Lock jam nut (70411) against adapter (70341)

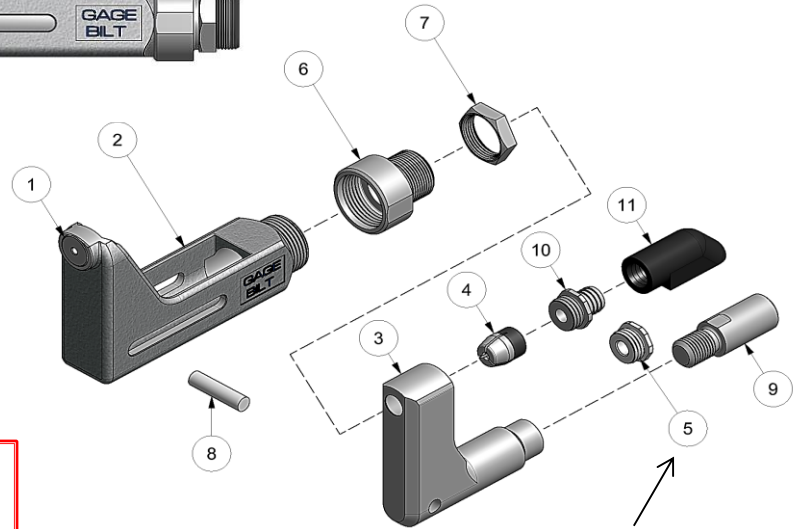

Cap (5) is used for closed access applications only or when clearance is an issue.

WARNING:
KEEP FINGERS AND HANDS AWAY FROM NOSE ASSEMBLY DURING OPERATION TO PREVENT SEVERE PERSONAL INJURY.



3/07 REV. 4/15

GAGE BILT

GAGE BILT Inc.

44766 Centre Court (586) 226-1500
Clinton Twp. MI 48038 (586) 226-1505 Fax
e-mail:solutions@gagebilt.com / www.gagebilt.com

| Type: | | Fasteners: | Recommended Tool: |
|------------------------------|------|---|--------------------------|
| Non Self-Releasing 1/8" Ø | | MS20600, Cherry® 9000 Huck® PT, SP & MS RV200 & RV500 | GB715 |
| | | | Alternate Tools: GB51 |
| Ref. No. | Qty. | Description | 4C-715-400S |
| 1 | 1 | Anvil Insert | 10487 |
| 2 | 1 | Anvil & Holder Assy (Inc. #1) | 13370 |
| 3 | 1 | Collet | 20911 |
| 4 | 1 | Super-Grip Jaw Assy | 30425-S2 |
| 5 | 1 | Cap | 60428 |
| 6 | 1 | Anvil Adapter | 70341 |
| 7 | 1 | Jam Nut | 70411 |
| 8 | 1 | Pin | 70468 |
| 9 | 1 | Collet Adapter | 70340 |
| 10 | 1 | Barbed Retainer | 60440 |
| 11 | 1 | Deflector | 61107 |