

# NOSE ASSEMBLY DATA SHEET

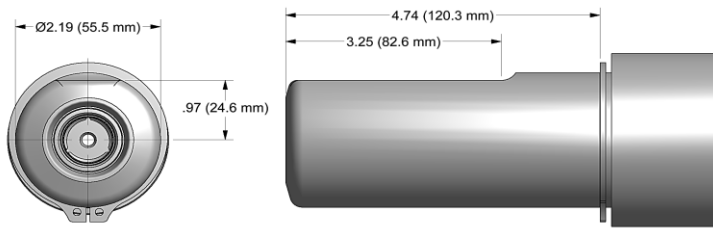

1. Ensure Piston is in full forward position.
2. Disconnect tool control cord.
3. Screw assembled Collet onto Piston until top of collet flat lines up with Adapter face of tool.
4. If Collet Lock (10) is not in Piston groove, continue to turn 1/4 turn, or less until lock engages groove.
5. Tighten Set Screw (11) on (new noses).
6. Slide Anvil (1) over assembled Collet. Install Split Ring, Sleeve (furnished with tool) and Retaining Ring (14).

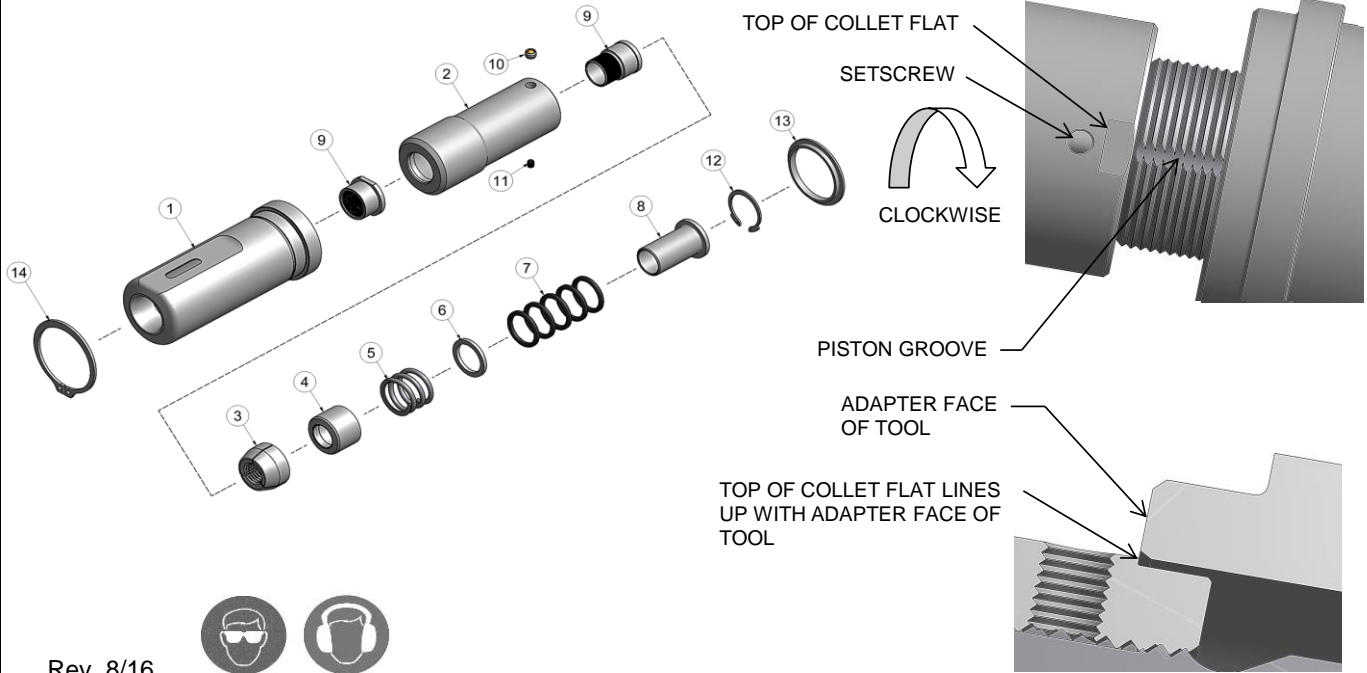

Rev. 8/16

**GAGE BILT**  
MADE in USA

44766 Centre Court Clinton Twp. MI 48038 USA  
Ph: +1 (586) 226-1500 Fax: +1 (586) 226-1505  
solutions@gagebilt.com / www.gagebilt.com

Type:		Fastener:	Recommended Tool:
Self-Releasing 3/4" Ø		C50L®	GB585
			Alternate Tools: Model 585 or Model 586
Ref. No.	Qty.	Description	<b>24-585-46</b>
1	1	Anvil	12401
2	1	Collet Assy (Inc. 9,10 & 11)	22400
3	1	Jaw Set	32401
4	1	Follower	42401
5	1	Spring	52010
6	1	Spacer	55020
7	5	O'Ring	400846
8	1	Sleeve	62006
9	1	Release & Ejector Kit	82400
10	1	Collet Lock	54502
11	1	Socket Set Screw	A-280
12	1	Retaining Ring	402263
13	1	Sleeve-Collet Lock	62402
14	1	Retaining Ring	401027
15	1	Collet Assy (Inc. 2 thru 11)	92400