

# NOSE ASSEMBLY DATA SHEET

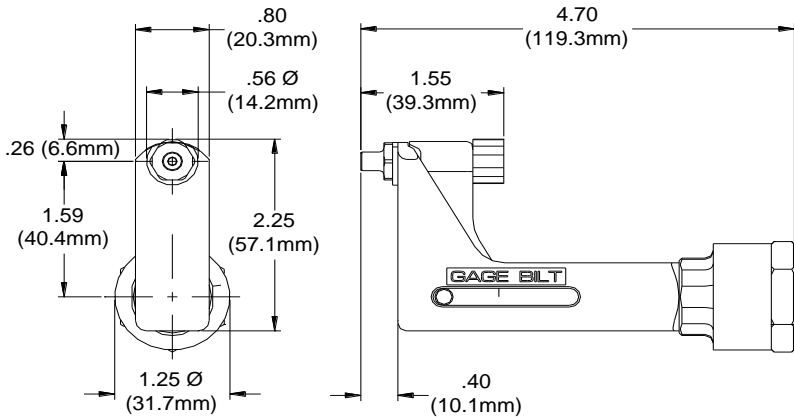

**CAUTION:**  
Pintail may eject forcibly. Use for closed access applications only to prevent SEVERE PERSONAL INJURY!

**Attachment:**

Screw jam nut (70336) onto nose fitting of tool at least 3/4". Screw nose assembly onto nose fitting of tool until it stops, then back off until nose is in desired position. (Warning: Do not back off nose assembly more than one complete turn). Lock jam nut (70336) against adapter (70331).

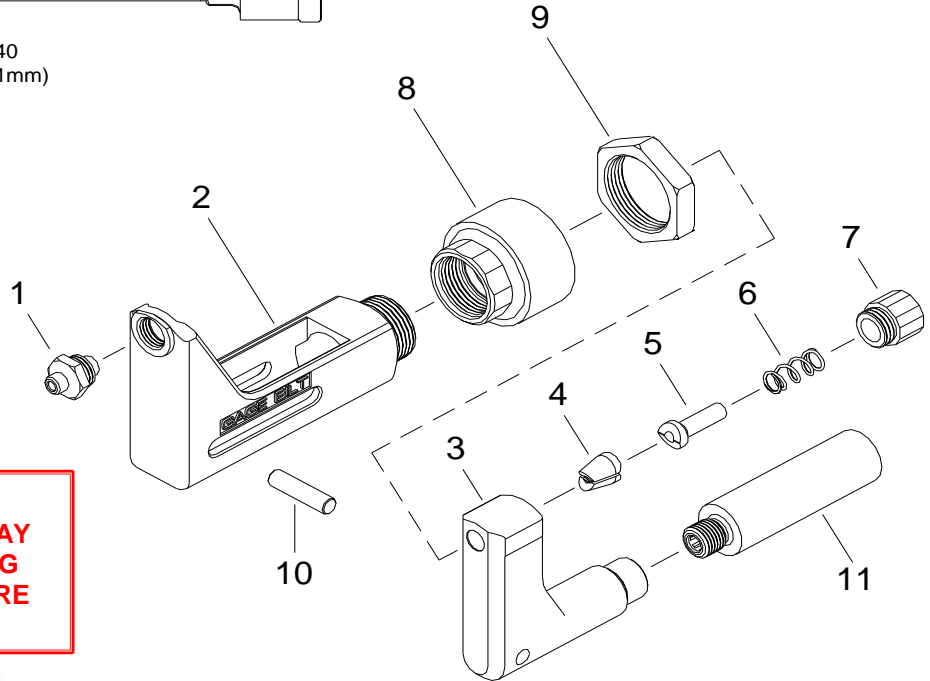

**WARNING:**  
KEEP FINGERS AND HANDS AWAY FROM NOSE ASSEMBLY DURING OPERATION TO PREVENT SEVERE PERSONAL INJURY.



10/07 Rev. 10/14

\*USE ADAPTER 745751 & DO NOT USE # (9) JAM NUT 70336.

**GAGE BILT**  
MADE IN U.S.A.

**GAGE BILT Inc.**

44766 Centre Court (586) 226-1500  
Clinton Twp. MI 48038 (586) 226-1505 Fax  
e-mail:solutions@gagebilt.com / www.gagebilt.com

Type:		Fasteners:		Recommended Tool:
Non Self-Releasing 3/32" Ø		NUT PLATE RIVETS MS20600-MS20605		GB751
				Alternate Tools: GB752, GB722, GB2480 & *GB745
Ref. No.	Qty.	Description	3NP 751-430S	
1	1	Nose Tip	10231	
2	1	Anvil Holder	13368	
3	1	Collet	20914	
4	1	Jaw Set	30617	
5	1	Follower	40506	
6	1	Spring	50418	
7	1	Cap	60429	
8	1	Anvil Adapter	70331	
9	1	Jam Nut	70336	
10	1	Pin	70468	
11	1	Collet Adapter	70332	