

NOSE ASSEMBLY DATA SHEET

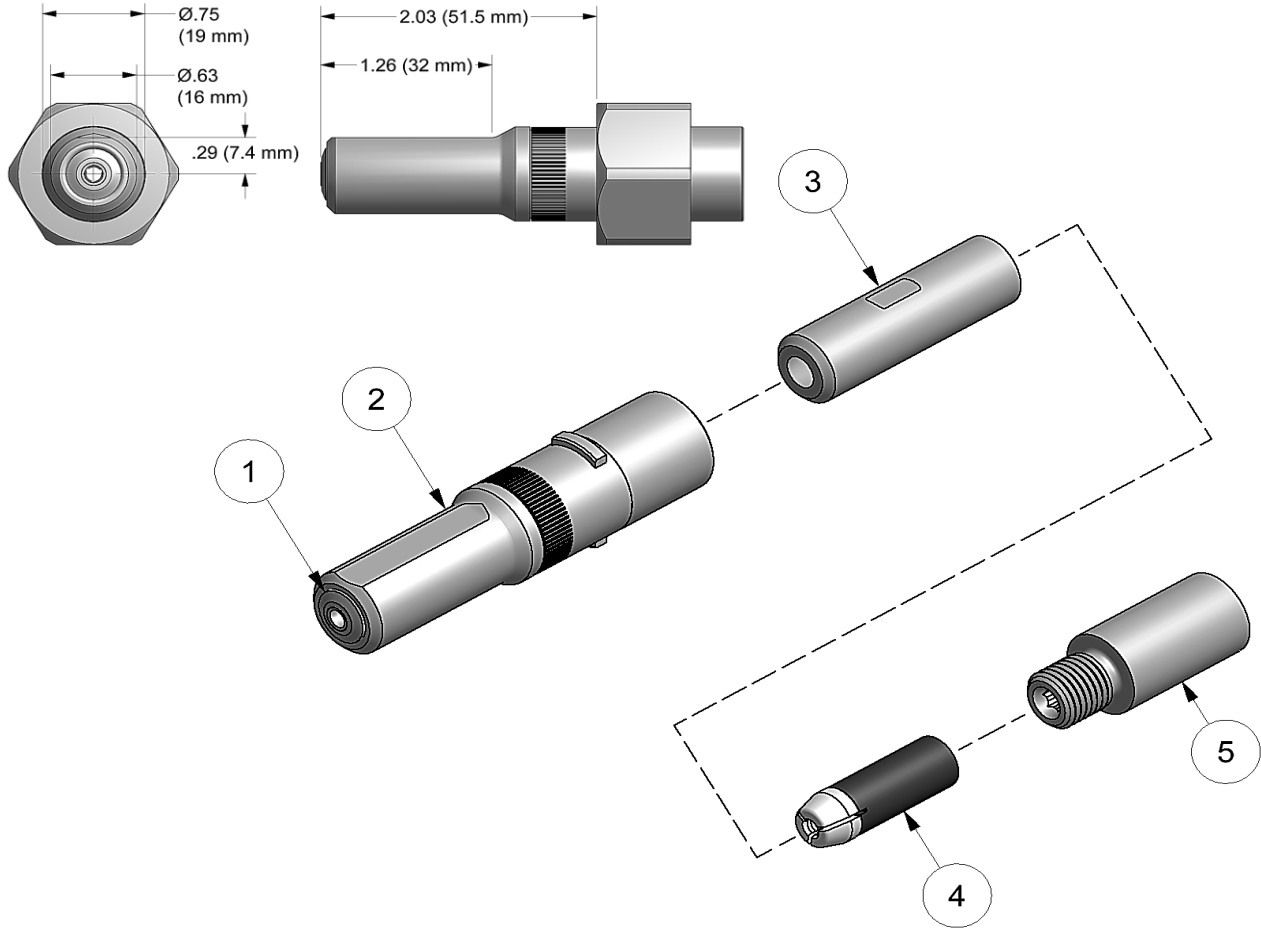

Use Hex-Key in rear of piston for nose assembly attachment.

Use Hex-Key in rear of collet extension for collet disassembly.

11/01 REV 12/15

**Anvil Assembly consists of #1 and 35208 retainer.

GAGE BILT

GAGE BILT Inc.

44766 Centre Court (586) 226-1500
 Clinton Twp., MI 48038 (586) 226-1505 Fax
 e-mail:solutions@gagebilt.com / www.gagebilt.com

Type:		Fastener:	Recommended Tool:
Non Self-Releasing *3/16" \varnothing		NAS1398A/NAS1399A RV1000/RV1100 & RV1200 *1/4 \varnothing AF5075 / AF5076 / S149A020	GB752
			Alternate Tools: GB751 & GB2480(A)
Ref. No.	Qty.	Description	6A-752B-20
1	1	Anvil-Driving	16028
2	1	Anvil Assy (Inc. #1)	17762
3	1	Collet	20717
4	1	Super-Grip Jaw Assy	30656-S
5	1	Collet Extension	70550