

NOSE ASSEMBLY DATA SHEET

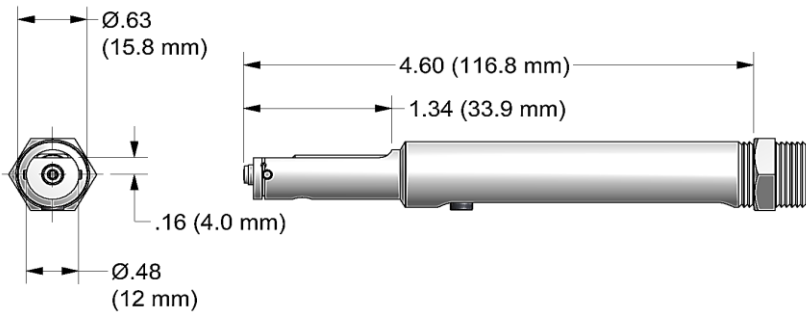

**POINT NOSE ASSEMBY DOWN
WHEN ATTACHING TO TOOL**



Effective FOD Control (foreign object damage/debris). Install catcher bag on the front of the riveter to catch spent pintail stems. Place nose assembly through grommet on catcher bag and easily fasten catcher bag to tool using the Velcro strap. Features an easily emptied zippered pouch.

Use catcher bag 500610 for XX-51-46 straight nose assemblies

Catcher bag sold separately

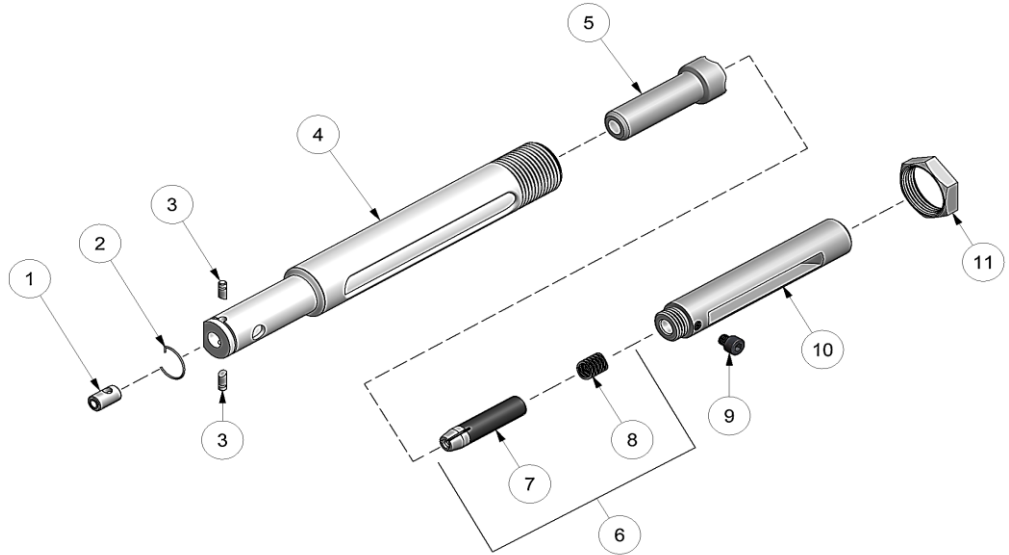

1/99 Rev. 5/16

GAGE BILT
MADE IN U.S.A.

GAGE BILT Inc.

44766 Centre Court +1 (586) 226-1500
Clinton Twp., MI 48038 +1 (586) 226-1505 Fax
e-mail:solutions@gagebilt.com / www.gagebilt.com

Type:	Fasteners:	Recommended Tool:
Single Action Non Self-Releasing 1/8" Ø	NAS1398A/1399A NAS1738A/1739A RV1000/1100 & 12000	GB50
		Alternate Tools: GB51 & GB715

Ref. No.	Qty.	Description	4A-51-46
1	1	Anvil Insert	10154
2	1	Retaining Ring	50308
3	2	Ratchet Pin	15520
4	1	Anvil Holder	10318
5	1	Collet	20326
6	1	Jaw Assy (Incl. 7 & 8)	30428-A1
7	1	Super Grip Jaw Assy	30428-CS
8	1	Wave Spring	A-1614
9	1	Socket Head Cap Screw	70303
10	1	Drawbolt	70301
11	1	Jam Nut	70411