

NOSE ASSEMBLY DATA SHEET

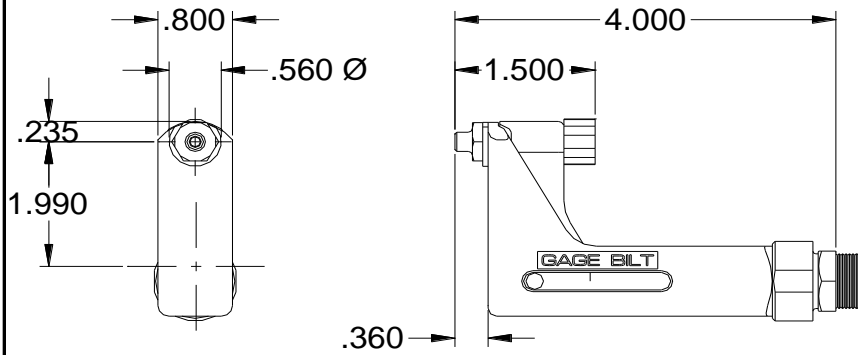

Attachment:

Screw nose assembly onto tool until it stops then back off until nose is in desired position.

(Warning: do not back off nose assembly more than one complete turn.) Lock in place with jam nut (70411) against face of tool.

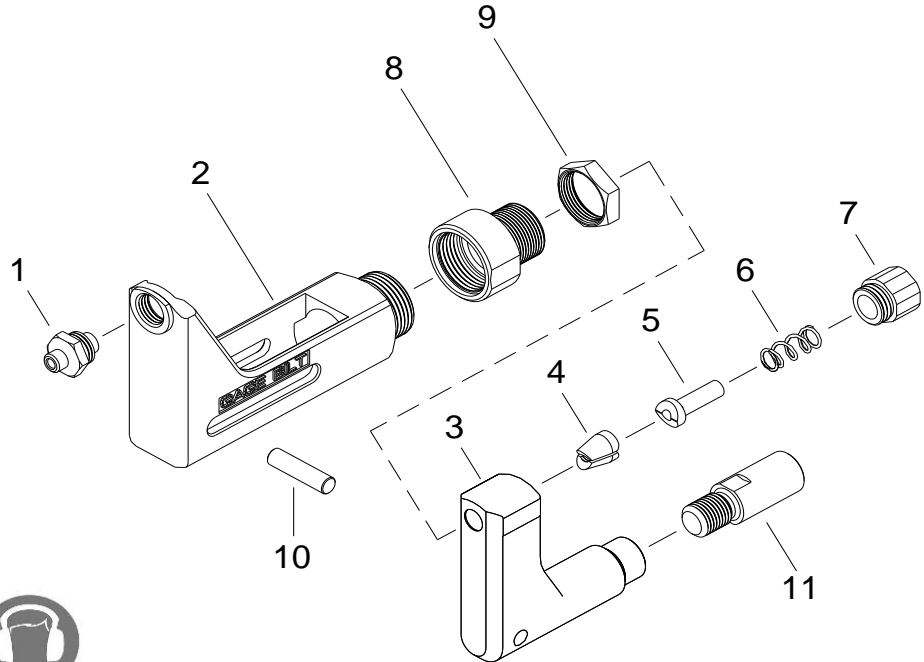

Rev. 4/14



GAGE BILT
MADE IN U.S.A.

GAGE BILT Inc.

44766 Centre Court (586) 226-1500
Clinton Twp, MI 48088 (586) 226-1505 Fax
e-mail:solutions@gagebilt.com / www.gagebilt.com

Type:		Fasteners:				Recommended Tool: GB715	
Non Self-Releasing 3/32", 1/8", 5/32" & 3/16" Ø		N, Q & E POP®, CLOSED END AVEX® & COMMERCIAL RIVETS					
Ref. No.	Qty.	Description	3N-715-400S	4N-715-400S	5N-715-400S	6N-715-400S	
1	1	Nose Tip	10247	10202	12277	12278	
2	1	Anvil Holder	13368	13368	13368	13368	
3	1	Collet	20914	20914	20914	20914	
4	1	Jaw Set	30617	30617	30617-1	30617-1	
5	1	Follower	40506	40506	40506	40304-2	
6	1	Spring	50418	50418	50418	A-1503	
7	1	Cap	60429	60429	60429	60429	
8	1	Anvil Adapter	70341	70341	70341	70341	
9	1	Jam Nut	70411	70411	70411	70411	
10	1	Pin	70468	70468	70468	70468	
11	1	Collet Adapter	70340	70340	70340	70340	