

NOSE ASSEMBLY DATA SHEET

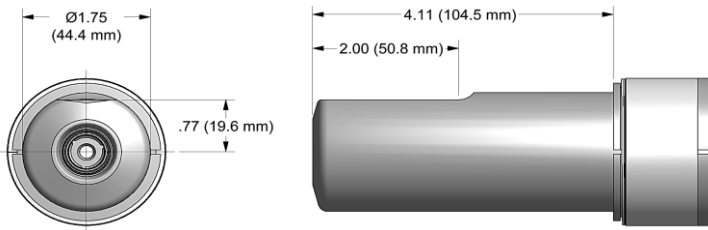

1. Ensure Piston is in full forward position.
2. Disconnect tool control cord.
3. Slide sleeve (13) over collet. Screw assembled collet onto piston until top of collet flat lines up with adapter face of tool.
4. If Collet Lock (10) is not in Piston groove, continue to turn 1/4 turn clockwise, or less, until lock engages groove.
5. Tighten Set Screw (11).
6. Slide Anvil (1) over assembled Collet. Install Split Ring, Sleeve and retaining ring (furnished with tool).

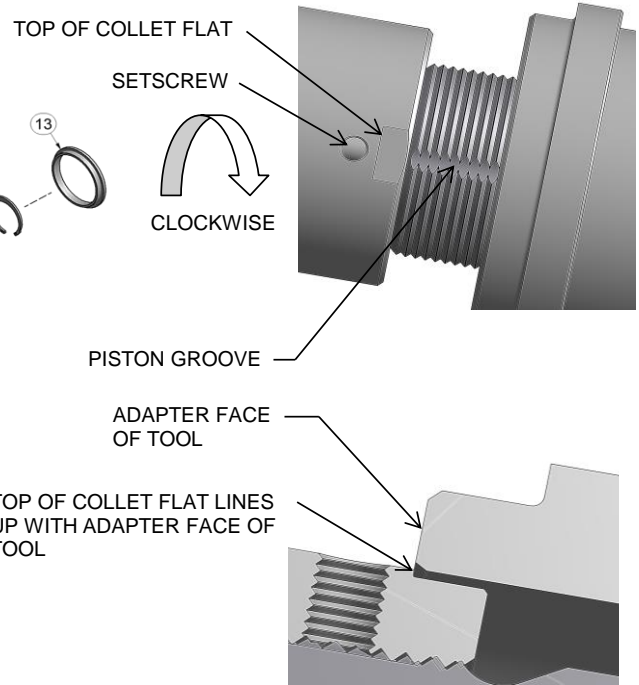
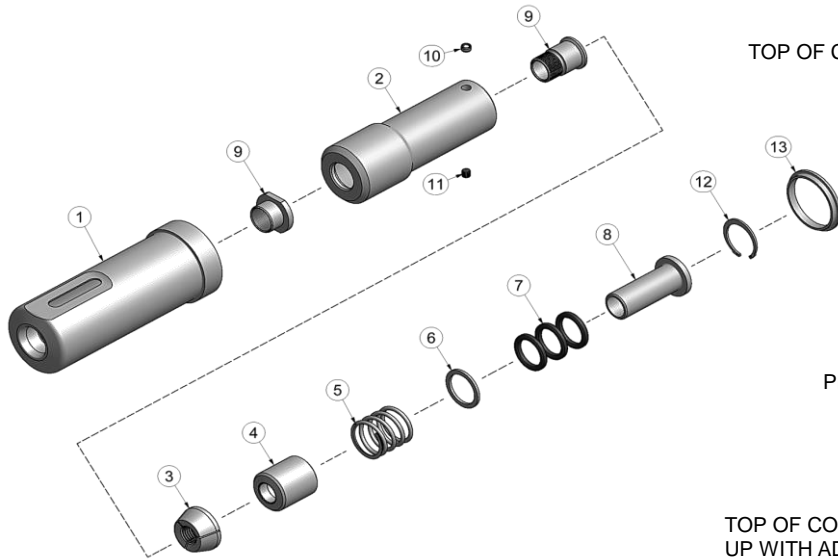

2/10 Rev 8/16



GAGE BILT
MADE in USA

44766 Centre Court Clinton Twp. MI 48038 USA
Ph: +1 (586) 226-1500 Fax: +1 (586) 226-1505
solutions@gagebilt.com / www.gagebilt.com

Type:		Fastener:	Recommended Tool:
Self-Releasing 1/2" Ø		C50L®	GB2620
Ref. No.	Qty.	Description	16-2620-41
1	1	Anvil	11601
2	1	Collet Assembly (Inc. 9,10 & 11)	21600
3	1	Jaw Set	31601
4	1	Follower	41605
5	1	Spring	51601
6	1	Spacer	55016
7	3	O'Ring	406455
8	1	Sleeve	61613
9	1	Release & Ejector Kit	81600
10	1	Ball Lock Assembly	54501
11	1	Set Screw	51605
12	1	Retaining Ring	402259
13	1	Sleeve-Collet Lock	61602