

NOSE ASSEMBLY DATA SHEET

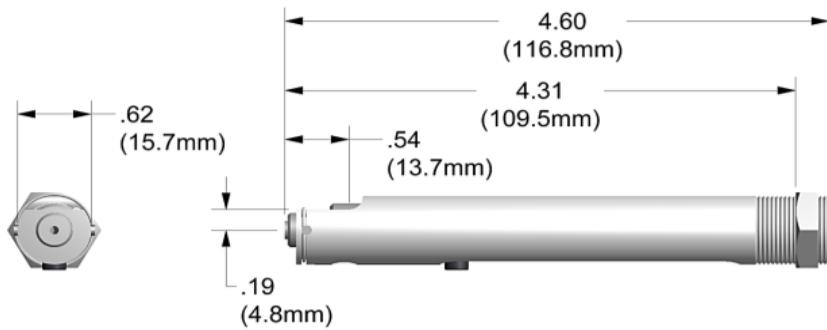

Effective FOD Control (foreign object damage/debris). Install catcher bag on the front of the riveter to catch spent pintail stems. Place nose assembly through grommet on catcher bag and easily fasten catcher bag to tool using the Velcro strap. Features an easily emptied zippered pouch.

Use catcher bag 715610 for XX-715-43 straight nose assemblies

Catcher bag sold separately

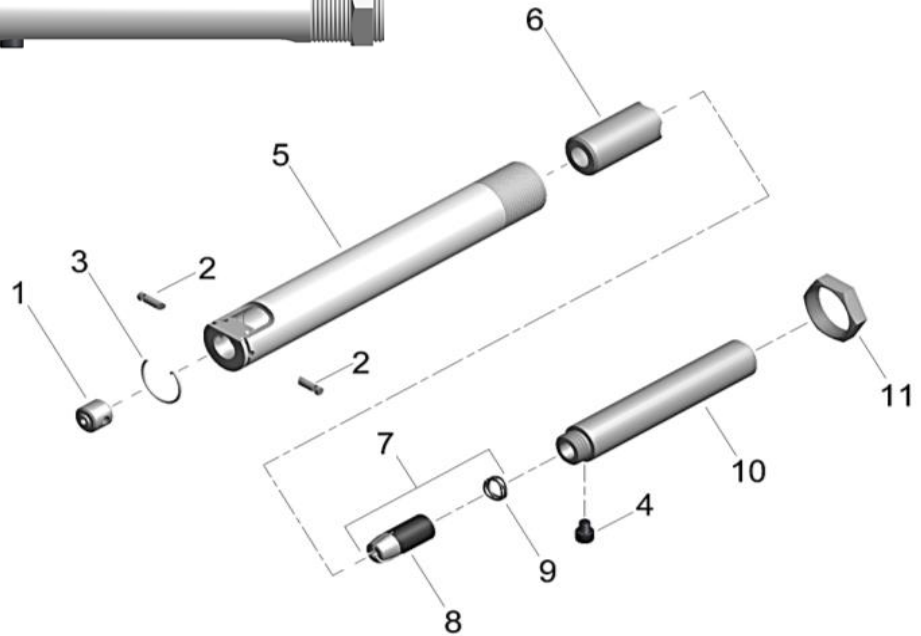

*GB715 & GB51 for 3/16" Ø Self-Plugging aluminum maximum.
 ** GB50 for 3/32" & 1/8" Ø only.
 ***GB752 requires 730715 adapter.

7/07 REV. 9/15

Covered under Patent No. 5,029,881

GAGE BILT
 MADE in the USA

GAGE BILT Inc.

44766 Centre Court +1 (586) 226-1500
 Clinton Twp. MI 48038 USA +1 (586) 226-1505 Fax
 e-mail: solutions@gagebilt.com / www.gagebilt.com

Type: Single Action Non Self-Releasing		Fasteners: NAS1398A/1399A NAS1738A/1739A RV1000/1100 & 1200	Recommended Tool: *GB715			
3/32", 1/8", 5/32" & 3/16" Ø			Alternate Tools: *GB51, **GB50 & ***GB752			

Ref. No.	Qty.	Description	3A-715B-43	4A-715B-43	5A-715B-43	6A-715B-43
1	1	Anvil Insert	10303	10304	10305	10306
2	2	Ratchet Pin	15504	15503	15501	15501
3	1	Ratchet Pin Spring	50302	50302	50302	50302
4	1	Screw	70303	70303	70303	70303
5	1	Anvil Holder	10301	10301	10301	10301
6	1	Collet	20301	20301	20301	20301
7	1	Jaw Assembly (Inc. 8 & 9)	30314-A1	-----	-----	-----
8	1	Super Grip Jaw Assy	30314-S5	30418-S	30529-S	30633-S4
9	1	Wave Spring	A-1513	-----	-----	-----
10	1	Drawbolt	70301	70301	70301	70301
11	1	Locknut	70411	70411	70411	70411