

NOSE ASSEMBLY DATA SHEET

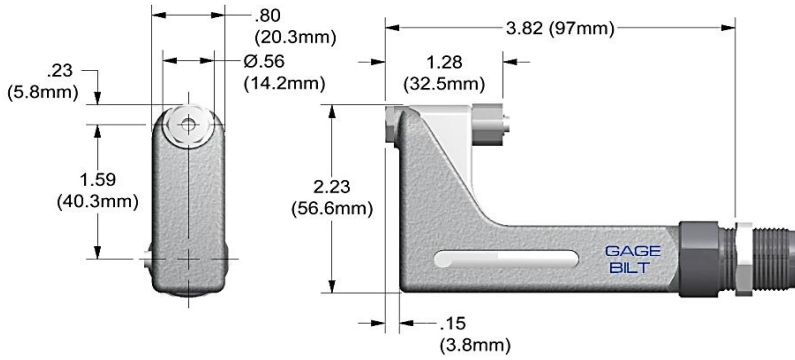

Attachment:
 Screw collet adapter (9) onto piston of tool.
 Screw anvil adapter (10) into nose fitting of tool. Screw nose assembly onto tool until it stops then back off until nose is in desired position. (Warning: do not back off nose assembly more than one complete turn).
 Lock jam nut (70104) against face of adapter.

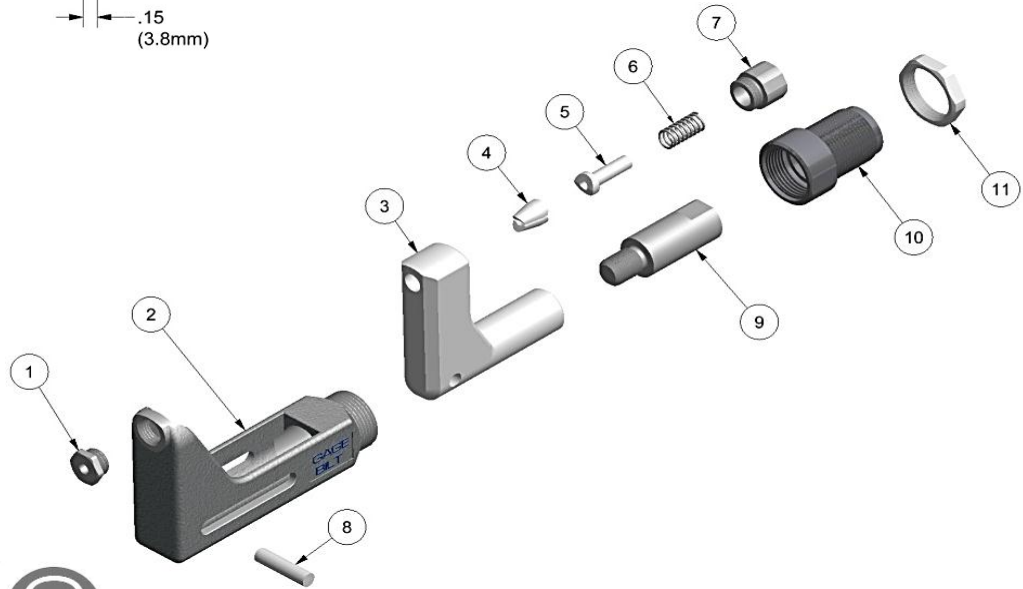

3/11 Rev. 3/14

GAGE BILT
 MADE IN U.S.A.

GAGE BILT Inc.

44766 Centre Court (586) 226-1500
 Clinton Twp. MI 48038 (586) 226-1505 Fax
 e-mail:solutions@gagebilt.com / www.gagebilt.com

Type:	Fasteners:	Recommended Tool: GB704
Non Self-Releasing 1/8", 5/32" & 3/16" Ø	CHERRYMAX®, CHERRYMAX® 'AB', MBC® LOCK CREATOR BACR15FR/FP, BACR15GF/GK, NAS1900 S & U SERIES BLIND RIVET WITH DRIVE WASHER	

Ref. No.	Qty.	Description	456MAX-704-400S
1	1	Nose Tip	13452
2	1	Anvil Holder	13368
3	1	Collet	20915
4	1	Jaw Set	30617
5	1	Follower	40506
6	1	Spring	A-1503
7	1	Cap	60429
8	1	Pin	70468
9	1	Collet Adapter	70473
10	1	Anvil Adapter	70472
11	1	Jam Nut	70104