

# NOSE ASSEMBLY DATA SHEET

Use Hex-Key in rear of piston  
For nose assembly attachment

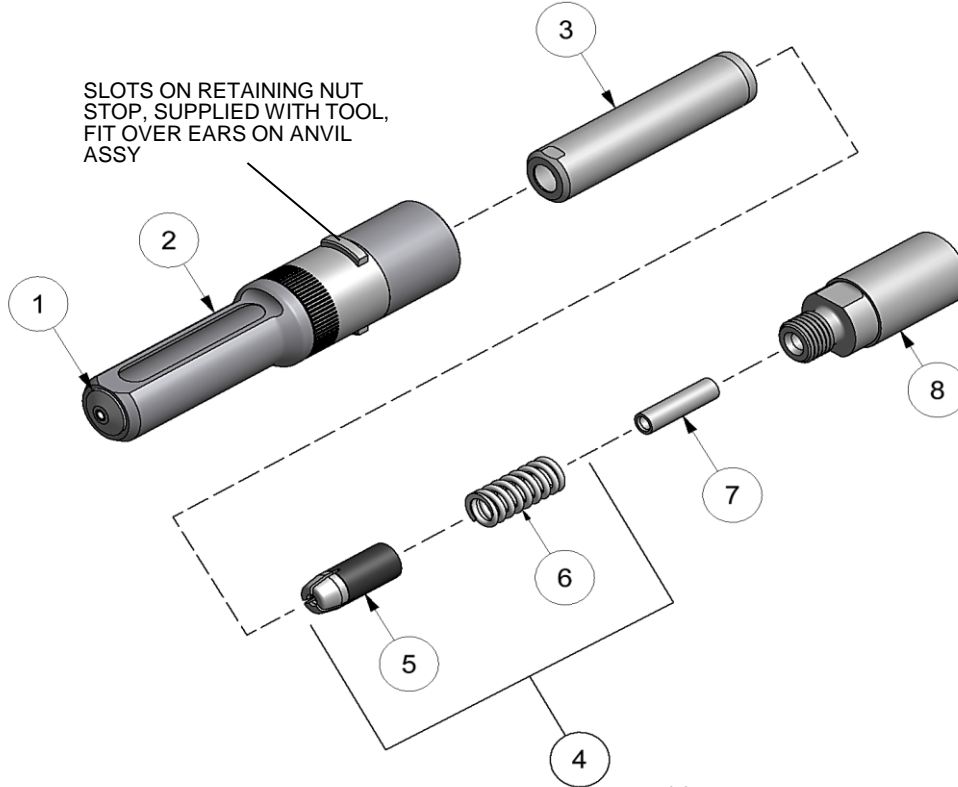
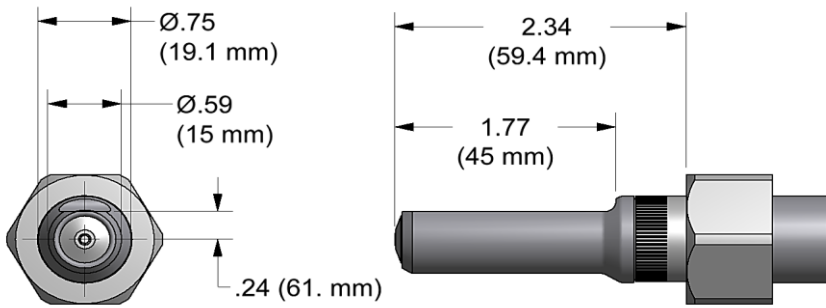

\*\*Anvil Assembly includes 35208 retainer.

REV 12/15

## GAGE BILT

### GAGE BILT Inc.

44766 Centre Court (586) 226-1500  
Clinton Twp., MI 48038 (586) 226-1505 Fax  
e-mail:solutions@gagebilt.com / www.gagebilt.com

| Type:<br>Non Self-Releasing |      | Fastener:<br>NAS1398A/1399A<br>NAS1738A/1739A<br>RV1000/1100 & 1200<br>*1/8 Ø AF5075 / AF5076 / S149A020 | Recommended Tool:<br>GB752                   |
|-----------------------------|------|--|--|
| *3/32" Ø                    |      |  | Alternate Tools:<br>GB751, GB722 & GB2480(A) |
| Ref. No.                    | Qty. | Description  | 3A-352B-25                                   |
| 1                           | 1    | Anvil-Driving  | 13001  |
| 2                           | 1    | Anvil & Holder Assy (Inc. #1)  | 19943  |
| 3                           | 1    | Collet   | 20502  |
| 4                           | 1    | Jaw Assy (inc. 5 & 6)  | 30314-A3                                     |
| 5                           | 1    | Super Grip Jaw Assy  | 30314-CS                                     |
| 6                           | 1    | Spring   | 50517  |
| 7                           | 1    | Spacer   | 60302  |
| 8                           | 1    | Adapter  | 70501  |