

NOSE ASSEMBLY DATA SHEET

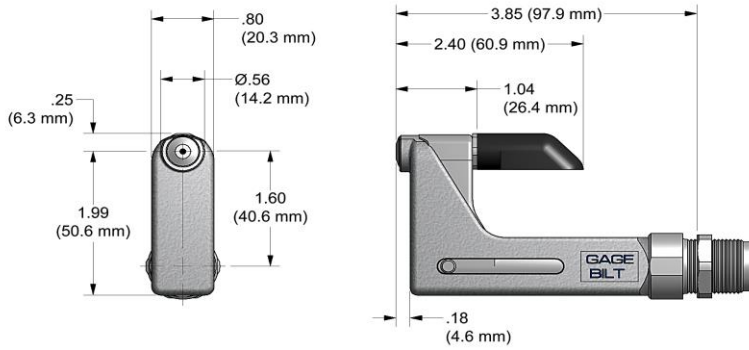

CAUTION:
Do not operate if pintail deflector is removed. Pintail may eject forcibly. SEVERE PERSONAL INJURY MAY RESULT.

Attachment:
Screw adapter-collet (9) onto piston of tool. Screw anvil adapter (6) into nose fitting of tool. Screw nose assembly onto tool until it stops then back off until nose is in desired position. (Warning: do not back off nose assembly more than one complete turn). Lock locknut (70104) against face of adapter.

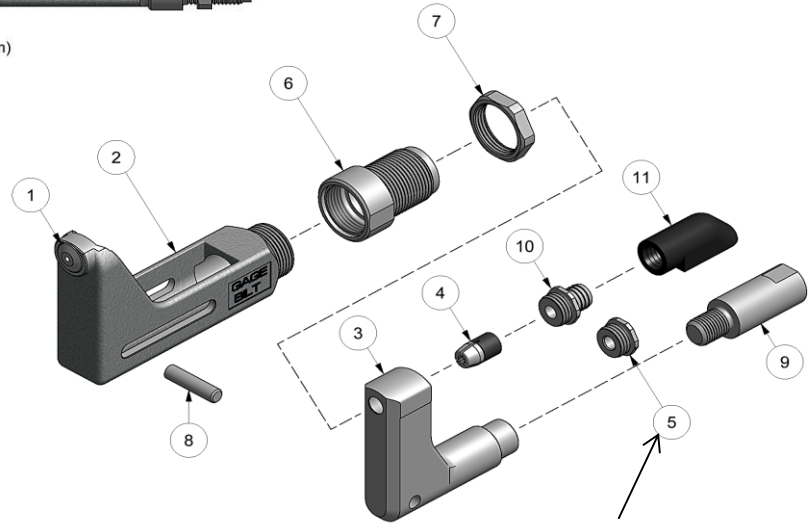

Cap (5) is used for closed access applications only or when clearance is an issue.

WARNING:
KEEP FINGERS AND HANDS AWAY FROM NOSE ASSEMBLY DURING OPERATION TO PREVENT SEVERE PERSONAL INJURY.



6/16

GAGE BILT
MADE IN U.S.A.

GAGE BILT Inc.
44766 Centre Court +1 (586) 226-1500
Clinton Twp., MI 48038 +1 (586) 226-1505 Fax
e-mail:solutions@gagebilt.com / www.gagebilt.com

Type:		Fasteners:		Recommended Tool: GB704
Non Self-Releasing 3/32" Ø		MS20600, CHERRY® 9000 HUCK® PT, SP & MS RV200 & RV500		
Ref. No.	Qty.	Description	3C-704-400S	
1	1	Anvil Insert	13002	
2	1	Anvil & Holder Assy (Incl. #1)	13373	
3	1	Collet	20914	
4	1	Suover Grip Jaw Assy	30314-S2	
5	1	Cap	60428	
6	1	Anvil Adapter	70472	
7	1	Lock Nut	70104	
8	1	Pin	70468	
9	1	Adapter-Collet	70473	
10	1	Barbed Retainer	60440	
11	1	Deflector	61107	