

GB740

SERIES INSTALLATION TOOL

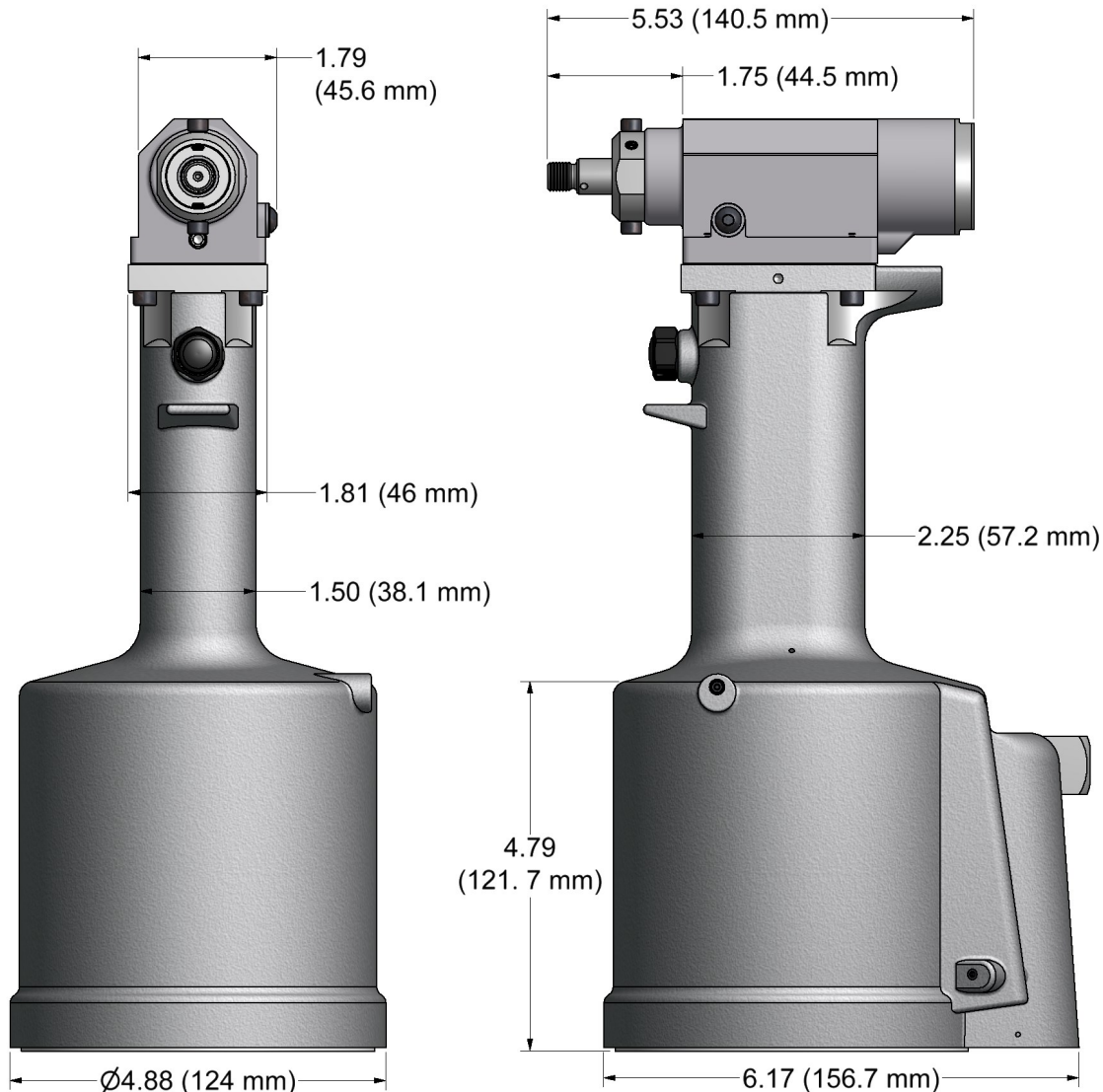

DESCRIPTION

The GB740 is a heavy-duty, high speed production tool specifically designed for a wide range of blind rivets. It weighs only 6.5 pounds and can be operated in any position with one hand. With the use of a pneumatic-hydraulic system, it develops a pull load of 2,400 pounds at 90 psi (6.2 bar) and has a 1.330" (33.78mm) stroke.

The GB740 riveter operates on 90 to 100 psi. (6.2-6.9 bar) of air pressure, with 90 psi (6.2 bar) providing the maximum efficiency. At 90 psi (6.2 bar), the GB740 does not exceed 85 dB(A) and consumes 6 cfm at 20 cycles per minute.

The air inlet is provided with 1/4-18 female pipe thread for accepting the user's air hose fitting.

NOSE ASSEMBLIES ARE NOT FURNISHED WITH THIS RIVETER AND MUST BE ORDERED SEPARATELY.

GAGE BILT
 **MADE in USA**

44766 Centre Court Clinton Twp. MI 48038 USA
Ph: +1 (586) 226-1500 Fax: +1 (586) 226-1505
solutions@gagebilt.com / www.gagebilt.com



GB740-NOSE ASSEMBLY SELECTION CHART & ACCESSORIES



ACCESSORIES (SOLD SEPARATELY)

NOSE ASSEMBLIES (SOLD SEPARATELY)

Air Bleeder Assy
#704153 (Equivalent to #700A77)



Catcher Bag
#756610



Catcher Bag
#704214 (Equivalent to #670A20)



740715 Adapter
Adapts various nose assy's to GB740 tool (See chart).



Riveter Kits Available
Contact Gage Bilt to create your own custom kit.



STRAIGHT

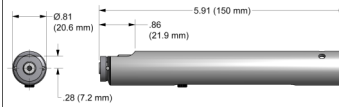

RIGHT ANGLE

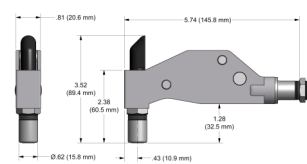

OFFSET

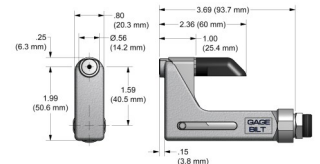

FASTENER	DIA.	STRAIGHT	RIGHT ANGLE ^{1,2}	OFFSET ¹
MS20600 SERIES	1/8	4C-740B-52	4C-715A-54RA	4C-715-40OS
MS/9SP/PT	5/32	5C-740B-52	5C-715A-54RA	5C-715-40OS
NUT PLATE	3/16	6C-740B-52	6C-715A-54RA	6C-715-40OS
BACR15CC/CF/DA/DR	1/4	8C-740B-52		
OLYMPIC LOK®	1/8	4A-740B-52	4A-715A-54RA	4A-715-40OS
BULB LOK®	5/32	5A-740B-52	5A-715A-54RA	5A-715-40OS
NAS1398A, NAS1399A	3/16	6A-740B-52	6A-715A-54RA	6A-715-40OS
NAS1738A, NAS1739A	1/4	8A-740B-52		
CHERRYLOCK®	1/8	4C-640-64		4C-640A-50
NAS1398, NAS 1399 ₃	5/32	5C-640-64		5C-640A-50
NAS1738, NAS 1739 ₄	3/16	6C-640-64		6C-640A-50
	1/4	8C-640-64		8C-640A-50
GROUND STUD				
M83454	8/32	GS8-715B-43 ₁	GS8-715-54RA	GS8-715-40OS
BACSS3B1EA1/2				

CHERRYLOCK® IS A REGISTERED TRADEMARK OF CHERRY AEROSPACE. OLYMPIC LOK & BULB LOK® ARE REGISTERED TRADEMARKS OF ALLFAST FASTENING SYSTEMS INC.

GAGE BILT CERTIFIES THE GB740 WILL INSTALL THE ABOVE FASTENERS

- 1) REQUIRES 740715 ADAPTER.
 - 2) RIGHT ANGLE NOSE ASSEMBLIES MAY REQUIRE MORE THAN 1 PULL.
 - 3) 1/4 DIAMETER ALUMINUM & MONEL® ONLY.
 - 4) THRU 3/16 DIAMETER ONLY.
- *ALL COUNTERSUNK 'C' NOSE ASSEMBLIES MAY BE USED TO INSTALL BOTH UNIVERSAL AND COUNTERSUNK HEAD RIVETS.

NOTE: THE LAST 2 DIGITS OF THE NOSE ASSEMBLY REPRESENTS THE LENGTH THE NOSE EXTENDS FROM THE TOOL. I.E. -52 = 5.2 INCHES

11/16

Grip gage for CHERRYMAX® and CHERRY-LOCK® rivets # 269G3 (Similar to #269C3)



Grip gage for NAS LOCKBOLTS and BLIND fasteners #GB105093 (Equivalent to #105093)



Riveter Kits Available

Contact Gage Bilt to create your own custom kit.

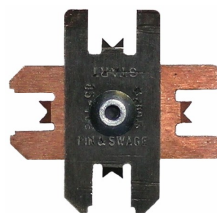

Gage Bilt also supplies pin & collar swage inspection gages to certify correct swage installation

