

NOSE ASSEMBLY DATA SHEET

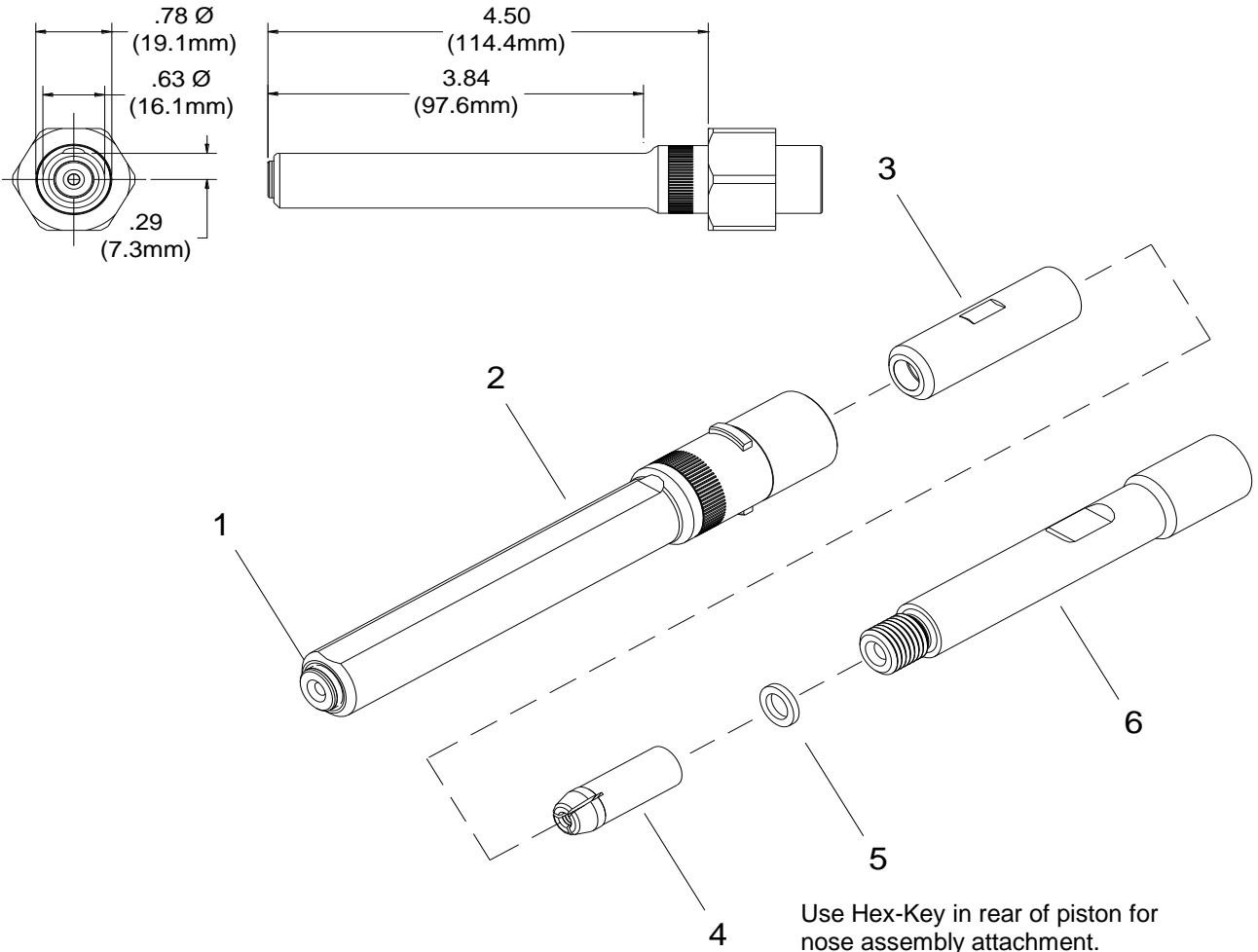

*Anvil Assembly consists of #1 and 35208 retainer.

1/12 REV 4/14



GAGE BILT
MADE IN U.S.A.

GAGE BILT Inc.
44766 Centre Court (586) 226-1500
Clinton Twp., MI 48038 (586) 226-1505 Fax
e-mail:solutions@gagebilt.com / www.gagebilt.com

Type:		Fastener:	Recommended Tool: GB752	
Non Self-Releasing 1/8 & 5/32 Ø		NAS1398A/1399A RV1000/1100 & 1200	Alternate Tools: GB751 & GB2480	
Ref. No.	Qty.	Description	4A-752C-45	5A-752C-45
1	1	Anvil-Driving	10427	10560
2	1	Anvil & Holder Assy.	17763	17764
2a	1	(Includes #1)		
3	1	Collet	20727	20727
4	1	Super-Grip Jaw Assembly	30425-CS	30545-CS
5	1	Spacer	70572	70572
6	1	Collet Extension	70551	70551