

NOSE ASSEMBLY DATA SHEET

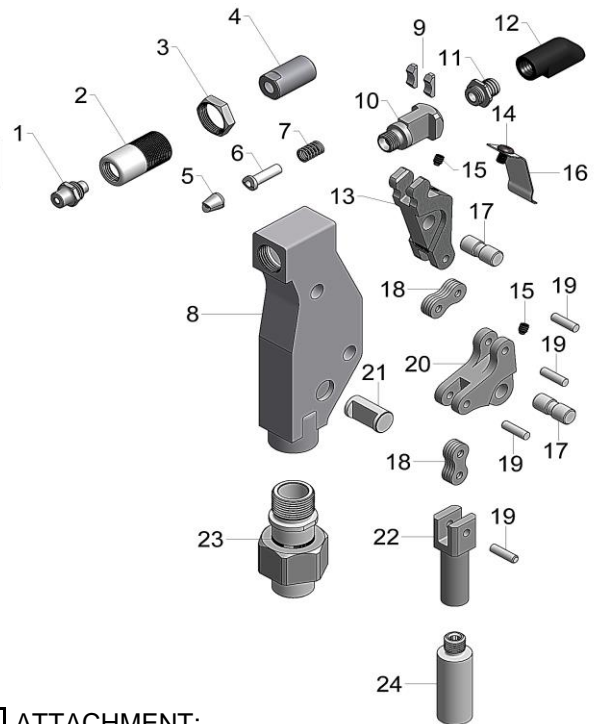
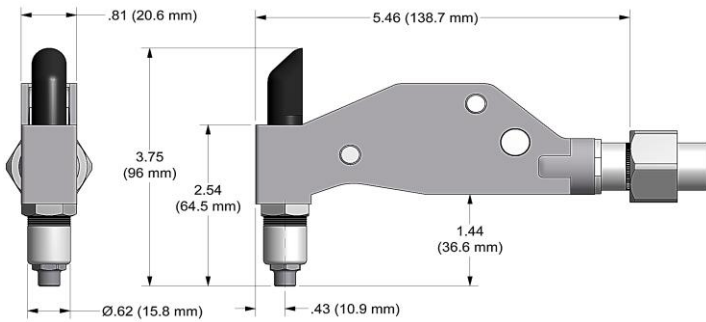

CAUTION!

Do not operate if pintail deflector is removed. Pintail may eject forcibly. SEVERE PERSONAL INJURY MAY RESULT.

*GB722 USE 722142 STROKE LIMITER.

**GB752 USE 752142 STROKE LIMITER.

***MOST FASTENERS REQUIRE MORE THAN ONE PULL



9/10 Rev. 11/16

GAGE BILT MADE in USA

44766 Centre Court Clinton Twp. MI 48038 USA
Ph: +1 (586) 226-1500 Fax: +1 (586) 226-1505
solutions@gagebilt.com / www.gagebilt.com

Type:	Fasteners:	Recommended Tool: GB751
Single Action 3/16" Ø	POP® OPEN END NAIL RIVET	Alternate Tool: *GB722 & **GB752

Ref. No.	Qty.	Description	6N-751C-54RA
1	1	Anvil-Driving	10204
2	1	Anvil Holder	10125
3	1	Jam Nut	70411
4	1	Collet	20327
5	1	Jaw Set	30617-1
6	1	Follower	40304-2
7	1	Spring	50427
8	1	Frame	75310
9	2	Shoe Bearing	75311
10	1	Drawbolt Collet	70486-1
11	1	Barbed Retainer	70575
12	1	Deflector	61107
13	1	Lever	75313
14	1	Button Head Cap Screw	402471
15	2	Set Screw	75315
16	1	Guard	75316
17	2	Pivot Pin	75317
18	8	Link	75318
19	4	Link Pin	75319
20	1	Bellcrank	75320
21	1	Guide Pin	75321
22	1	Drawbolt	75322
23	1	Adapter Assy	70459
24	1	Extension-Collet	70463

ATTACHMENT:

Disconnect air supply from tool. Hold back of drawbolt-collet (10) down with thumb. Thread anvil holder (2) into frame (8) until it bottoms out on collet (4). Loosen approximately 1/4 turn and tighten jam nut (3) securely to frame (8). Engage one or two threads of collet extension (24) onto piston assy located on tool, then insert adapter assy (23) into end of head cylinder assy located on tool and turn clockwise until snug. Rotate nose assembly to desired position and tighten jam nut (3) securely. Reconnect air supply to tool.

DISASSEMBLY:

Loosen jam nut (3) and remove anvil holder (2). Unscrew collet (4) which contains jaw set (5) from drawbolt-collet (10).

Remove button head cap screw (14) and guard (16). Remove two set screws (15) and push out two pivot pins (17) to permit removal of linkage. Shoe bearings (9) and drawbolt-collet (10) will disengage from lever (13).

Remove four link pins (19) to disassemble lever (13), links (18), bellcrank (20) and drawbolt (22).

Remove guide pin (21) from frame (8). Adapter Assy (23) is secured to frame with Loctite® and need not be removed unless damaged.

REASSEMBLY:

Reverse the procedure. Linkage, consisting of lever (13), links (18), bellcrank (20) and drawbolt (22) should be assembled as a subassembly before inserting lever (13) into shoe bearings (9) and drawbolt-collet (10). MAKE SURE NOTCHES ON DRAWBOLT-COLLET (10) ARE POINTING TOWARDS LEVER (13). This complete subassembly may then be inserted into frame (8) and retained by guide pin (21) and pivot pins (17).