

NOSE ASSEMBLY DATA SHEET

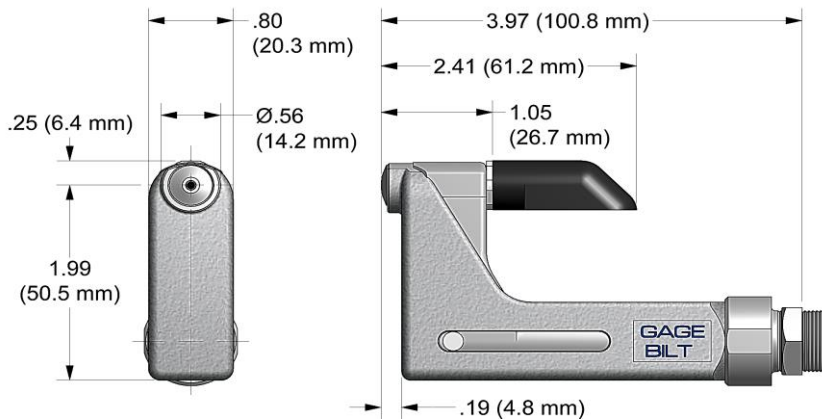

CAUTION:

Do not operate if pintail deflector is removed. Pintail may eject forcibly. SEVERE PERSONAL INJURY MAY RESULT.

Attachment

Screw nose assembly onto tool until it stops then back off until nose is in desired position. (Warning: do not back off nose assembly more than one complete turn). Lock jam nut (70411) against adapter (70341)

WARNING:
KEEP FINGERS AND HANDS AWAY FROM NOSE ASSEMBLY DURING OPERATION TO PREVENT SEVERE PERSONAL INJURY.

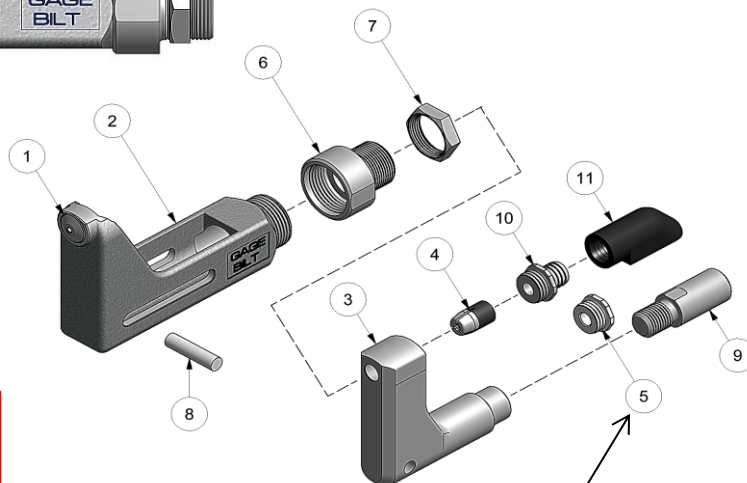

Cap (5) is used for closed access applications only or when clearance is an issue.



4/06 Rev. 4/15

*GB715 will pull 5/32 & 3/16 fasteners in aluminum only.

GAGE BILT

MADE IN U.S.A.

GAGE BILT Inc.

44766 Centre Court (586) 226-1500
Clinton Twp. MI 48038 (586) 226-1505 Fax
e-mail:solutions@gagebilt.com / www.gagebilt.com

Type:		Fasteners:		Recommended Tool:		
Non Self-Releasing 3/32", 1/8", 5/32" & 3/16" Ø		NAS1919A NAS1921A "A" CODE		GB715		
Ref. No.	Qty.	Description	3A-715-400S	4A-715-400S	*5A-715-400S	*6A-715-400S
1	1	Anvil Insert	13001	10488	15001	16028
2	1	Anvil & Holder Assy (Inc. #1)	12216	12217	12218	12219
3	1	Collet	20914	20911	20911	20911
4	1	Super-Grip Jaw Assy	30314-S7	30425-S2	30545-S4	30656-S3
5	1	Cap	60428	60428	60428	60428
6	1	Anvil Adapter	70341	70341	70341	70341
7	1	Jam Nut	70411	70411	70411	70411
8	1	Pin	70468	70468	70468	70468
9	1	Collet Adapter	70340	70340	70340	70340
10	1	Barbed Retainer	60440	60440	60440	60440
11	1	Deflector	61107	61107	61107	61107