

# NOSE ASSEMBLY DATA SHEET

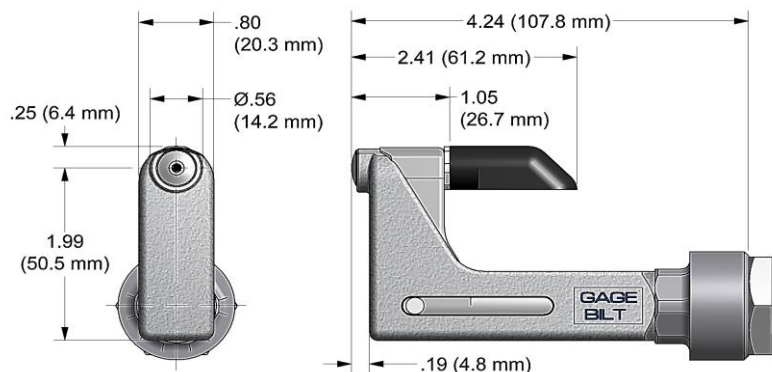

**CAUTION:**  
Do not operate if pintail deflector is removed. Pintail may eject forcibly. SEVERE PERSONAL INJURY MAY RESULT.

## Attachment

Screw nose assembly onto tool until it stops then back off until nose is in desired position. (Warning: do not back off nose assembly more than one complete turn). Lock jam nut (70336) against adapter (70332)

**WARNING:**  
KEEP FINGERS AND HANDS AWAY FROM NOSE ASSEMBLY DURING OPERATION TO PREVENT SEVERE PERSONAL INJURY.

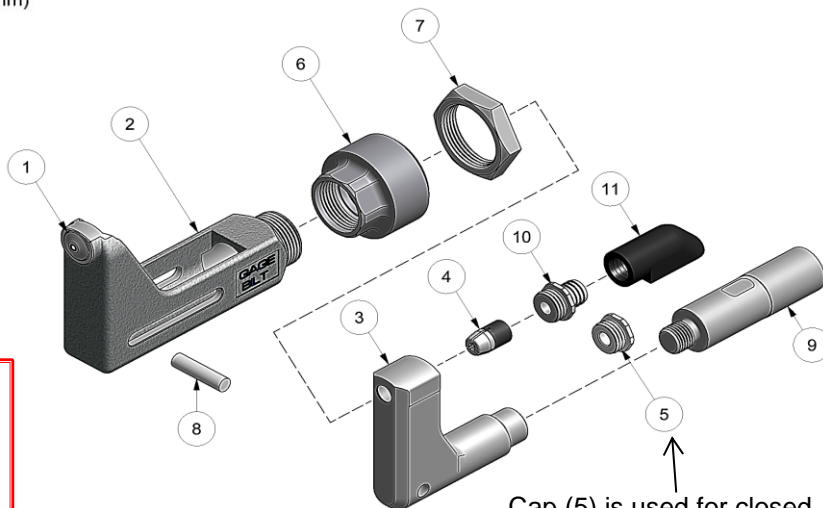

Cap (5) is used for closed access applications only or when clearance is an issue.



9/06 Rev. 12/15

\*\*USE ADAPTER 745751 & DO NOT USE # (7) JAM NUT 70336.

**GAGE BILT**  
MADE IN U.S.A.

**GAGE BILT Inc.**

44766 Centre Court (586) 226-1500  
Clinton Twp. MI 48038 (586) 226-1505 Fax  
e-mail:solutions@gagebilt.com / www.gagebilt.com

Type:		Fasteners:	Recommended Tool:
Non Self-Releasing *3/32" Ø		NAS1398A/1399A RV 1000/1100 & 1200 *1/8 Ø AF5075 / AF5076 / S149A020	GB751
			Alternate Tools: GB722 & **GB745
Ref. No.	Qty.	Description	3A-752A-43OS
1	1	Anvil Insert	13001
2	1	Anvil & Holder Assy (Inc. #1)	12216
3	1	Collet	20915
4	1	Super-Grip Jaw Assy	30314-S7
5	1	Cap	60428
6	1	Anvil Adapter	70331
7	1	Jam Nut	70336
8	1	Pin	70468
9	1	Collet Adapter	70332
10	1	Barbed Retainer	60440
11	1	Deflector	61107