

NOSE ASSEMBLY DATA SHEET

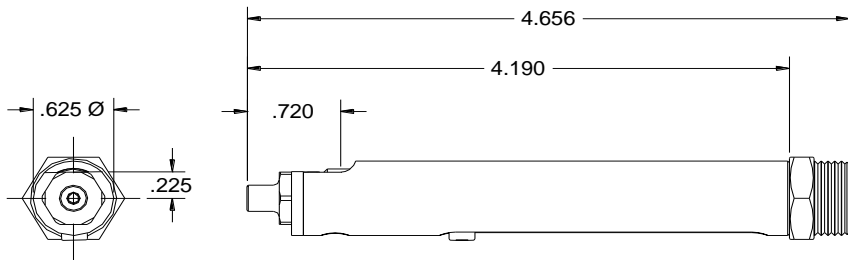

1. Place GB51 on table with collet adapter pointing up.
2. Use palm of hand to push drawbolt and anvil holder on tool and screw down until it stops. (use a rag or padding in palm of hand. Spring in collet requires some force to collapse allowing threads to engage nose fitting).
3. Insert a rivet into front of nose assembly making sure jaws release pintail. If jaws don't release pintail repeat these steps and ensure that collet is full forward in the nose assembly.

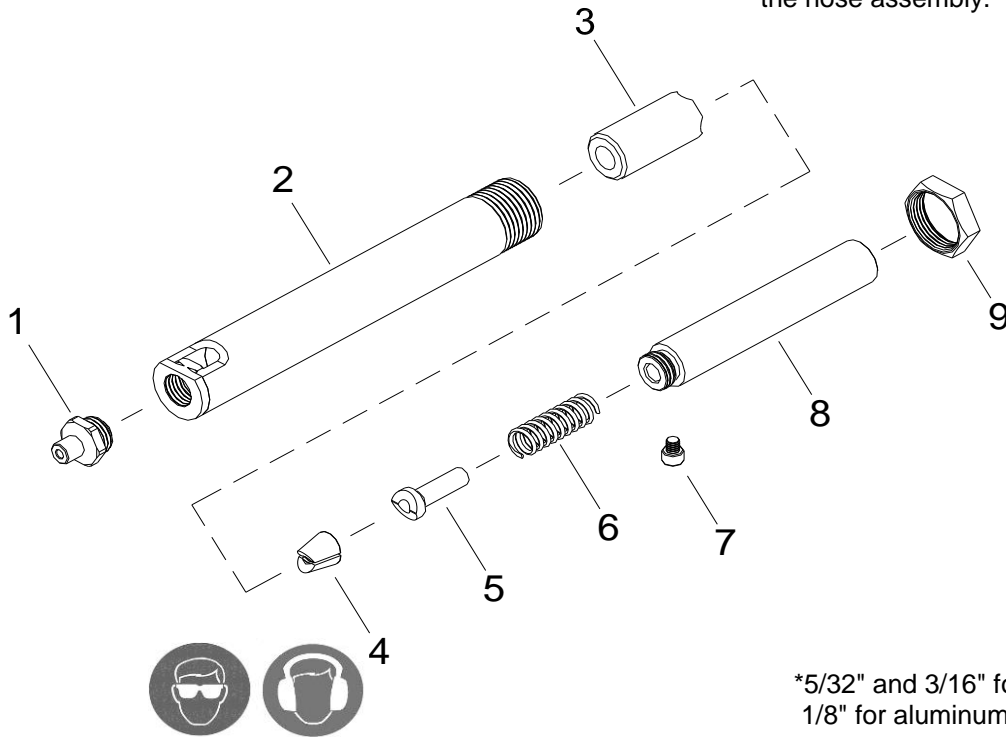

*5/32" and 3/16" for aluminum only.
1/8" for aluminum and steel only.

Rev. 3/16

GAGE BILT Inc.

44766 Centre Court (586) 226-1500
Clinton Twp., MI 48038 (586) 226-1505 Fax
e-mail:solutions@gagebilt.com / www.gagebilt.com

Type: Self-Releasing		Fastener: N, Q & E POP®, CLOSED END AVEX® & COMMERCIAL RIVETS	Recommended Tool: GB51			
3/32", *1/8", *5/32" and *3/16" Ø			Alternate Tools: GB715			
Ref. No.	Qty.	Description	3N- 715E-43	4N- 715E-43	5N- 715E-43	6N- 715E-43
1	1	Nose Tip	10247	10202	10203	10204
2	1	Anvil Holder	17722-3	17722-3	17722-3	17722-3
3	1	Collet	20301	20301	20301	20301-1
4	1	Chuck Jaw	30311	30311	30311	30617-1
5	1	Follower	40506	40506	40506	40506
6	1	Spring	50420	50420	50420	50420
7	1	Screw	70303	70303	70303	70303
8	1	Drawbolt	70301	70301	70301	70301
9	1	Nut	70411	70411	70411	70411