



# Hi-Rel DC/DC CONVERTER MGDM-25 : 25W POWER

Hi-Rel  
Grade ■■

Single, Bi & Triple Outputs  
Metallic Case - 1 500 VDC Isolation



4

- 28Vdc input compliant with MIL-STD-704 D/E
- Nominal power up to 25 W without derating
- Wide temperature range : -40°C/+105°C case
- High efficiency up to 87%
- Soft start
- Galvanic isolation 1.500 VDC
- Integrated LC EMI filter
- Permanent short circuit protection
- No optocoupler for high reliability
- RoHS or Leaded process option

## 1-General

The MGDM-25 series is a full family of high performance DC/DC power modules designed for aerospace, military and high-end industrial applications. These modules use a frequency fixed switching technic at 250KHz providing excellent reliability, low noise characteristics and high power density. Standard models are available with nominal input voltage of 28 volts in a voltage range of 9-36, 16-40 volts. The series include single, bi and triple output voltage choices of 3,3, 5, 12, 15 volts.

No external heatsink is required for the MGDM-25 series to supply 25W output power over the case temperature range of -40°C up to 105°C. All the modules are designed with LC network filters to minimize reflected input current ripple and output voltage ripple.

The modules include a soft-start, a permanent

short circuit protection and an output overvoltage protection to ensure efficient module protections.

The soft-start allows current limitation and eliminates inrush current during start-up. The short circuit protection completely protects the modules against short-circuits of any duration by a shut-down and restores to normal when the overload is removed.

The design has been carried out with surface mount components and is manufactured in a fully automated process to guarantee high quality. Each module is tested and burned in with a GAIA converter automated test equipment. The modules are potted with a bi-component thermal conductive compound and packaged in a metallic case to ensure the module's integrity under high environmental conditions.

## 2-Product Selection

Single output model : MGDS - 25 -  -  /  -   
 Bi output model : MGDB - 25 -  -  /  -   
 Triple output model : MGDT - 25 -  -  /  -

| Input Voltage Range |                 |
|---------------------|-----------------|
| Permanent           | Transient       |
| H : 9-36 VDC        | 40 VDC/100 ms * |
| J : 16-40 VDC       | 50 VDC/100 ms * |
| * Consult factory   |                 |

### Options :

/M : On/Off function  
 /T : option for -55°C start up operating temperature  
 /S : option for screening and serialization

| Output                     |
|----------------------------|
| B : 3,3 VDC                |
| C : 5 VDC or +/-5VDC       |
| E : 12 VDC or +/-12VDC     |
| F : 15 VDC or +/-15VDC     |
| BE : 3,3 VDC and +/-12 VDC |
| BF : 3,3 VDC and +/-15 VDC |
| CE : 5 VDC and +/-12 VDC   |
| CF : 5 VDC and +/-15 VDC   |

### Suffix :

nothing : RoHS process  
 -L : leaded process (available in N. America)

## 2- Product Selection (continued)

| Input range | Output           | Current           | Reference    | Options    | Suffix |
|-------------|------------------|-------------------|--------------|------------|--------|
| 9-36 VDC    | 3,3 VDC          | 6 A               | MGDS-25-H-B  | /M, /T, /S | -, -L  |
| 9-36 VDC    | 5 VDC            | 5 A               | MGDS-25-H-C  | /M, /T, /S | -, -L  |
| 9-36 VDC    | 12 VDC           | 2 A               | MGDS-25-H-E  | /M, /T, /S | -, -L  |
| 9-36 VDC    | 15 VDC           | 1,65 A            | MGDS-25-H-F  | /M, /T, /S | -, -L  |
| 9-36 VDC    | +/-5 VDC         | +/-2,5 A          | MGDB-25-H-C  | /M, /T, /S | -, -L  |
| 9-36 VDC    | +/- 12 VDC       | +/- 1 A           | MGDB-25-H-E  | /M, /T, /S | -, -L  |
| 9-36 VDC    | +/- 15 VDC       | +/- 0,825 A       | MGDB-25-H-F  | /M, /T, /S | -, -L  |
| 9-36 VDC    | 5 & +/- 11,5 VDC | 2,5 A & +/- 0,5 A | MGDT-25-H-CE | /M, /T, /S | -, -L  |
| 9-36 VDC    | 5 & +/- 14,6 VDC | 2,5 A & +/- 0,4 A | MGDT-25-H-CF | /M, /T, /S | -, -L  |
| 16-40 VDC   | 3,3 VDC          | 6 A               | MGDS-25-J-B  | /M, /T, /S | -, -L  |
| 16-40 VDC   | 5 VDC            | 5 A               | MGDS-25-J-C  | /M, /T, /S | -, -L  |
| 16-40 VDC   | 12 VDC           | 2 A               | MGDS-25-J-E  | /M, /T, /S | -, -L  |
| 16-40 VDC   | 15 VDC           | 1,65 A            | MGDS-25-J-F  | /M, /T, /S | -, -L  |
| 16-40 VDC   | +/-5 VDC         | +/-2,5 A          | MGDB-25-J-C  | /M, /T, /S | -, -L  |
| 16-40 VDC   | +/- 12 VDC       | +/- 1 A           | MGDB-25-J-E  | /M, /T, /S | -, -L  |
| 16-40 VDC   | +/- 15 VDC       | +/- 0,825 A       | MGDB-25-J-F  | /M, /T, /S | -, -L  |
| 16-40 VDC   | 5 & +/- 11,5 VDC | 2,5 A & +/- 0,5 A | MGDT-25-J-CE | /M, /T, /S | -, -L  |
| 16-40 VDC   | 5 & +/- 14,6 VDC | 2,5 A & +/- 0,4 A | MGDT-25-J-CF | /M, /T, /S | -, -L  |

4

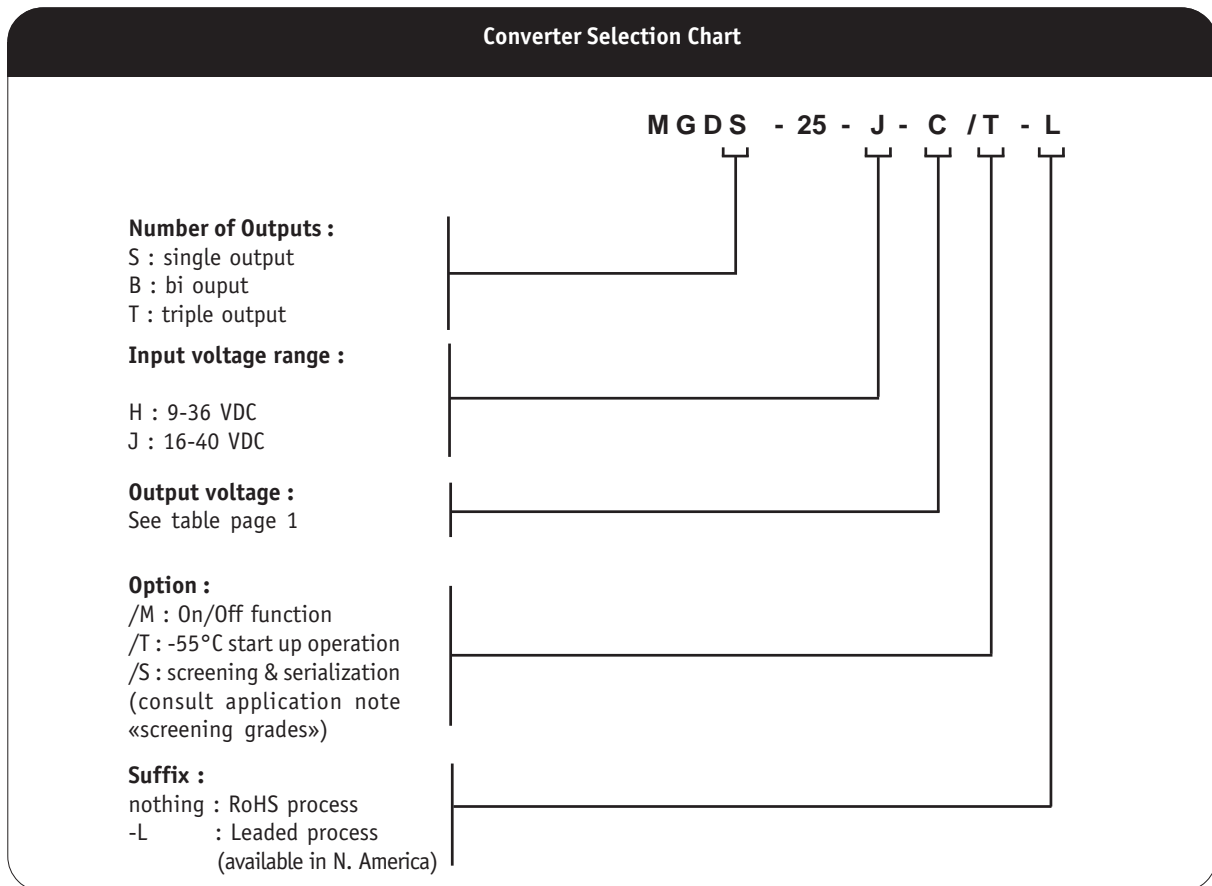

### 3- Electrical Specifications

Data are valid at +25°C, unless otherwise specified.

| Parameter                                     | Conditions   | Limit or typical   | Units                        | Single Output MGDS-25 |         |       |
|---|--|--------------------|------------------------------|-----------------------|---------|-------|
|   |  |                    |                              | 25 - H                | 25 - J  |       |
| <b>Input</b>                                  |  |                    |                              |                       |         |       |
| Nominal input voltage                         | Full temperature range   | Nominal            | VDC                          | 20                    | 28      |       |
| Permanent input voltage range (Ui)            | Full temperature range   | Min. - Max.        | VDC                          | 9-36                  | 16-40   |       |
| Extended permanent input voltage              | Full load (Consult factory)                                      | Min. - Max.        | VDC                          | /                     | 16-45   |       |
| Transient input voltage                       | Full load (Consult factory)                                      | Maximum            | VDC/S                        | 40/0,1                | 50/0,1  |       |
| Start up input voltage                        | Full load  | Minimum            | VDC                          | 8,5                   | 15      |       |
| Start up time                                 | Ui nominal within 3ms<br>Nominal output<br>Full load : resistive | Maximum            | ms                           | 30                    | 30      |       |
| Reflected ripple current (Average)            | Ui nominal, full load at switching freq. BW = 20MHz              | Typical            | mApp                         | 300                   | 300     |       |
| Input current in short circuit mode (Average) | Ui nominal<br>Short-circuit                                      | Typical            | mA                           | 40                    | 40      |       |
| No load input current                         | Ui nominal<br>No load  | Maximum            | mA                           | 60                    | 60      |       |
| <b>Output</b>                                 |  |                    |                              |                       |         |       |
| Output voltage                                | Full temperature range<br>Ui min. to max.<br>75% load            | Nominal            | VDC                          | 3,3                   | 3,3     |       |
|   |  | Nominal            | VDC                          | 5                     | 5       |       |
|   |  | Nominal            | VDC                          | 12                    | 12      |       |
|   |  | Nominal            | VDC                          | 15                    | 15      |       |
| Set Point accuracy                            | Ambient temperature : +25°C<br>Ui nominal, 75% load              | Maximum            | %                            | +/- 2                 | +/- 2   |       |
| Output power                                  | Full temperature range<br>Ui min. to max.                        | Maximum            | W                            | 25                    | 25      |       |
| Output current *                              | Full temperature range<br>Ui min. to max.                        | 3,3V output        | Maximum                      | A                     | 6       | 6     |
|   |  | 5V output          | Maximum                      | A                     | 5       | 5     |
|   |  | 12V output         | Maximum                      | A                     | 2       | 2     |
|   |  | 15V output         | Maximum                      | A                     | 1,65    | 1,65  |
| Ripple output voltage **                      | Ui nominal<br>Full load<br>BW = 20MHz                            | 3,3V and 5V output | Maximum                      | mVpp                  | 50      | 50    |
|   |  | 12V output         | Maximum                      | mVpp                  | 100     | 100   |
|   |  | 15V output         | Maximum                      | mVpp                  | 150     | 150   |
|   |  | Line regulation    | Ui min. to max.<br>Full load | Typical               | %       | +/- 1 |
| Load regulation ***                           | Ui nominal<br>25% to full load                                   | Typical            | %                            | +/- 2,5               | +/- 2,5 |       |
| Efficiency                                    | Ui nominal<br>Full load  | Typical            | %                            | See on page 6         |         |       |
| Maximum admissible Capacitive load            | Ui nominal<br>Full load<br>Per output                            | 3,3V and 5V output | Maximum                      | µF                    | 2 000   | 2 000 |
|   |  | 12V and 15V output | Maximum                      | µF                    | 470     | 470   |

Note \* : For 9-36V input range, the current is derated at 80% at 9V and increases linearly to full current at 12V.

Note \*\* : The ripple output voltage is the periodic AC component imposed on the output voltage, an aperiodic and random component (noise) has also to be considered. This noise can be reduced by adding an external capacitor (typically 10nF/rated voltage depending on isolation requirement) connected between the pin *Gi* and the pin *Gout* of the converter. This capacitor should be layed-out as close as possible from the converter.

Note \*\*\* : For load regulation characteristics from 0% to full load, please see page 6.

### 3- Electrical Characteristics (continued)

Data are valid at +25°C, unless otherwise specified.

| Parameter                                     | Conditions  | Limit or typical | Units | Bi Output MGDB-25 |           |
|---|---|------------------|-------|-------------------|-----------|
|   |   |                  |       | 25 - H            | 25 - J    |
| <b>Input</b>                                  |   |                  |       |                   |           |
| Nominal input voltage                         | Full temperature range  | Nominal          | VDC   | 20                | 28        |
| Permanent input voltage range (Ui)            | Full temperature range  | Min. - Max.      | VDC   | 9-36              | 16-40     |
| Extended permanent input voltage              | Full load (Consult factory)                                       | Min. - Max.      | VDC   | /                 | 16-45     |
| Transient input voltage                       | Full load (Consult factory)                                       | Maximum          | VDC/S | 40/0,1            | 50/0,1    |
| Start up input voltage                        | Full load   | Minimum          | VDC   | 8.5               | 15        |
| Start up time                                 | Ui nominal within 3ms<br>Nominal output<br>Full load : resistive  | Maximum          | ms    | 30                | 30        |
| Reflected ripple current                      | Ui nominal, full load at switching freq. BW = 20MHz               | Typical          | mApp  | 300               | 300       |
| Input current in short circuit mode (Average) | Ui nominal<br>Short-circuit                                       | Maximum          | mA    | 40                | 40        |
| No load input current                         | Ui nominal<br>No load   | Maximum          | mA    | 60                | 60        |
| <b>Output</b>                                 |   |                  |       |                   |           |
| Output voltage                                | Full temperature range  | Nominal          | VDC   | +/- 5             | +/- 5     |
|   | Ui min. to max.   | Nominal          | VDC   | +/- 12            | +/- 12    |
|   | 75% load  | Nominal          | VDC   | +/- 15            | +/- 15    |
| Set Point accuracy                            | Ambient temperature : +25°C<br>Ui nominal, 75% load               | Maximum          | %     | +/- 2             | +/- 2     |
| Output power                                  | Full temperature range<br>Ui min. to max.                         | Maximum          | W     | +/- 12.5          | +/- 12.5  |
| Output current *                              | Full temperature range<br>Ui min. to max.                         | Maximum          | A     | +/- 2,5           | +/- 2,5   |
|   |   | Maximum          | A     | +/- 1             | +/- 1     |
|   |   | Maximum          | A     | +/- 0,825         | +/- 0,825 |
|   |   | Maximum          | A     | +/- 0,825         | +/- 0,825 |
| Ripple output voltage **                      | Ui nominal  | Maximum          | mVpp  | 50                | 50        |
|   | 5V output   | Maximum          | mVpp  | 100               | 100       |
|   | 12V output  | Maximum          | mVpp  | 150               | 150       |
|   | 15V output  | Maximum          | mVpp  | 150               | 150       |
| Line regulation                               | Ui min. to max.<br>Full load                                      | Typical          | %     | +/- 1             | +/- 1     |
| Load regulation ***                           | Ui nominal<br>25% to full load                                    | Typical          | %     | +/- 2,5           | +/- 2,5   |
| Cross load output regulation                  | Ui nominal<br>+ Vout nominal load<br>- Vout from 25% to full load | Typical          | %     | +/- 0,5           | +/- 0,5   |
| Efficiency                                    | Ui nominal<br>Full load   | Typical          | %     | See on page 6     |           |
| Maximum admissible Capacitive load            | Ui nominal  | Maximum          | µF    | 1 000             | 1 000     |
|   | 5V output   |                  |       |                   |           |
|   | 12V and 15V output  |                  |       |                   |           |
|   | Per output  | Maximum          | µF    | 220               | 220       |

Note \* : For 9-36V input range, the current is derated at 80% at 9V and increases linearly to full current at 12V.

Note \*\* : The ripple output voltage is the periodic AC component imposed on the output voltage, an aperiodic and random component (noise) has also to be considered. This noise can be reduced by adding an external capacitor (typically 10nF/rated voltage depending on isolation requirement) connected between the pin Gin and the pin Gout of the converter. This capacitor should be layed-out as close as possible from the converter.

Note \*\*\* : For load regulation characteristics from 0% to full load, please see page 6.

### 3- Electrical Characteristics (continued)

Data are valid at +25°C, unless otherwise specified.

| Parameter                                     | Conditions  | Limit or typical              | Units                | Tri Output MGD-25              |                                |
|---|---|-------------------------------|----------------------|--------------------------------|--------------------------------|
|   |   |                               |                      | 25 - H                         | 25 - J                         |
| <b>Input</b>                                  |   |                               |                      |                                |                                |
| Nominal input voltage                         | Full temperature range  | Nominal                       | VDC                  | 20                             | 28                             |
| Permanent input voltage range (Ui)            | Full temperature range  | Min. - Max.                   | VDC                  | 9-36                           | 16-40                          |
| Extended permanent input voltage              | Full load (Consult factory)                                       | Min. - Max.                   | VDC                  | /                              | 16-45                          |
| Transient input voltage                       | Full load (Consult factory)                                       | Maximum                       | VDC/S                | 40/0,1                         | 50/0,1                         |
| Start up input voltage                        | Full load   | Minimum                       | VDC                  | 8.5                            | 15                             |
| Start up time                                 | Ui nominal within 3ms<br>Nominal output<br>Full load : resistive  | Maximum                       | ms                   | 30                             | 30                             |
| Reflected ripple current                      | Ui nominal, full load at switching freq. BW = 20MHz               | Typical                       | mApp                 | 300                            | 300                            |
| Input current in short circuit mode (Average) | Ui nominal<br>Short-circuit                                       | Maximum                       | mA                   | 40                             | 40                             |
| No load input current                         | Ui nominal<br>No load   | Maximum                       | mA                   | 60                             | 60                             |
| <b>Output</b>                                 |   |                               |                      |                                |                                |
| Output voltage                                | Full temperature range<br>Ui min. to max.<br>75% load             | Nominal<br>Nominal            | VDC<br>VDC           | 5 & +/- 11,5<br>5 & +/- 14,6   | 5 & +/- 11,5<br>5 & +/- 14,6   |
| Set Point accuracy                            | Ambient temperature : +25°C<br>Ui nominal, 75% load               | Maximum                       | %                    | +/- 2                          | +/- 2                          |
| Output power                                  | Full temperature range<br>Ui min. to max.                         | Maximum                       | W                    | 12,5 & +/- 6,25                | 12,5 & +/- 6,25                |
| Output current *                              | Full temperature range<br>Ui min. to max.                         | Maximum<br>Maximum            | A<br>A               | 2,5 & +/- 0,5<br>2,5 & +/- 0,4 | 2,5 & +/- 0,5<br>2,5 & +/- 0,4 |
| Ripple output voltage **                      | Ui nominal<br>Full load<br>BW = 20MHz                             | Maximum<br>Maximum<br>Maximum | mVpp<br>mVpp<br>mVpp | 50<br>100<br>150               | 50<br>100<br>150               |
| Line regulation                               | Ui min. to max.<br>Full load                                      | Typical                       | %                    | +/- 1                          | +/- 1                          |
| Load regulation ***                           | Ui nominal<br>25% to full load                                    | Typical                       | %                    | +/- 3                          | +/- 3                          |
| Cross load output regulation                  | Ui nominal<br>+ Vout nominal load<br>- Vout from 25% to full load | Typical                       | %                    | +/- 0,5                        | +/- 0,5                        |
| Efficiency                                    | Ui nominal<br>Full load   | Typical                       | %                    | see on page 6                  |                                |
| Maximum admissible Capacitive load            | Ui nominal<br>Full load<br>Per output                             | Maximum<br>Maximum            | μF<br>μF             | 2 200<br>100                   | 2 200<br>100                   |

Note \* : For 9-36V input range, the current is derated at 80% at 9V and increases linearly to full current at 12V.

Note \*\* : The ripple output voltage is the periodic AC component imposed on the output voltage, an aperiodic and random component (noise) has also to be considered. This noise can be reduced by adding an external capacitor (typically 10nF/rated voltage depending on isolation requirement) connected between the pin Gin and the pin Gout of the converter. This capacitor should be layed-out as close as possible from the converter.

Note \*\*\* : For load regulation characteristics from 0% to full load, please see page 6.

### 3- Electrical Characteristics (continued)

**Figure 1 : Typical efficiency versus load at various input**

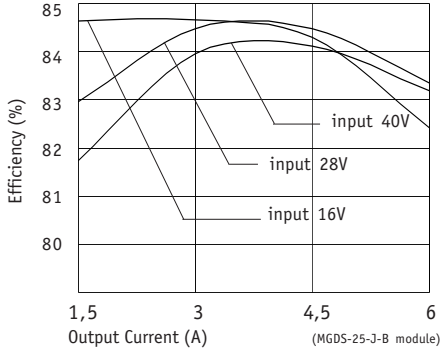

**Figure 2 : Typical efficiency versus load at various input**

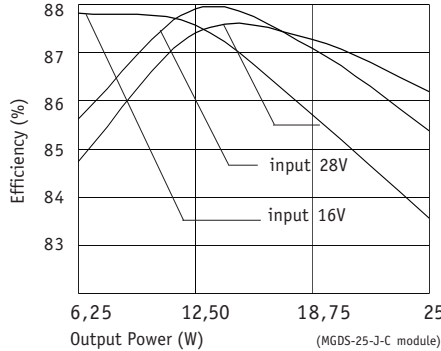

**Figure 3 : Typical efficiency versus load at various input**

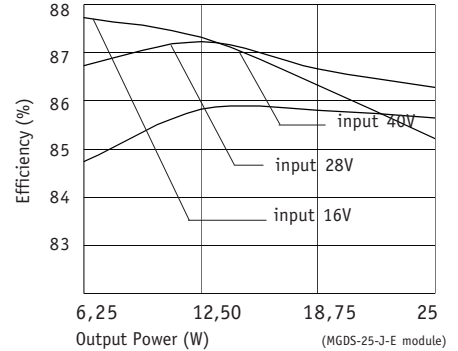

**Figure 4 : Typical efficiency versus load at various input**

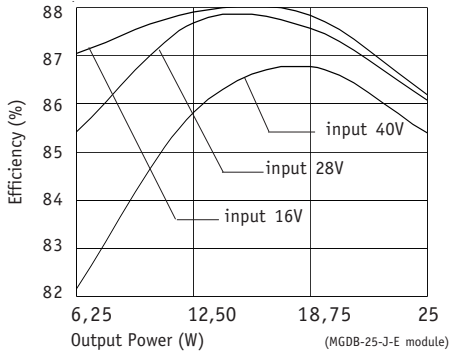

**Figure 5 : Typical efficiency versus load at various input**

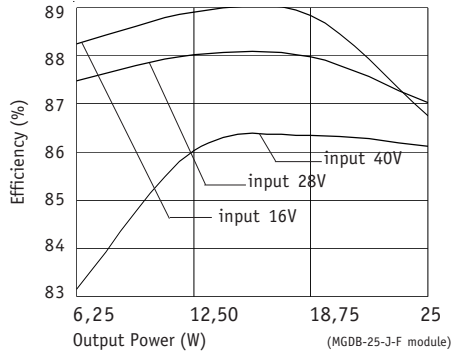

**Figure 6 : Typical efficiency versus load at various input**

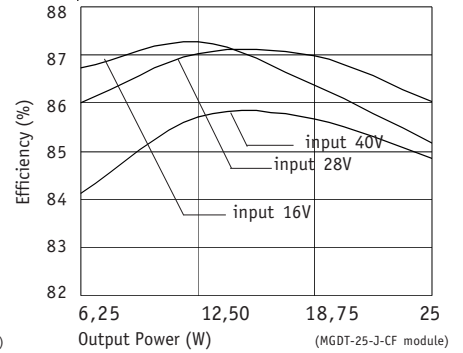

**Figure 7 : Typical load regulation characteristics at nominal input**

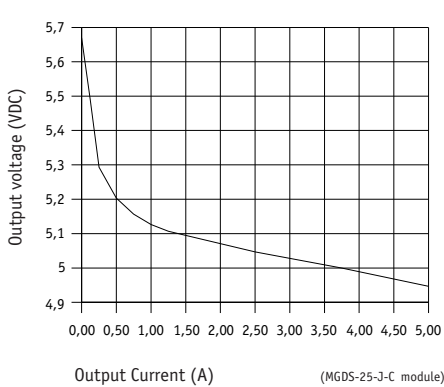

**Figure 8 : Typical load regulation characteristics at nominal input**

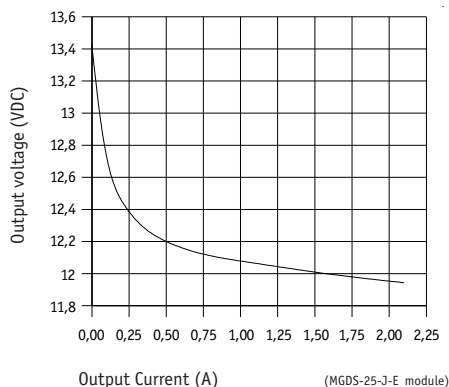

**Figure 9 : Typical load regulation characteristics at nominal input**

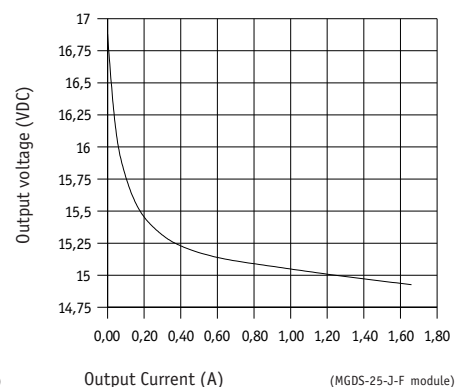

## 4- Switching Frequency

| Parameter           | Conditions  | Limit or typical | Specifications |
|---------------------|---|------------------|----------------|
| Switching frequency | Full temperature range<br>Ui min. to max.<br>No load to full load | Nominal, fixed   | 250 KHz        |

## 5- Isolation

| Parameter  | Conditions       | Limit or typical | Specifications    |
|--|------------------|------------------|-------------------|
| Electric strength test voltage   | Input to output  | Minimum          | 1 500 VDC / 1 min |
| Electric strength test voltage between outputs (for dual and triple outputs) | Output to output | Minimum          | No isolation      |
| Isolation resistance   | 500 VDC          | Minimum          | 100 MOhm          |

## 6- Protection Functions

| Characteristics                       | Protection Device                   | Recovery           | Limit or typical                         | Specifications   |
|---------------------------------------|-------------------------------------|--------------------|--|--|
| Output short circuit protection (SCP) | Hiccup circuitry with auto-recovery | Automatic recovery | Permanent                                | See section 11   |
| Output overvoltage protection (OVP)   | Zener clamp                         | /                  | Maximum<br>Maximum<br>Maximum<br>Maximum | For 3.3v : 4.6v<br>For 5v : 6v<br>For 12v : 14v<br>For 15v : 17v |

## 7- Reliability Data

| Characteristics  | Conditions                          | Temperature                     | Specifications             |
|--|-------------------------------------|---------------------------------|----------------------------|
| Mean Time Between Failure (MTBF)<br>According to MIL-HDBK-217F | Ground fixed (Gf)                   | Case at 40°C<br>Case at 85°C    | 925 000 Hrs<br>370 000 Hrs |
|  | Airborne, Inhabited,<br>Cargo (AIC) | Case at 40°C<br>Case at 85°C    | 535 000 Hrs<br>225 000 Hrs |
| Mean Time Between Failure (MTBF)<br>According to IEC-62380-TR  | Civilian avionics,<br>calculators   | Ambient at 55°C<br>100% time on | 977 000 Hrs                |

## 8- Electromagnetic Interference

Electromagnetic Interference requirements according to MIL-STD-461C/D/E standards can be easily achieved as indicated in the following section. The following table resumes the different sections covered by these standards.

| Standard Requirements   | MIL-STD-461C Standard | MIL-STD-461D/E Standard | Compliance with GAIA Converter Module & common mode capacitance      |
|---|-----------------------|-------------------------|--|
| <b>Conducted emission (CE) :</b><br>Low frequency<br>High frequency         | CE 01<br>CE 03        | CE 101<br>CE 102        | compliant module stand-alone<br>compliant with additional filter     |
| <b>Conducted susceptibility (CS) :</b><br>Low frequency<br>High frequency   | CS 01<br>CS 02        | CS 101<br>CS114         | compliant with additional filter<br>compliant with additional filter |
| <b>Radiated emission (RE) :</b><br>Magnetic field<br>Electrical field       | RE 01<br>RE 02        | RE 101<br>RE 102        | compliant module stand-alone<br>compliant module stand-alone         |
| <b>Radiated susceptibility (RS) :</b><br>Magnetic field<br>Electrical field | RS 01<br>RS 03        | RS 101<br>RS 103        | compliant module stand-alone<br>compliant module stand-alone         |

### 8-1 Module Compliance with MIL-STD-461C/D/E Standards

To meet the latest US military standards MIL-STD-461D/E (and also the MIL-STD-461C) requirements and in particular the conducted noise emission CE102 (and also CE03) requirements, Gaia Converter can propose a stand-alone ready-to-use EMI filter module. This EMI filter module has to be used together with a common mode noise capacitance  $C_c$  (10nF/rated voltage depending on isolation requirement) connected between  $G_{in}$  and  $G_{out}$ .

EMI Filter module reference : FGDS-2A-50V.  
Please consult EMI filter datasheet for further details.

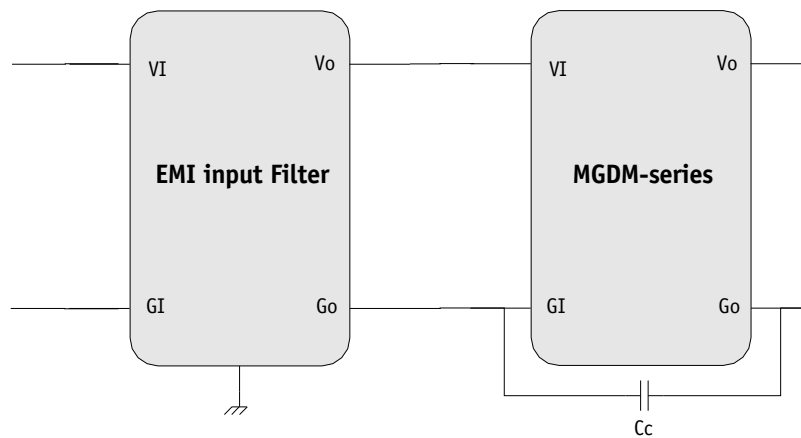



## 9- Thermal Characteristics

| Characteristics                                  | Conditions   | Limit or typical   | Performances      |
|--|--|--------------------|-------------------|
| Operating ambient temperature range at full load | Ambient temperature *                              | Minimum<br>Maximum | - 40°C<br>+ 85°C  |
| Operating case temperature range at full load    | Case temperature                                   | Minimum<br>Maximum | - 40°C<br>+ 105°C |
| Storage temperature range                        | Non functioning                                    | Minimum<br>Maximum | - 55°C<br>+ 125°C |
| Thermal resistance                               | Rth case to ambient in free air natural convection | Typical            | 7°C /W            |

Note \* : The upper temperature range depends on configuration, the user must assure a max. case temperature of + 105°C.

The MGDM-25 series operating **case** temperature must not exceed 105°C. The maximum **ambient** temperature admissible for the DC/DC converter corresponding to the maximum operating case temperature of 105°C depends on the ambient airflow, the mounting/orientation, the cooling features and the power dissipated.

To calculate a maximum admissible ambient temperature the following method can be used. Knowing the maximum case temperature Tcase = 105°C of the module, the power used Pout and the efficiency  $\eta$  :

- determine the power dissipated by the module P<sub>diss</sub> that should be evacuated :

$$P_{diss} = P_{out}(1/\eta - 1)$$

- determine the maximum ambient temperature :

$$T_a = 105^\circ\text{C} - R_{th} \times P_{diss}$$

where **Rth** is the thermal resistance from the case to ambient.

The previous thermal calculation shows two areas of operation :

- a normal operation area in a free natural ambient convection (grey area in this following graph),
- an area with cooling features (air flow or heatsink) ensuring a maximum case temperature below the maximum operating case temperature of 105°C (white area in the following graph).

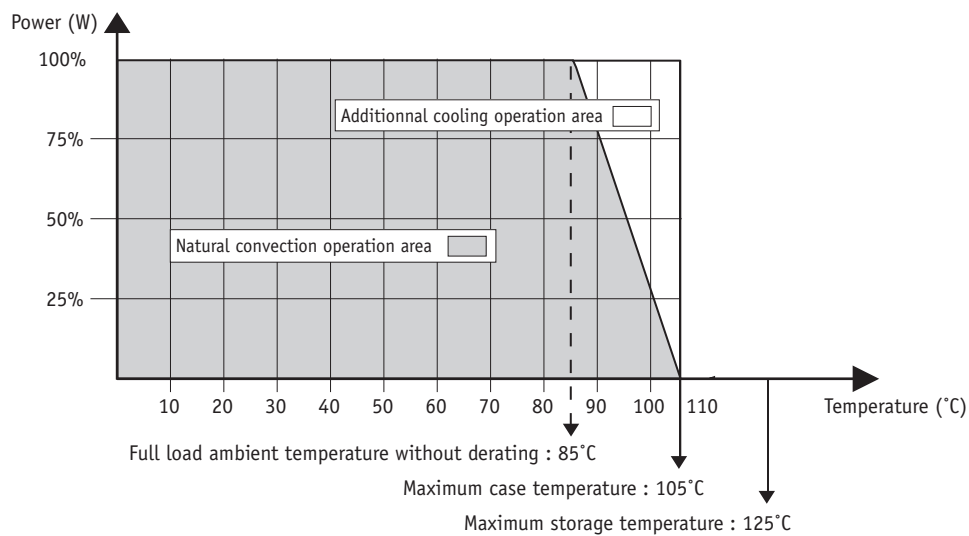

## 10- Environmental Qualifications

The modules have been subjected to the following environmental qualifications.

| Characteristics                  | Conditions  | Severity   | Test procedure               |
|----------------------------------|---|--|------------------------------|
| <b>Climatic Qualifications</b>   |   |  |                              |
| Life at high temperature         | Duration<br>Temperature / status of unit  | Test D : 1 000 Hrs<br>@ 105°C case, unit operating<br>@ 125°C ambient, unit not operating                            | MIL-STD-202G<br>Method 108A  |
| Altitude                         | Altitude level C<br>Duration<br>Climb up<br>Stabilization<br>Status of unit                                 | 40 000 ft@-55°C<br>30 min.<br>1 000 ft/min to 70 000 ft@-55°C,<br>30 min.<br>unit operating                          | MIL-STD-810E<br>Method 500.3 |
| Humidity cyclic                  | Number of cycle<br>Cycle duration<br>Relative humidity variation<br>Temperature variation<br>Status of unit | 10<br>Cycle I : 24 Hrs<br>60 % to 88 %<br>31°C to 41°C<br>unit not operating   | MIL-STD-810E<br>Method 507.3 |
| Humidity steady                  | Damp heat<br>Temperature<br>Duration<br>Status of unit  | 93 % relative humidity<br>40°C<br>56 days<br>unit not operating  | MIL-STD-202G<br>Method 103B  |
| Salt atmosphere                  | Temperature<br>Concentration NaCl<br>Duration<br>Status of unit   | 35°C<br>5 %<br>48 Hrs<br>unit not operating  | MIL-STD-810E<br>Method 509.3 |
| Temperature cycling              | Number of cycles<br>Temperature change<br>Transfert time<br>Steady state time<br>Status of unit             | 200<br>-40°C / +85°C<br>40 min.<br>20 min.<br>unit operating   | MIL-STD-202A<br>Method 102A  |
| Temperature shock                | Number of shocks<br>Temperature change<br>Transfert time<br>Steady state time<br>Status of unit             | 100<br>-55°C / +105°C<br>10 sec.<br>20 min.<br>unit not operating  | MIL-STD-202G<br>Method 107G  |
| <b>Mechanical Qualifications</b> |   |  |                              |
| Vibration (Sinusoidal)           | Number of cycles<br>Frequency / amplitude<br>Frequency / acceleration<br>Duration<br>Status of unit         | 10 cycles in each axis<br>10 to 60 Hz / 0.7 mm<br>60 to 2 000 Hz / 10 g<br>2h 30 min. per axis<br>unit not operating | MIL-STD-810D<br>Method 514.3 |
| Shock (Half sinus)               | Number of shocks<br>Peak acceleration<br>Duration<br>Shock form<br>Status of unit                           | 3 shocks in each axis<br>100 g<br>6 ms<br>1/2 sinusoidal<br>unit not operating                                       | MIL-STD-810D<br>Method 516.3 |
| Bump (Half sinus)                | Number of bumps<br>Peak acceleration<br>Duration<br>Status of unit  | 2 000 bumps in each axis<br>40 g<br>6 ms<br>unit not operating   | MIL-STD-810D<br>Method 516.3 |

## 11- Description of Protections

### 11-1 Output Short Circuit Protection (SCP)

The short circuit protection device protects the module against short circuit of any duration and restores the module to normal operation when the short circuit is removed. It operates in «hiccup» mode by testing periodically if an overload is applied (typically every 1s recovery time). The overload detection threshold is typically 200% of maximum current with a detection time lower than 5ms.

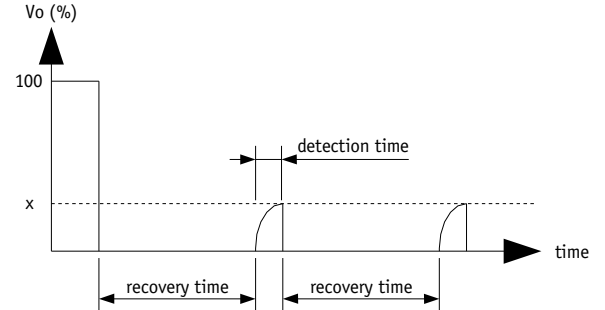

### 11-2 Output Overvoltage Protection (OVP)

The output overvoltage protection device protects external components against high voltage or possible overvoltages which can be supplied by the module (i.e in case of internal failure). It consists of a zener diode clamping the output voltage; under worst case conditions this zener diode will short-circuit.

The output voltage protection is not designed to withstand externally applied output overvoltages to protect the module itself.

4

## 12- Description of Functions

### 12-1 On/Off Function

The control pin 4 (On/Off) can be used for applications requiring On/Off operation. By using an open collector command with a transistor Q referenced to the common terminal (Gi) :

- A logic pulled low (<math>\approx 0.2V@1mA</math>, referenced to Gi) on pin 4 disables the converter
- No connection or high impedance on pin 4 enables the converter.

By releasing the On/Off function, the converter will restart within the start-up time specifications given in table page 3. For further details please consult "Logic On/Off" Application Note.

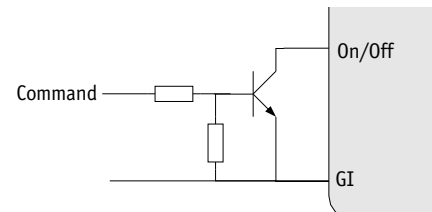

### 13- Application Notes

#### 13-1 Connection of Outputs in Series

Any of the bi output converters can be configured to produce an output of 10V (+/-5 output models), 24V (+/-12V output models), or 30V (+/-15V output models) by connecting the load across the output (+) and the output (-) with either output grounded, and leaving the common pin floating.

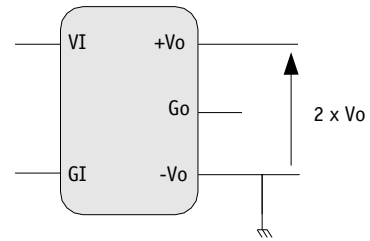

#### 13-2 Connection of Modules in Series

The output of single output units can be connected in series without any precautions to provide higher output voltage level.

Nevertheless, GAIA Converter recommends to protect each individual output by a low power shottky diode rated with the maximum current of the converter to avoid reverse polarity at any output.

Reverse polarity may occur at start up if the output voltages do not rise at the same time.

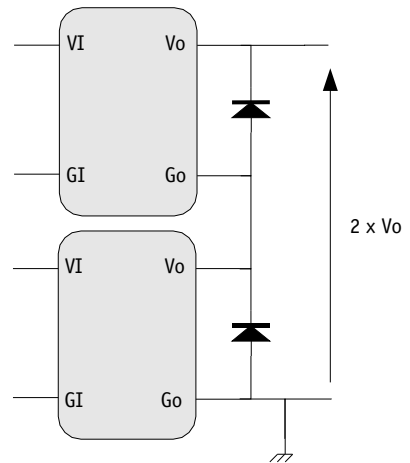

#### 13-3 Connection of Modules in Parallel

Several converters with equal output voltage can be connected in parallel to increase power. Nevertheless some cares have to be taken in particular as the output voltage of each converter is slightly different, when paralleling, the converter with the highest output voltage will source the most current.

However the GAIA Converter modules are designed with a "soft" output voltage versus current characteristic. This causes the output voltage of each converter to automatically adjust downward as its current increases so each converter very approximately shares the total output current. It is important that each converter has approximately the same impedance between their output and the common load.

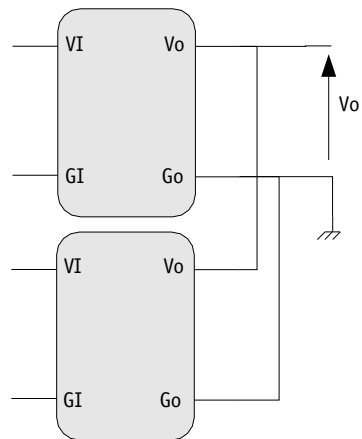

## 14- Dimensions

Dimension are given in mm (inches). Tolerance : +/- 0,2 mm (+/- 0.01 ") unless otherwise indicated.  
Weight : 80 grams (2.8 Ozs) max.

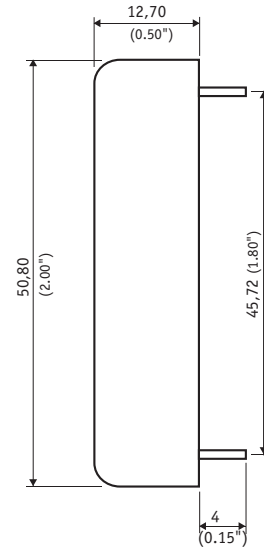
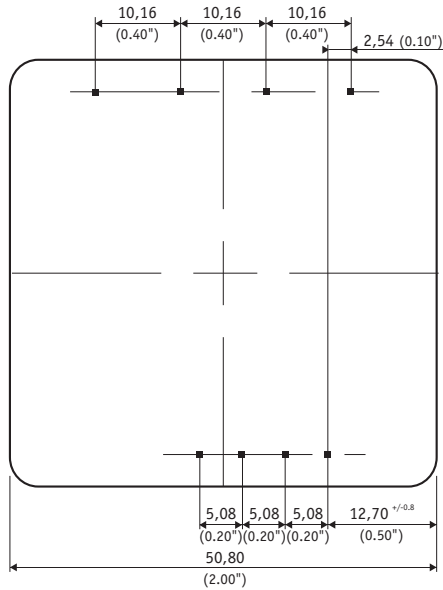

Pin dimensions :  $\square$  0,91 mm (0.036 ")

## 15- Materials

Case : Metallic black anodized coating.

Pins : Plated with pure matte tin over nickel underplate.

## 16- Product Marking

Upper face : Company logo, location of manufacturing.

Side face : Module reference : MGDx-25-»X»-»Y».

Date code : year and week of manufacturing, suffix, /option.

## 17- Connections

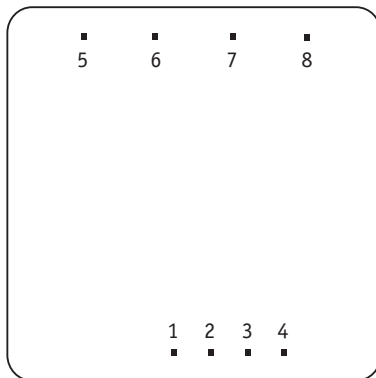

Bottom view

| Pin | Single         | Bi             | Triple          |
|-----|----------------|----------------|-----------------|
| 1   | + Input (Vi)   | + Input (Vi)   | + Input (Vi)    |
| 2   | - Input (Gi)   | - Input (Gi)   | - Input (Gi)    |
| 3   | Case           | Case           | Case            |
| 4   | Non connected* | Non connected* | Non connected*  |
| 5   | Do not connect | Output + (+Vo) | Output 2+ (+V2) |
| 6   | Output (Vo)    | Common (Go)    | Output 1 (V1)   |
| 7   | Common (Go)    | Output - (-Vo) | Common (Go)     |
| 8   | Do not connect | Do not connect | Output 2- (-V2) |

\* Option /M : Pin 4 connected for On/Off function.  
Please add /M to module reference.



For more detailed specifications and applications information, contact :

**International Headquarters**

GAIA Converter - France  
ZI de la Morandière  
33185 LE HAILLAN - FRANCE  
Tel. : + (33)-5-57-92-12-80  
Fax : + (33)-5-57-92-12-89

**North American Headquarters**

GAIA Converter Canada, Inc  
4038 Le Corbusier Blvd  
LAVAL, QUEBEC - CANADA H7L 5R2  
Tel. : (514)-333-3169  
Fax : (514)-333-4519

Represented by :