

Three-Terminal Low Current Positive Voltage Regulators BL78LXX

FEATURES

- Wide range of available, fixed output voltage.
- Low cost.
- Internal short-circuit current limiting.
- Internal thermal overload protection.
- No external components required.
- Complementary negative regulators offered (BL79LXX series).

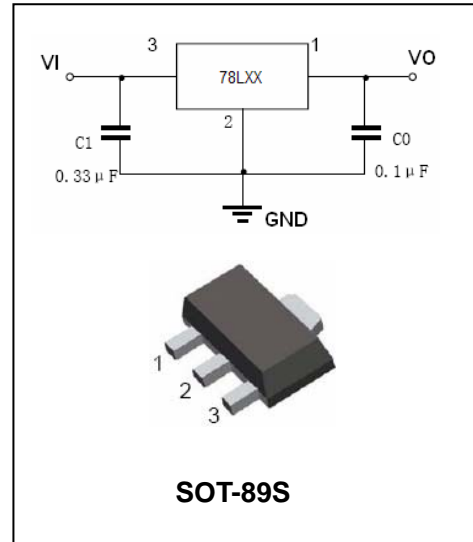

APPLICATIONS

- Three-terminal positive voltage regulator.

ORDERING INFORMATION

Type No.	Marking	Package Code
BL78LXX	78LXX	SOT-89S

MAXIMUM RATING operating temperature range applies unless otherwise specified

Symbol	Parameter	Value	Units
V_I	Input voltage(3.3V-9V)	30	V
	(10V-15V)	35	
	(18V-24V)	40	
I_{CM}	Maximum output current	100	mA
$R_{th\ j-c}$	Thermal Resistance, Junction to Case	250	°C/W
P_D	Power dissipation	500	mW
T_{OPR}	Operating junction temperature	0 to +125	°C
T_j, T_{stg}	Storage temperature range	-40 to +150	°C



Three-Terminal Low Current Positive Voltage Regulators BL78LXX

ELECTRICAL CHARACTERISTICS

($V_{IN}=8.3V, I_O=40mA, 0^{\circ}C < T_J < 125^{\circ}C, C_I=0.33\mu F, C_O=0.1\mu F$, unless otherwise specified)

Parameter	Symbol	Test conditions	BL78L33			UNIT
			MIN	TYP	MAX	
Output voltage	V_O	$T_J=25^{\circ}C$ $5.3V \leq V_i \leq 20V, I_O=1mA-40mA$ $V_1=8.3V, I_O=1mA-70mA$	3.168 3.135 3.135	3.3	3.432 3.465 3.465	V
Load regulation	Reg_{load}	$T_J=25^{\circ}C, I_O=1mA-100mA$ $T_J=25^{\circ}C, I_O=1mA-40mA$			60 30	mV
Line regulation	Reg_{line}	$5.3V \leq V_i \leq 20V, T_J=25^{\circ}C$ $6.3V \leq V_i \leq 20V, T_J=25^{\circ}C$			150 100	mV
Input Bias Current	I_{IB}	$T_J=25^{\circ}C$ $T_J=125^{\circ}C$			6.0 5.5	mA
Input Bias Current Change	ΔI_{IB}	$6.3V \leq V_i \leq 20V$ $1mA \leq I_O \leq 40mA$			1.5 0.1	mA
Output noise voltage	V_N	$10Hz \leq f \leq 100KHz$		40		μV
Ripple rejection	RR	$I_O=40mA, 6.3V \leq V_i \leq 16.3V$ $f=120Hz, T_J=25^{\circ}C$	41	49		dB
Dropout voltage	V_I-V_O	$T_J=25^{\circ}C$		1.7		V

ELECTRICAL CHARACTERISTICS

($V_{IN}=10V, I_O=40mA, 0^{\circ}C < T_J < 125^{\circ}C, C_I=0.33\mu F, C_O=0.1\mu F$, unless otherwise specified)

Parameter	Symbol	Test conditions	BL78L05			UNIT
			MIN	TYP	MAX	
Output voltage	V_O	$T_J=25^{\circ}C$ $7V \leq V_i \leq 20V, I_O=1mA-40mA$ $V_1=10V, I_O=1mA-70mA$	4.8 4.75 4.75	5.0	5.2 5.25 5.25	V
Load regulation	Reg_{load}	$T_J=25^{\circ}C, I_O=1mA-100mA$ $T_J=25^{\circ}C, I_O=1mA-40mA$		11 5	60 30	mV
Line regulation	Reg_{line}	$7V \leq V_i \leq 20V, T_J=25^{\circ}C$ $8V \leq V_i \leq 20V, T_J=25^{\circ}C$		55 45	150 100	mV
Input Bias Current	I_{IB}	$T_J=25^{\circ}C$ $T_J=125^{\circ}C$		3.8	6.0 5.5	mA
Input Bias Current Change	ΔI_{IB}	$8V \leq V_i \leq 20V$ $1mA \leq I_O \leq 40mA$			1.5 0.1	mA
Output noise voltage	V_N	$10Hz \leq f \leq 100KHz$		40		μV
Ripple rejection	RR	$I_O=40mA, 8V \leq V_i \leq 18V, f=120Hz$ $T_J=25^{\circ}C$	41	49		dB
Dropout voltage	V_I-V_O	$T_J=25^{\circ}C$		1.7		V



Three-Terminal Low Current Positive Voltage Regulators BL78LXX

ELECTRICAL CHARACTERISTICS

($V_{IN}=12V, I_O=40mA, 0^\circ C < T_j < 125^\circ C, C_I=0.33\mu F, C_O=0.1\mu F$, unless otherwise specified)

Parameter	Symbol	Test conditions	BL78L06			UNIT
			MIN	TYP	MAX	
Output voltage	V_O	$T_j=25^\circ C$	5.75	6.0	6.25	V
		$V_1=8.5V-20V, I_O=1mA-40mA$	5.7		6.3	
		$V_1=8.5V, I_O=1mA-70mA$	5.7		6.3	
Load regulation	Reg_{load}	$T_j=25^\circ C, I_O=1mA-100mA$		12.8	80	mV
		$T_j=25^\circ C, I_O=1mA-70mA$		5.8	40	
Line regulation	Reg_{line}	$8.5V \leq V_i \leq 20V, T_j=25^\circ C$		64	175	mV
		$9V \leq V_i \leq 20V, T_j=25^\circ C$		54	125	
Input Bias Current	I_{IB}	$T_j=25^\circ C, V_{IN}=12V, I_O=40mA$			5.5	mA
		$T_j=125^\circ C, V_{IN}=12V, I_O=40mA$		3.9	6.0	
Input Bias Current Change	ΔI_{IB}	$9V \leq V_i \leq 20V$			1.5	mA
		$1mA \leq I_O \leq 40mA$			0.1	
Output noise voltage	V_N	$10Hz \leq f \leq 100KHz$		40		$\mu V/V_O$
Ripple rejection	RR	$I_O=40mA, 10V \leq V_i \leq 20V, f=120Hz, T_j=25^\circ C$	40	46		dB
Dropout voltage	V_D	$T_j=25^\circ C$		1.7		V

ELECTRICAL CHARACTERISTICS

($V_{IN}=14V, I_O=40mA, 0^\circ C < T_j < 125^\circ C, C_I=0.33\mu F, C_O=0.1\mu F$, unless otherwise specified)

Parameter	Symbol	Test conditions	BL78L08			UNIT
			MIN	TYP	MAX	
Output voltage	V_O	$T_j=25^\circ C$	7.7	8.0	8.3	V
		$10.5V \leq V_i \leq 23V, I_O=1mA-40mA$	7.6		8.4	
		$V_1=14V, I_O=1mA-70mA$	7.6		8.4	
Load regulation	Reg_{load}	$T_j=25^\circ C, I_O=1mA-100mA$		15	80	mV
		$T_j=25^\circ C, I_O=1mA-40mA$		8.0	40	
Line regulation	Reg_{line}	$10.5V \leq V_i \leq 23V, T_j=25^\circ C$		20	175	mV
		$11V \leq V_i \leq 23V, T_j=25^\circ C$		12	125	
Input Bias Current	I_{IB}	$T_j=25^\circ C$		3	6.0	mA
		$T_j=125^\circ C$			5.5	
Input Bias Current Change	ΔI_{IB}	$11V \leq V_i \leq 23V$			1.5	mA
		$1mA \leq I_O \leq 40mA$			0.1	
Output noise voltage	V_N	$T_A=25^\circ C, 10Hz \leq f \leq 100KHz$		60		μV
Ripple rejection	RR	$I_O=40mA, 12V \leq V_i \leq 23V, f=120Hz, T_j=25^\circ C$	37	57		dB
Dropout voltage	V_I-V_O	$T_j=25^\circ C$		1.7		V



Three-Terminal Low Current Positive Voltage Regulators BL78LXX

ELECTRICAL CHARACTERISTICS

($V_{IN}=15V, I_O=40mA, 0^\circ C < T_j < 125^\circ C, C_I=0.33\mu F, C_O=0.1\mu F$, unless otherwise specified)

Parameter	Symbol	Test conditions	BL78L09			UNIT
			MIN	TYP	MAX	
Output voltage	V_O	$T_j=25^\circ C$	8.6	9.0	9.4	V
		$V_i=11.5V-24V, I_O=1mA-40mA$	8.5		9.5	
		$V_i=15V, I_O=1mA-70mA$	8.5		9.5	
Load regulation	Reg_{load}	$T_j=25^\circ C, I_O=1mA-100mA$		15	90	mV
		$T_j=25^\circ C, I_O=1mA-40mA$		8.0	40	
Line regulation	Reg_{line}	$11.5V \leq V_i \leq 24V, T_j=25^\circ C$		20	175	mV
		$12V \leq V_i \leq 24V, T_j=25^\circ C$		12	125	
Input Bias Current	I_{IB}	$T_j=25^\circ C$		3.0	6.0	mA
		$T_j=125^\circ C$			5.5	
Input Bias Current Change	ΔI_{IB}	$11V \leq V_i \leq 23V$ $1mA \leq I_O \leq 40mA$			1.5 0.1	mA
Output noise voltage	V_N	$T_A=25^\circ C, 10Hz \leq f \leq 100KHz$		60		μV
Ripple rejection	RR	$I_O=40mA, 13V \leq V_i \leq 24V, f=120Hz, T_j=25^\circ C$	37	57		dB
Dropout voltage	V_I-V_O	$T_j=25^\circ C$		1.7		V



Three-Terminal Low Current Positive Voltage Regulators BL78LXX

ELECTRICAL CHARACTERISTICS

($V_{IN}=16V, I_O=40mA, C_{IN}=0.33\mu F, C_O=0.1\mu f, T_j = 0$ to $125^\circ C$, unless otherwise specified)

Parameter	Symbol	Test conditions	BL78L10			UNIT
			MIN	TYP	MAX	
Output voltage	V_O	$T_j=25^\circ C$	9.6	10	10.4	V
Load regulation(Note1)	ΔReg_{load}	$I_O = 1$ to $100mA, T_j = 25^\circ C$	-	17	90	mV
		$I_O = 1$ to $40mA, T_j = 25^\circ C$	-	9	45	mV
Line regulation(Note1)	ΔReg_{line}	$V_I = 12.5$ to $25V, T_j = 25^\circ C$	-	100	210	mV
		$V_I = 13$ to $25V, T_j = 25^\circ C$	-	90	160	mV
Input Bias Current	I_{IB}	$T_j = 25^\circ C$	-	2.0	3.0	mA
Input Bias Current Change	ΔI_{IB}	$V_I = 13$ to $25V, T_j = 25^\circ C$	-	-	1.0	mA
Output Noise Voltage	V_N	$10Hz \leq f \leq 100KHz$	-	70	-	μV
Ripple Rejection	RR	$V_I = 13$ to $23V, I_O = 40mA, f = 120Hz$	42	52	-	dB
Dropout Voltage	V_D	$T_j=25^\circ C$	-	1.7	-	V
Dropout voltage	V_I-V_O	$I_O = 5mA, T_j = 0$ to $125^\circ C$	-	0.9	-	$mV/^\circ C$



Three-Terminal Low Current Positive Voltage Regulators BL78LXX

ELECTRICAL CHARACTERISTICS

($V_{IN}=19V, I_O=40mA, 0^\circ C < T_J < 125^\circ C, C_I=0.33\mu F, C_O=0.1\mu F$, unless otherwise specified)

Parameter	Symbol	Test conditions	BL78L12			UNIT
			MIN	TYP	MAX	
Output voltage	V_O	$T_J=25^\circ C$ $V_I=14.5V-27V, I_O=1mA-40mA$ $V_I=19V, I_O=1mA-70mA$	11.5 11.4 11.4	12	12.5 12.6 12.6	V
Load regulation	Reg_{load}	$T_J=25^\circ C, I_O=1mA-100mA$ $T_J=25^\circ C, I_O=1mA-40mA$		20 10	100 50	mV
Line regulation	Reg_{line}	$14.5V \leq V_i \leq 27V, T_J=25^\circ C$ $16V \leq V_i \leq 27V, T_J=25^\circ C$		120 100	250 200	mV
Input Bias Current	I_{IB}	$T_J=25^\circ C$ $T_J=125^\circ C$		4.2	6.5 6.0	mA
Input Bias Current Change	ΔI_{IB}	$16V \leq V_i \leq 27V$ $1mA \leq I_O \leq 40mA$			1.5 0.1	mA
Output Noise Voltage	V_N	$10Hz \leq f \leq 100KHz, T_A=25^\circ C$		80		μV
Ripple rejection	RR	$I_O=40mA, 15V \leq V_i \leq 25V, f=120Hz,$ $T_J=25^\circ C$	37	42		dB
Dropout voltage	V_I-V_O	$T_J=25^\circ C$		1.7		V

ELECTRICAL CHARACTERISTICS

($V_{IN}=23V, I_O=40mA, 0^\circ C < T_J < 125^\circ C, C_I=0.33\mu F, C_O=0.1\mu F$, unless otherwise specified)

Parameter	Symbol	Test conditions	BL78L15			UNIT
			MIN	TYP	MAX	
Output voltage	V_O	$T_J=25^\circ C$ $V_i=17.5V-30V, I_O=1mA-40mA$ $V_i=23V, I_O=1mA-70mA$	14.4 14.25 14.25	15	15.6 15.75 15.75	V
Load regulation	ΔReg_{load}	$T_J=25^\circ C, I_O=1mA-100mA$ $T_J=25^\circ C, I_O=1mA-40mA$		25 12	150 75	mV
Line regulation	ΔReg_{line}	$17.5V \leq V_i \leq 30V, T_J=25^\circ C$ $20V \leq V_i \leq 30V, T_J=25^\circ C$		130 110	300 250	mV
Input Bias Current	I_{IB}	$T_J=25^\circ C$ $T_J=125^\circ C$		4.4	6.5 6.0	mA
Input Bias Current Change	ΔI_{IB}	$20V \leq V_i \leq 30V$ $1mA \leq I_O \leq 40mA$			1.5 0.1	mA
Output noise voltage	V_N	$10Hz \leq f \leq 100KHz, T_A=25^\circ C$		90		μV
Ripple rejection	RR	$I_O=40mA, 18.5V \leq V_i \leq 28.5V,$ $f=120Hz, T_J=25^\circ C$	34	39		dB
Dropout voltage	V_I-V_O	$T_J=25^\circ C$		1.7		V



Three-Terminal Low Current Positive Voltage Regulators BL78LXX

ELECTRICAL CHARACTERISTICS

($V_{IN}=27V, I_O=40mA, 0^\circ C < T_J < 125^\circ C, C_I=0.33\mu F, C_O=0.1\mu F$, unless otherwise specified)

Parameter	Symbol	Test conditions	BL78L18			UNIT
			MIN	TYP	MAX	
Output voltage	V_O	$T_J=25^\circ C$ $V_I=20.7V-33V, I_O=1mA-40mA$ $V_I=27V, I_O=1mA-70mA$	17.3 17.1 17.1	18	18.7 18.9 18.9	V
Load regulation	Reg_{load}	$T_J=25^\circ C, I_O=1mA-100mA$ $T_J=25^\circ C, I_O=1mA-40mA$		30 15	170 85	mV
Line regulation	Reg_{line}	$20.7V \leq V_i \leq 33V, T_J=25^\circ C$ $21V \leq V_i \leq 33V, T_J=25^\circ C$		45 35	325 275	mV
Input Bias Current	I_{IB}	$T_J=25^\circ C$ $T_J=125^\circ C$		3.1	6.5 6.0	mA
Input Bias Current Change	ΔI_{IB}	$21V \leq V_i \leq 33V$ $1mA \leq I_O \leq 40mA$			1.5 0.1	mA
Output Noise Voltage	V_N	$10Hz \leq f \leq 100KHz, T_A=25^\circ C$		150		μV
Ripple rejection	RR	$I_O=40mA, 23V \leq V_i \leq 33V, f=120Hz,$ $T_J=25^\circ C$	33	48		dB
Dropout voltage	V_I-V_O	$T_J=25^\circ C$		1.7		V

ELECTRICAL CHARACTERISTICS

($V_{IN}=33V, I_O=40mA, 0^\circ C < T_J < 125^\circ C, C_I=0.33\mu F, C_O=0.1\mu F$, unless otherwise specified)

Parameter	Symbol	Test conditions	BL78L24			UNIT
			MIN	TYP	MAX	
Output voltage	V_O	$T_J=25^\circ C$ $V_i=27V-38V, I_O=1mA-40mA$ $V_i=27V-33V, I_O=1mA-70mA$	23 22.8 22.8	24	25 25.2 25.2	V
Load regulation	ΔReg_{load}	$T_J=25^\circ C, I_O=1mA-100mA$ $T_J=25^\circ C, I_O=1mA-40mA$		40 20	200 100	mV
Line regulation	ΔReg_{line}	$28V \leq V_i \leq 80V, T_J=25^\circ C$ $27V \leq V_i \leq 38V, T_J=25^\circ C$		50 60	300 350	mV
Input Bias Current	I_{IB}	$T_J=25^\circ C$ $T_J=125^\circ C$		3.1	6.5 6.0	mA
Input Bias Current Change	ΔI_{IB}	$28V \leq V_i \leq 38V$ $1mA \leq I_O \leq 40mA$			1.5 0.1	mA
Output noise voltage	V_N	$10Hz \leq f \leq 100KHz, T_A=25^\circ C$		200		μV
Ripple rejection	RR	$I_O=40mA, 29V \leq V_i \leq 35V,$ $f=120Hz, T_J=25^\circ C$	31	45		dB
Dropout voltage	V_I-V_O	$T_J=25^\circ C$		1.7		V

Three-Terminal Low Current Positive Voltage Regulators BL78LXX

TYPICAL CHARACTERISTICS @ $T_a=25^\circ\text{C}$ unless otherwise specified

Figure 1. Dropout Characteristics

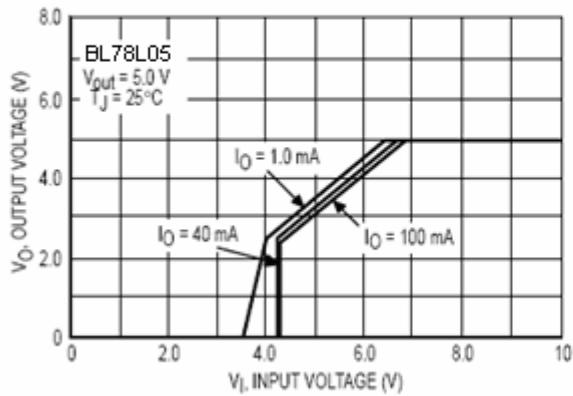

Figure 2. Dropout Voltage versus Junction Temperature

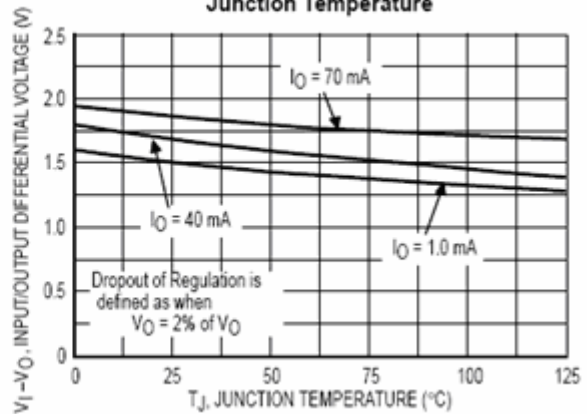

Figure 3. Input Bias Current versus Ambient Temperature

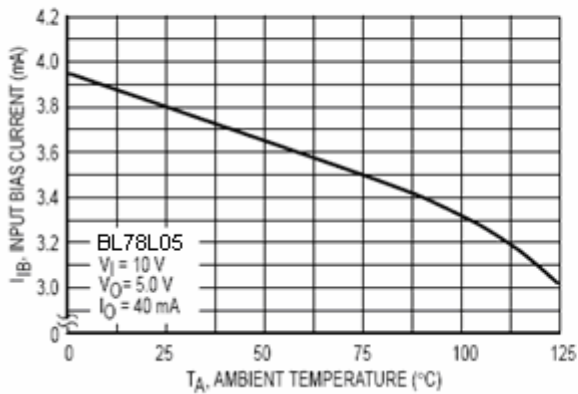
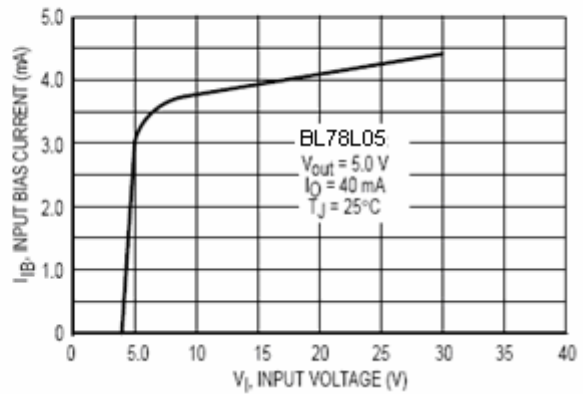

Figure 4. Input Bias Current versus Input Voltage



Three-Terminal Low Current Positive Voltage Regulators BL78LXX

PACKAGE OUTLINE

Plastic surface mounted package

SOT-89S

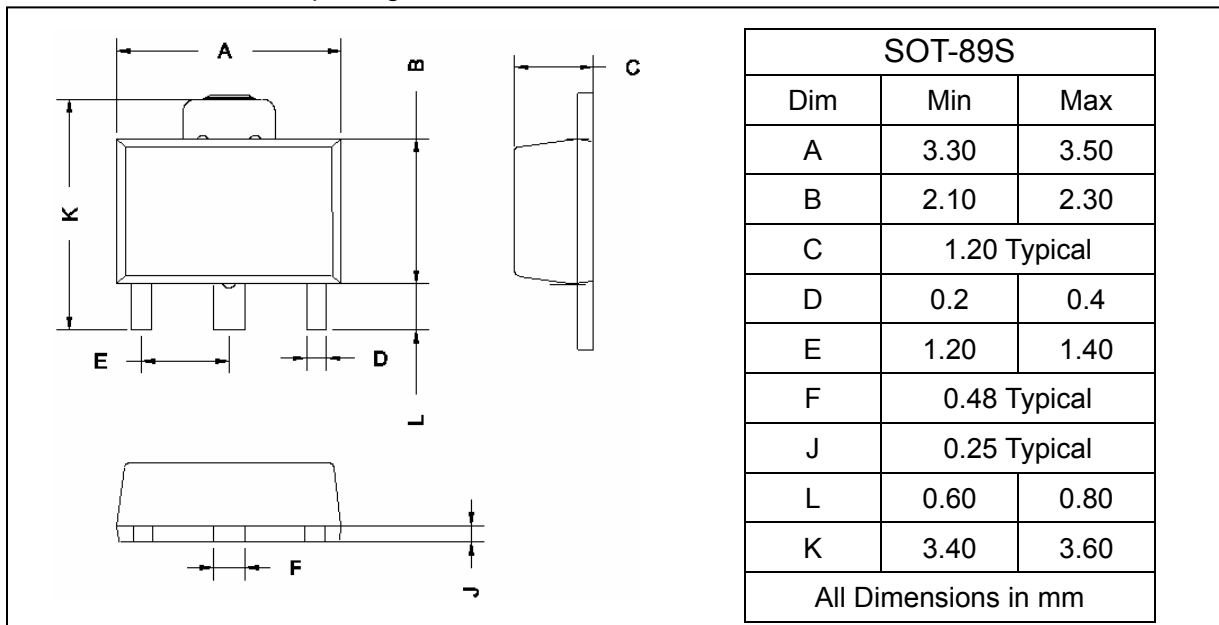

SOLDERING FOOTPRINT

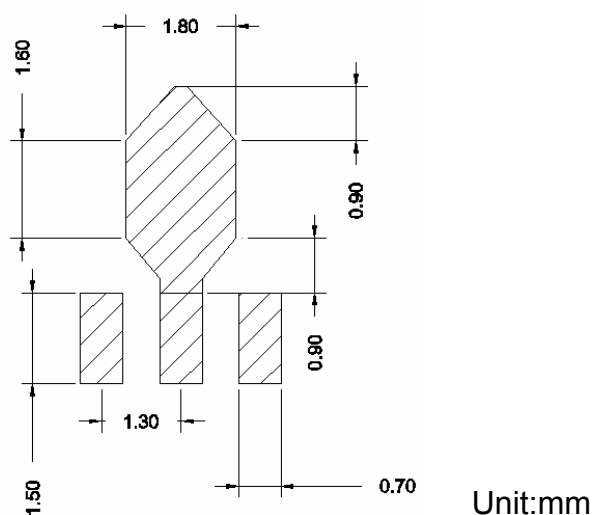

PACKAGE INFORMATION

Device	Package	Shipping
BL78LXX	SOT-89S	1500/Tape&Reel