



## Solutions

# Packaging Machinery

# Packaging Machinery

## Solutions for

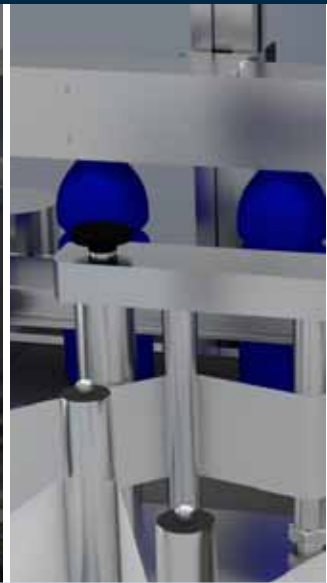

**Filling**

**Inspection**

**Wrapping  
and sealing**

**Labelling**

### **ABOUT CARLO GAVAZZI**

Carlo Gavazzi Automation is an international group active in designing, manufacturing and marketing electronic equipment targeted at the global markets of industrial and building automation.

Our history is full of firsts and our products are installed in a huge number of applications all over the world. With more than 80 years of successful operation, our experience is unparalleled.

We have our headquarters in Europe and numerous offices around the world.

Our R&D competence centres and production sites are located in Denmark, Italy, Lithuania, Malta and the People's Republic of China.

We operate worldwide through 22 of our own sales companies and also selected representatives in more than 65 countries, from the United States in the West to the Pacific Rim in the East.

Our core competence in automation spans four product lines: Sensors, Switches, Controls and Fieldbuses.

Our wide array of products includes sensors, monitoring relays, timers, energy management system, solid state relays, safety devices and fieldbus systems.

We focus our expertise on offering state-of-the-art product solutions in selected market segments.

Our customers include original equipment manufacturers of packaging machines, plastic-injection moulding machines, food and beverage production machines, conveying and material handling equipment, door and entrance control systems, lifts and escalators, as well as heating, ventilation and air-conditioning devices.



## DESIGNED TO MEET MARKET REQUIREMENTS

The growing markets in consumer goods and packaged pharmaceuticals drive the development of packaging equipment. Filling and sealing machines, also labelling and coding devices are important to ensure product safety throughout the supply chain.

To meet these needs, the industry has gradually introduced more automation and more sophisticated electronic controls.

In today's packaging production lines, the different stages are completed in minutes rather than in hours compared to years past.

In all types of packaging machinery – in all sectors of industry - each component must meet the strict requirements of the individual application.

This is to guarantee the continuity of production and the conformity of the packaged product to quality standards.

For many years, Carlo Gavazzi photoelectric, inductive and capacitive sensors have proven to be the best solution in applications for filling and checking.

In shrink wrapping applications, careful control of heating is essential for good results. Solid state relays are used to switch the heaters on and off in order to maintain the correct temperature.

The packaging industry also needs safety devices to guarantee the safety of the operators engaged in the work area, ensuring safe operation of the machines.

Carlo Gavazzi's comprehensive safety range includes safety light curtains and key switches that detect intrusions within the non-safe zone/s and shut down the machinery in a controlled manner via standard and/or configurable safety modules.

For all its products, Carlo Gavazzi offers easy installation, high precision and long term reliability.

# Packaging Machinery

## Filling



### Photoelectric sensors

PD30ET  
PD30C

### Photoelectric sensors

PA18  
PH18

### Inductive sensors

ICB12  
ICB18  
ICB30

### Ultrasonic sensors

UA18  
UA30

### Capacitive sensors

CA18  
CA30

### Conductive level probes

CLH  
CLD

Carlo Gavazzi offers a complete range of automation components for the packaging industry.

In a bottling line UA ultrasonic sensors are used to verify that the appropriate level of a product is in the container before it is sealed and shipped.

Ultrasonic sensors are also used to measure the level of ingredients – either liquid or solid – in a container. The continual analog output signal allows for better control of the process. The levels of solid material, such as ground coffee, coffee beans or flour, are accurately detected using photoelectric sensors.

The PA /PH 18 sensors come with a new mounting bracket which allows

fast mounting and space saving. Axial, radial and square versions are available. Important benefits are that objects do not hit the sensors as often and the conveyor can be cleaned much more easily.

For accurate control of the filling process, PD30 sensors provide an output signal

when the product is at the appropriate fill level.

The PD30 Stainless steel sensors are designed for wet as well as dry areas. The stainless steel housing and high-end plastic materials guarantee maximum resistance against IP68K and Ecolab cleaning processes.



# Inspection

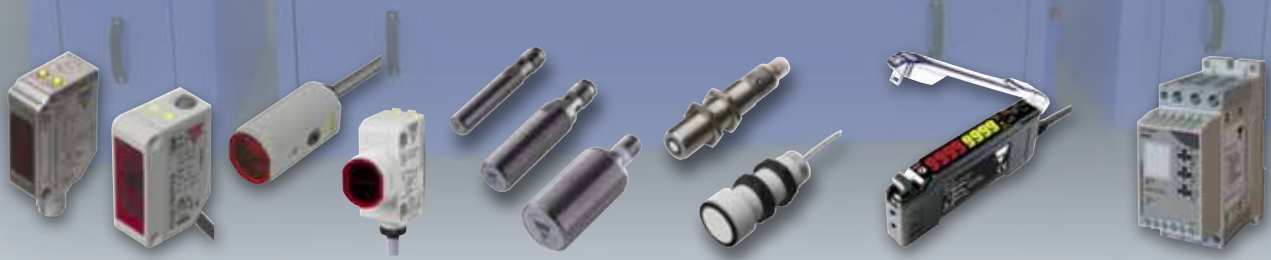
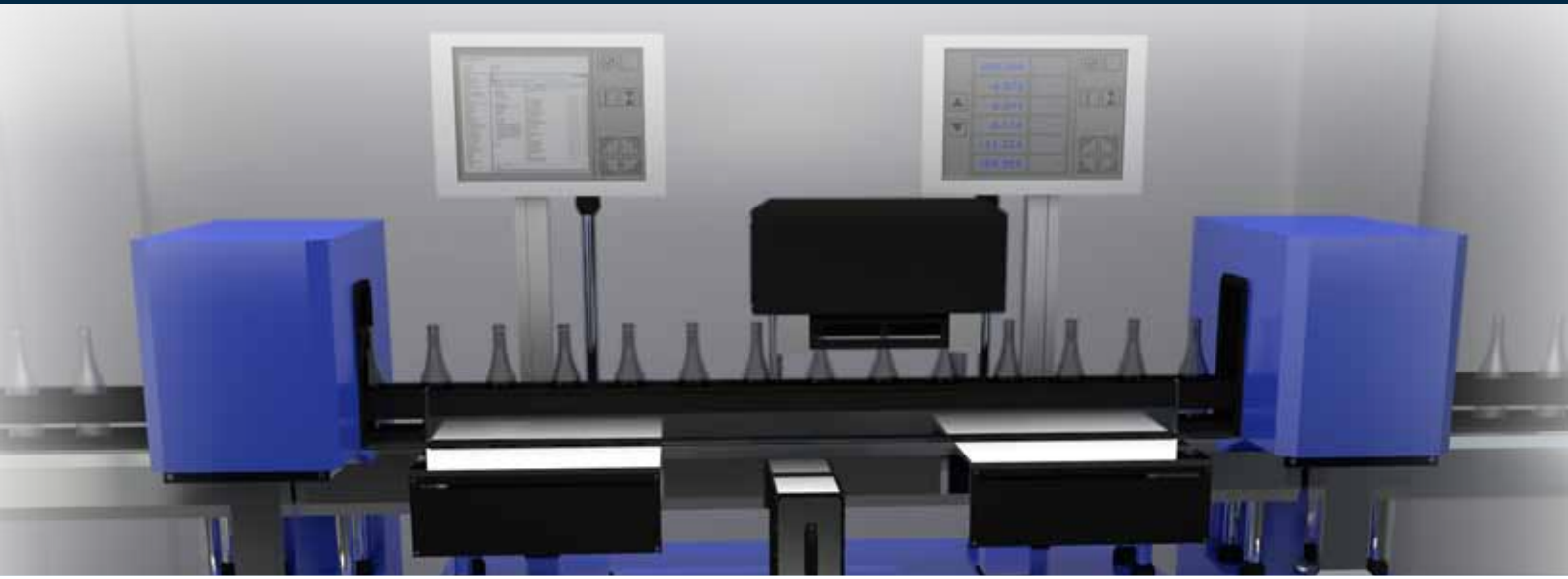

### Photoelectric sensors

PD30ET  
PD30C

### Photoelectric sensors

PH18  
PA18

### Inductive sensors

ICB12  
ICB18  
ICB30

### Ultrasonic sensors

UA18  
UA30

### Fiber optic amplifiers

FA1

### Soft starters

RSGD

Carlo Gavazzi products have many applications in the inspection-detection field. For bottling lines that have darker or less transparent bottles, PA18 through beam sensors can be used to detect the presence of the bottles. This family of products is from 40 % to 60 % smaller than existing housings.

The PD30 Stainless Steel (background suppression) sensors superiorly detects all colours on objects in the same distance from the sensor, and its durable design withstands daily cleaning processes. The specialised optics of the PD30CNG - combined with a reflector - are perfect for detecting clear bottles

on a conveyor.

In some confectionery applications, it is necessary to detect if a cake decoration is present or properly positioned. The PD30 diffuse sensor recognise the coloured decoration on top of the cake. Furthermore, the new fiber optic amplifier FA1 and the series of fiber optic cables FUR & FUT offer even more flexibility to the packaging market segments". To verify that a bottle cap is present on the bottle a FA1 fiber optic amplifier with a fiber optic cable and lens are positioned above the bottles and programmed to detect any reflection from the bottle cap.



# Packaging Machinery

## Wrapping and sealing

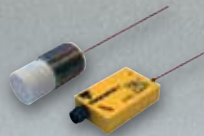
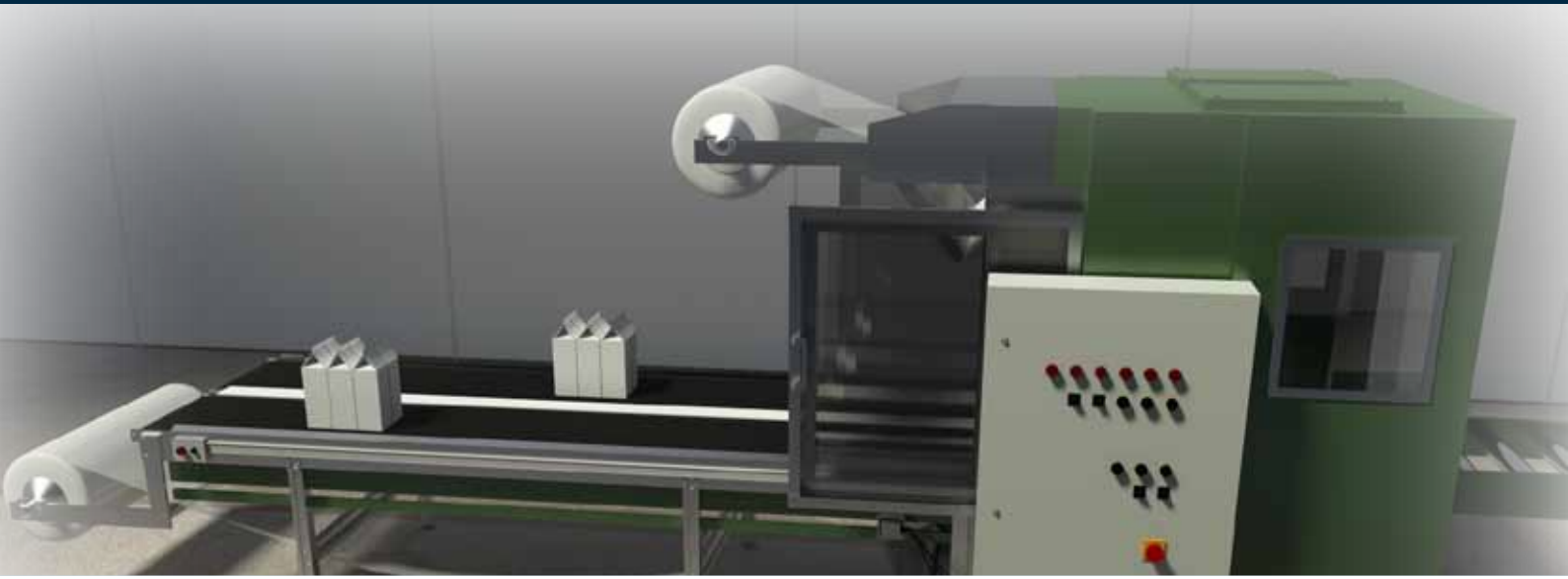

**Photoelectric sensors**

**Photoelectric sensors**

**Capacitive sensors**

**Solid state switches**

**Solid state switches**

**3-phase solid state contactors**

**PD112**

**PD30CN**

**ECH**

**RGS  
RGC  
RM**

**RGC1S  
RGS1S**

**RGC3A  
RGC2A**

Multiple bottles are bundled together and shrink-wrapped. Carlo Gavazzi solid state relays (RM or RG series) allow fast switching of heaters that enable accurate control of the process temperature thus maintaining an even shrink of the plastic wrap. Solid state solutions allow frequent switching without affecting the lifetime of the switch, unlike mechanical contactors. In order to verify that the shrink-wrap has been added, a PD30CNG clear object sensor is positioned to focus at the level of the bottle necks. If the shrink-wrap is present, the clear object sensor will have a continuous output as the package passes by. Diffuse reflective photoelectric sensors

with long detecting distance (PD112) detect goods on the pallet to ensure that wrapping is stopped at the required height. In hot-melt heating systems the high temperature ECH sensors have proven their capability and reliability. Other applications include automatic continuous processes of thermoforming, filling and sealing. The RG range offers a wide variety of solutions, starting from just solid state switching of heaters to more sophisticated solutions that apart from the switching function integrate monitoring features that are able to detect load and system malfunctions to guarantee a reliable thermal process.



# Labelling



## Fiber optic amplifiers

**FA1**

## Photoelectric sensors

**PC50**

## Photoelectric fork sensors

**PF80**

## Timers

**DAA51  
DMB51**



Once a container is filled, the next step is to apply the appropriate label. A fiber optic amplifier FA1 is used to detect the presence of a mark on a bottleneck label, which confirms that the bottle is in correct position for the main label to be applied. These sensors also detect the presence of security bands which are required on many bottles and containers. They recognise the difference between the security band and bottle cap. The FA1 is compact and highly intuitive for easy setup. It is equipped with two 4-digit LED displays for clear and concise reading. An adjustable signal level, selectable response time and different timer functions provide full

flexibility. Coupled with the robust and complete range of fiber optic cables FUR & FUT, this amplifier can be used in many applications. Precise control of labels, even small labels, is an important part of the packaging process. The surfaces of the labels are often reflective. The photoelectric proximity sensors provide the necessary sensitivity for maximum reliability. Detection of labels, marks and double sheets, as well as holes and edges, are typical applications for the PF80 fork sensor

# Packaging Machinery

Our expertise

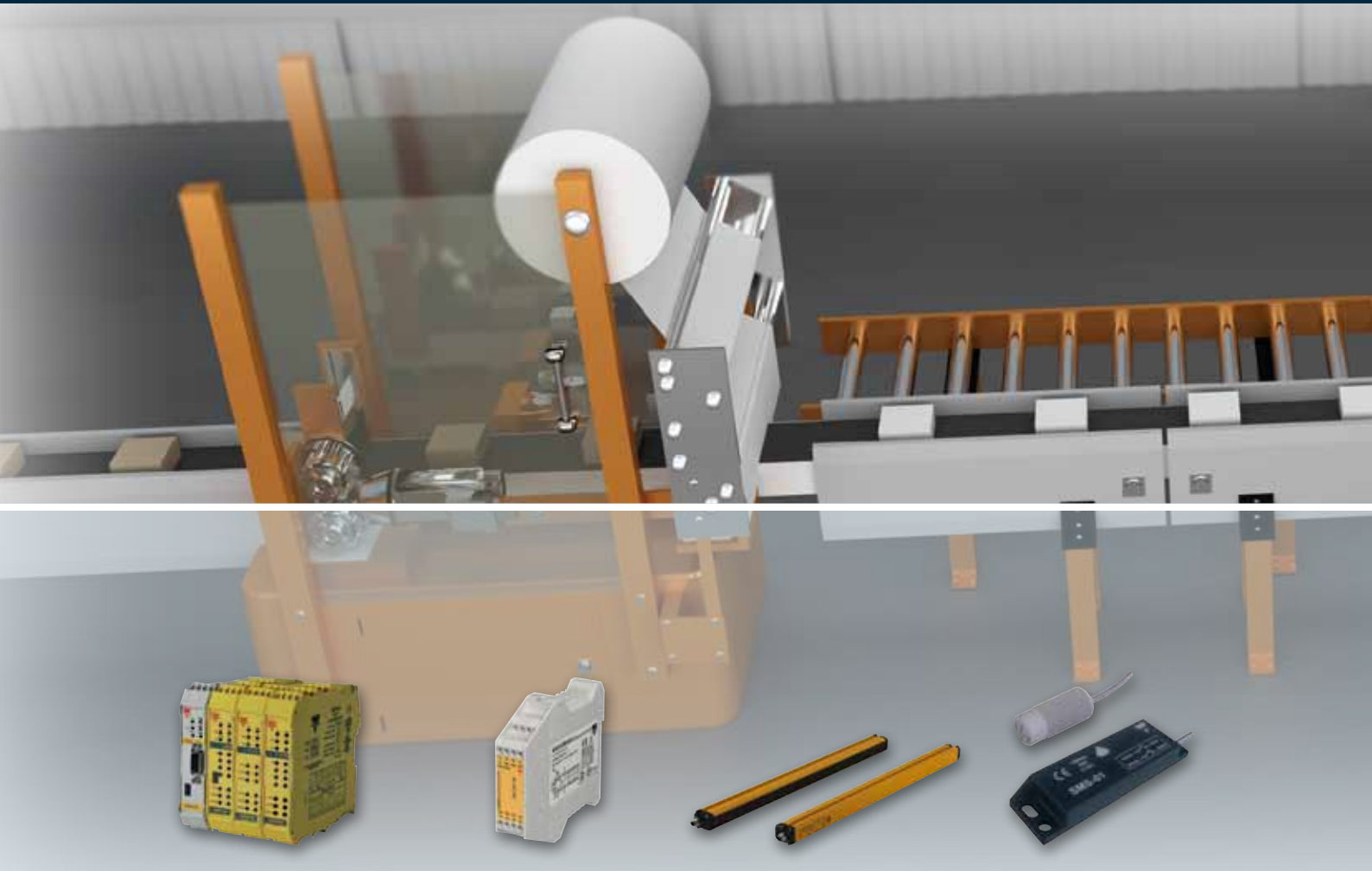

## Certus configurable safety modules

**CERTUS**

Carlo Gavazzi's safety devices are especially popular in the packaging machinery market segment. They must be able to prevent access to dangerous areas, until the machines are completely stopped. For example, the new CERTUS configurable safety module offers up to 128 inputs and 16 pairs of programmable solid state outputs in a compact modular system, managing and monitoring at the same time safety sensors and commands such as: safety light curtains, photocells, emergency stops, two-hand controls, mechanical switches, laser scanners, and safety mats. CERTUS is certified to the highest safety levels: SIL 3, SILCL 3, PL e and Cat.4, and its advantages to the packaging industry are endless. Safety light curtains, types 2 and 4, with the

## Safety modules

**NES13  
NSO13  
NLG13**

muting function provide easy access to load and unload optimising productivity output. The type 4 safety light curtains also feature the EDM function to control the reliability of external devices. The safety modules (used with safety light curtains, safety photo sensors, emergency stop buttons or safety magnetic switches) close the safety control loop.

## Safety light curtains

**SC4  
SC2**

## Safety magnetic switches

**SMS  
CLS**

Our safety magnetic sensors (SMS, CLS) are particularly addressed to the safety gates that allow the entry to machines with dangerous movements. All of this makes Carlo Gavazzi the clear choice for safety components in your packaging machinery applications.





# Safety devices and energy efficiency

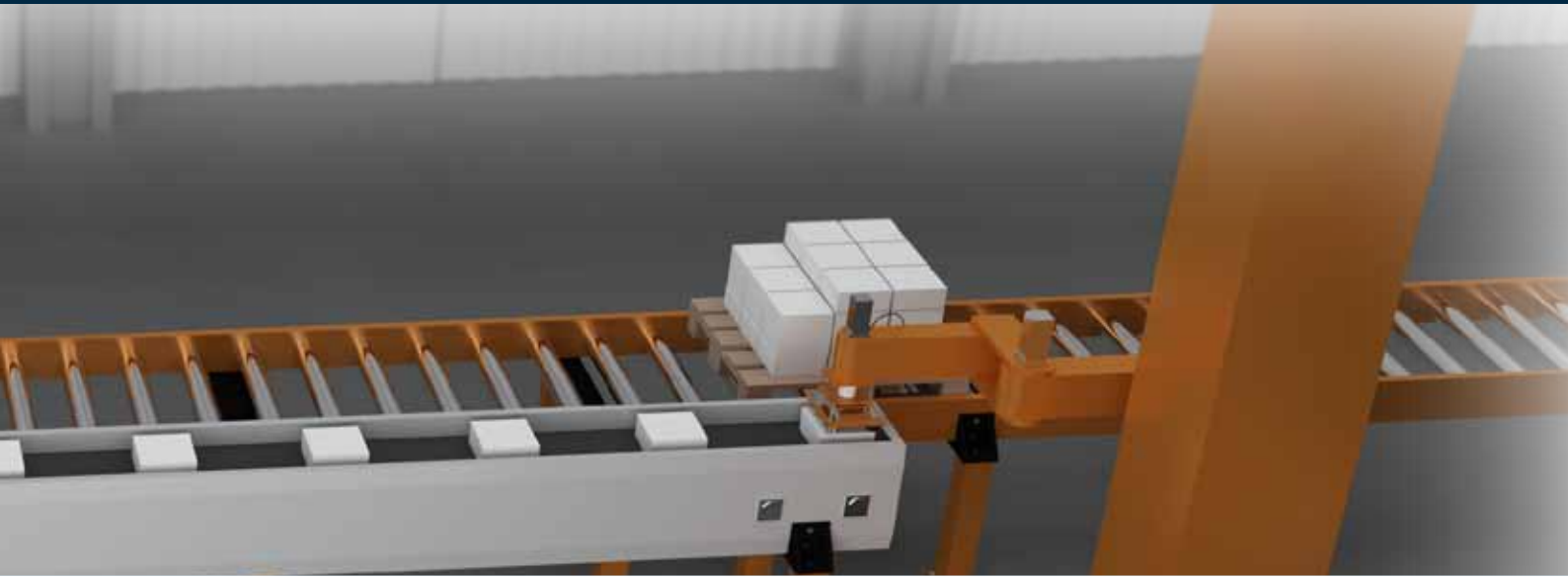

## Energy analysers

**EM210**

## Energy transducers

**ET112  
ET340**

## Monitoring relays

**DPB01  
DPA01  
DIB01**

## Switching power supplies

**SPD  
SPPC**

## DC UPS

**SPUBC  
SPUC**

Carlo Gavazzi offers a vast array of products to improve energy efficiency and to ensure the monitoring of entire processes - all from one source.

Energy management components, for instance, provide vital information for operators to identify consumption trends and take corrective action.

EM210 energy analysers or the ET energy transducers can monitor all the main parameters of an electric line or load.

Monitoring relays DPB01/PP01 or DPB71 monitor phase sequence-loss and over-under voltage of the mains to set up a check system.

Carlo Gavazzi timers - available in four different housings (standard DIN-rail, Plug-in, 48x48 and MiniD housing) - provide correct, reliable solutions for every application.

The SPUC and the SPUBC modules guarantee power supply and electrical continuity in case of mains failure in applications where it is mandatory to have a DC supply at all times, or for a certain time after mains shutdown.



# Packaging Machinery

## Our product range

### Photoelectric sensors



#### PA18 / PH18

- Standard M18 cylindrical housing
- Power supply: 10 to 30 VDC
- Separate models available for NPN or PNP outputs
- Range: 1 m (Axial), 0.8 m (Radial)
- Sensitivity adjustment by potentiometer
- Approvals/Marks: CE - cULus

#### MAIN FEATURES

- Complying with the requirements of ECOLAB, PI67, IP69K
- Approved according to UL508
- Diagnostic LED indication (Green and Yellow LED)
- Short-circuit, reverse polarity and overload protection

### Photoelectric sensors



#### PD30C

- World standard housing style
- Power supply: 10 to 30 VDC
- NPN or PNP transistor output
- Connection cable or built in M8 connector
- Sensitivity adjustment by Teach-in or by potentiometer
- Approvals/Marks: CE - UL 508

#### MAIN FEATURES

- Background suppression version, with accurate detection
- Long detecting distances
- Protection: reverse polarity, short circuit and transients

### Photoelectric sensors



#### PD30ET

- World standard housing style 11 x 31.5 x 21 mm
- Supply voltage: DC 4-wire
- Sensing distance: < 15 m
- Output: NPN/PNP NO+NC
- Sensor types: D, B, R, P and T
- Connectivity: Cable or M8 connectors
- Approvals/Marks: CE - cULus - ECOLAB

#### MAIN FEATURES

- Stainless Steel housing AISI 316L
- Resistant to high-pressure washdown, aggressive cleaning agents.
- IP67, IP68, IP69K, NEMA type 1, 2, 4, 4x, 5, 6, 6P
- Protection: reverse polarity, short circuit and transients

### Photoelectric sensors



#### PC50

- Dimensions: 17 x 50 x 50 mm
- Sensing distance up to 20 m
- Modulated infrared light
- Make and break switching function selectable
- Cable and plug version
- Approvals/Marks: CE - UL - CSA

#### MAIN FEATURES

- Adjustable sensitivity
- High EMC immunity
- Protection: reverse polarity, short circuit and transients

### Photoelectric sensors



#### PD112

- Dimensions: 25 x 45 x 112 mm
- Long range background suppression (BGS) sensor
- Power supply receiver: 10 to 30 VDC
- NPN and PNP NO or NC output
- Emitter with Mute Input for testing sensor function
- 2.5 m sensing distance

#### MAIN FEATURES

- Light beam approved to Safety Category 2
- UL325, UL508, EN12445, EN12453, EN12978
- Long detection range on black objects

### Fiber optic amplifiers



#### FA1

- 2 X 4 digit LED display for signal and threshold level
- Easy setup 3 way adjustment switch
- Selectable response time, timing delay functions
- 100mA NPN PNP NO NC Switching

#### MAIN FEATURES

- Varieties of through beam and reflective fiber optic cable
- Ø 0.25, 0.5 or 1.0 mm inner fiber diameter for different applications
- Extra overmoulding on fiber units for better fiber curvature protection

### Photoelectric fork sensors



#### PF80

- Dimensions: 12 x 37.5 x 80 mm. Slot width 3 mm
- Teach-In: push button or by wire
- Rated operational voltage 10 - 30 VDC
- Aluminium housing
- Approvals/ Marks: CE

#### MAIN FEATURES

- High speed of detection
- Detection of transparent material
- Detection of labels, marks and double sheets

### Inductive sensors









#### ICB12 / ICB18 / ICB30

- M12, M18 and M30 Nickel-brass housing in short or long barrel lengths
- Standard, double and triple distance sensing ranges
- Output functions: NO or NC, NPN or PNP
- Two metres oil resistant PVC cable or M12 plug version
- Protection: reverse polarity, short circuit, transients

#### MAIN FEATURES

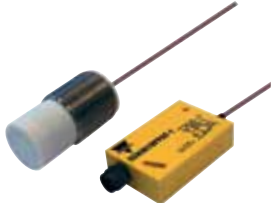
- High precision and reliability thanks to the microprocessor technology
- Short-circuit and overload LED indication
- Laser engraved information on the front cap, permanently legible

# Our product range

Conductive level controllers / probes	Ultrasonic sensors	Capacitive sensors	Capacitive sensors
 <p><b>CLD / CLH</b></p> <ul style="list-style-type: none"> <li>• 17.5mm slim housing, 22.5mm &amp; 35 mm housing available</li> <li>• Multiple filling and emptying functions</li> <li>• 24-240 VAC/DC (CLD2EB1BU24)/ 24 VDC, 115 VAC, 230 VAC</li> <li>• Flexible modular probes up to 5 electrodes (CLH5)</li> <li>• Extendible probes for longer length</li> </ul> <p><b>MAIN FEATURES</b></p> <ul style="list-style-type: none"> <li>• Wide operational supply voltage range</li> <li>• Slim compact housing</li> <li>• Wide sensitivity adjustment 250 Ω to 500 KΩ</li> <li>• Cascading amplifiers for more levels (CLP2FA)</li> </ul>	 <ul style="list-style-type: none"> <li>• Dimensions: M18, M30</li> <li>• Ultrasonic sensors with integrated amplifier providing a digital and/or analog output and integrated amplifier</li> <li>• Housing material: plastic and stainless steel</li> <li>• Sensing distance up to 6 m</li> <li>• Approvals/Marks: CE - cULus - CSA</li> </ul> <p><b>MAIN FEATURES</b></p> <ul style="list-style-type: none"> <li>• Excellent EMC performance and precision</li> <li>• Detects clear, transparent and shiny targets, solid objects, liquid or granules.</li> <li>• Protection: short circuit, transient and reverse polarity</li> </ul>	 <p><b>CA18 / CA30</b></p> <ul style="list-style-type: none"> <li>• 4<sup>th</sup> generation Tripleshield™ technology</li> <li>• Dimensions: M18 / M30</li> <li>• Plastic housings DC versions</li> <li>• Sensing distance up to 30 mm</li> <li>• Approvals/Marks: CE - cULus</li> </ul> <p><b>MAIN FEATURES</b></p> <ul style="list-style-type: none"> <li>• Highest EMC immunity</li> <li>• ESD ratings up to 40 kV</li> <li>• Sensing face temperature up to 120°C</li> <li>• Best immunity towards Inverters</li> </ul>	 <p><b>ECH</b></p> <ul style="list-style-type: none"> <li>• Sensor diameter: M30, teflon and stainless steel</li> <li>• Adjustable sensing distance: 4 to 15 mm, factory set for 10 mm</li> <li>• Output: transistor NPN or PNP, make &amp; break switching</li> <li>• Power supply: 10 to 40 VDC</li> </ul> <p><b>MAIN FEATURES</b></p> <ul style="list-style-type: none"> <li>• Provided with a separate teflon sensor head in M30 for temperature application within the range of -196°C and +180°C</li> <li>• Protection: reverse polarity, short-circuit, transients</li> </ul>
<p><b>PCB mount solid state relays</b></p>  <p><b>RP1</b></p> <ul style="list-style-type: none"> <li>• Dimensions: 25.4 x 43 x 10.5 mm</li> <li>• Operational voltage range: 24-480 VAC</li> <li>• Rated operational current: 3, 5, 5.5, 10 AAC</li> <li>• Control input ranges: 4-32 VDC, 16-32 VAC</li> <li>• Approvals/Marks: CE - cURus - VDE [RP1...3,5,6]</li> </ul> <p><b>MAIN FEATURES</b></p> <ul style="list-style-type: none"> <li>• Zero cross or random switching</li> <li>• 4 kV isolation between input &amp; output</li> <li>• Accessories for DIN mount option available</li> </ul>	<p><b>1-phase solid state relays</b></p>  <p><b>RM1.. / RAM1..</b></p> <ul style="list-style-type: none"> <li>• Dimensions: 58.2 x 44.8 x 28.8 mm, panel mount</li> <li>• Rated operational voltage: up to 660 VAC</li> <li>• Rated operational current: 25, 50, 75, 100, 125 AAC</li> <li>• Control input ranges: 4-32 VDC, 20-280 VAC</li> <li>• Approvals/Marks: CE - cURus - CSA - CCC - VDE [RAM1A..]</li> </ul> <p><b>MAIN FEATURES</b></p> <ul style="list-style-type: none"> <li>• Zero cross or random switching</li> <li>• Low noise emission - EN55011 class B conformance [RAM1A..]</li> <li>• Integrated over-voltage protection [RM1]</li> </ul>	<p><b>1-phase solid state switches</b></p>  <p><b>RGS1.. / RGC1..</b></p> <ul style="list-style-type: none"> <li>• Product width: 17.5 mm up to 70 mm, DIN or panel mount</li> <li>• Ratings: up to 660 VAC, 90 AAC, 18000 A<sup>2</sup>s</li> <li>• Integrated output overvoltage protection</li> <li>• Control input ranges: 4-32 VDC, 20-275 VAC (24-190 VDC)</li> <li>• Approvals/Marks: CE - cULus (RGC) - cURus (RGS) - CSA (RGS) - VDE - GL (RGC up to 30 AAC)</li> </ul> <p><b>MAIN FEATURES</b></p> <ul style="list-style-type: none"> <li>• Integrated heatsink (RGC1..), without heatsink (RGS1..)</li> <li>• 100 kA short circuit current rating</li> <li>• Optional overtemperature protection</li> </ul>	<p><b>1-ph solid state switches with current monitoring</b></p>  <p><b>RGS1S.. / RGC1S..</b></p> <ul style="list-style-type: none"> <li>• Product width: 22.5 mm up to 70 mm, DIN or panel mount</li> <li>• Ratings: up to 660 VAC, 90 AAC, 18000 A<sup>2</sup>s</li> <li>• Integrated output overvoltage protection</li> <li>• Control input range: 4-32 VDC</li> <li>• Approvals/Marks: CE - cULus [RGC1S] - cURus [RGS1S] - CSA [RGS1S]</li> </ul> <p><b>MAIN FEATURES</b></p> <ul style="list-style-type: none"> <li>• Partial load failure detection (1/6)</li> <li>• Monitoring for SSR and load circuit malfunction</li> <li>• TEACH by local push button or remote signal</li> </ul>

# Packaging Machinery

## Our product range

### 3-phase solid state contactors



#### RGC3A.. / RGC2A..

- Product width: up to 70 mm, DIN-rail mounting
- Ratings: up to 660 VAC 75 AAC/pole [RGC2], 65 AAC/pole [RGC3] @ 40°C
- Motor ratings up to 11 kW @ 400 VAC, 25 HP @ 600 VAC
- Control input range: 5-32 VDC, 20-275 VAC (24-190 VDC)
- Approvals/Marks: CE - cULus

#### MAIN FEATURES

- 3-phase; 2-pole [RGC2] or 3-pole [RGC3] switching
- Monitoring for SSR and load circuit malfunction [RGC..M]
- 100 kA short circuit current rating

### Soft starters



#### RSGD

- Motor rating: up to 22 kW in 45 mm
- Ramp up time: 1 - 20 sec
- Multi-voltage operation: RSGD40: 220-400 VAC, RSGD60: 220-600 VAC
- Wide control voltage range: Option E: 110-400 VAC, option F: 24 VAC/DC, option G: 100-240 VAC (RSGD60 only)

#### MAIN FEATURES

- Easy to use and setup
- Current balancing algorithm
- Auxiliary relays for top of ramp and alarms
- Internally bypassed

### Variable frequency drives



#### RVLF

- Compact dimensions: 2 physical frame sizes
- VF control and auto-torque compensation
- Drive voltage rating: 200-240 VAC or 380-480 VAC
- Drive KW rating: 0.2 KW - 2.2 KW, (0.25 HP - 3.0 HP)
- Approvals/Marks: CE - IEC - cULus

#### MAIN FEATURES

- Ease of use, minimal settings
- PID control & torque boost capability
- Less disturbance with built-in EMI filter

### Safety magnetic sensors and units



#### SMS / CLS

- Rectangular or cylindrical housing
- Several output configurations available
- Up to 175 VDC switching voltage
- 350 mA maximum output
- Up to 10 W switching power
- IP67 protection

#### MAIN FEATURES

- Rugged plastic or stainless steel housing
- Operating temperature: -25°C to 70°C
- Cable output or M12 pigtail connection
- Cylindrical or rectangular safety magnets

### CERTUS configurable safety modules



#### CMM

- 4 non-safety test outputs for sensor monitoring
- 2 non-safety programmable digital signal outputs
- 2 non-safety inputs for Start / Restart interlock and EDM
- LOG file with 5 configuration modifications
- Connection with other exp. units via rear bus

#### MAIN FEATURES

- Also usable as a stand-alone device, able to control any other expansion unit
- 8 safety digital inputs
- 2 safety OSSD pairs (400 mA Output)
- Certified to the highest safety levels: SIL 3, SILCL 3, Ple, Cat.4, CE, TU, cULus

### CERTUS configurable I/O expansion modules



#### C I/O

- Wide range of Input/Output, Input only or Output only (both OSSD and standard relay) expansion units to serve different application requirements
- Models offer a variety of non-safety Inputs/Outputs such as: inputs for Start/Restart interlock and EDM, test outputs

#### MAIN FEATURES

- The models offer eight combinations:
  - 8 Inputs 2 Outputs; 12 Inputs 8 test Outputs
  - 8 Inputs, 16 Inputs,
  - 2 OSSD, 4 OSSD
  - 2 relay Outputs, 4 relay Outputs

### CERTUS data and diagn. modules + bus transfer



#### DDC + CBT

- DDC: Allows communication with most common industrial fieldbus systems:
  - C PFBUS - Profibus DP, - C DNET - DeviceNET
  - C CAN - CANOpen, - C EIP - Ethernet IP
  - C ECAT - EtherCAT, - C PFNET - PROFINET
  - C OMWS - Universal Serial Bus
- Bus Transfer: Interface module allowing the connection of remote expansions via bus

#### MAIN FEATURES

- Bus transfer: up to 100 m for each connection. Maximum 5 CBT expansions. Ideal solution for the interconnection of the safety functions of several machines in a production line

### CERTUS Speed monitoring modules



#### CES series

- Expansion units to monitor speed (Ple):
  - Zero speed; - Max speed, - Speed range
  - Motion direction: rotation / translation
- RJ45 for encoder connections and terminal blocks for connection of proximity (up to 2 proximity switches per module)
- Inputs frequency: Encoder up to 500 KHz (300 KHz for HTL);

#### MAIN FEATURES

- The modules allow to configure up to 4 speed thresholds for each logic output (axis).
- Each module integrates two logic outputs configurable via the MSD and is therefore capable to control up to two independent axes.

# Our product range

## Safety modules



### NES13 / NSO13 / NLG13

- Safety modules for emergency stop and safety gate (NES13/NSO13) and light curtains (NLG13)
- 2NO / 3NO safety outputs
- IP40 protection for housing and IP20 protection for terminals
- Safety category 4
- Approvals/Marks: CE - UL - TUV - cULus

#### MAIN FEATURES

- < 30 ms response time
- Safety Integrity Level SILcl:3 in according with IEC 62061
- Performance Level PLr:e in according with ISO 13849-1

## Safety light curtains



### SC2 / SC4

- Lengths from 300 to 1500 mm for type 2
- Resolution: finger, hand
- Lengths from 150 to 1650 mm for type 4
- Resolution: hand, body
- Dimensions: 36.9 x 32.3 mm,
- Approvals/Marks: CE - cULus

#### MAIN FEATURES

- Selectable Manual/Automatic Restart, EDM and Anti-interference
- 24 VDC supply with two PNP transistor outputs
- IEC-61496-2 environment light rejection

## 3-phase monitoring relays



### DPA01

- Dimensions: 81 x 22.5 x 99.5 mm DIN-rail housing
- 3-phase monitoring relay for phase sequence and phase loss
- Supply range from 208 to 690 VAC covered by two multi-voltage relays
- Approvals/Marks: UL - CCC - CSA

#### MAIN FEATURES

- Detects when all phases are present and have the correct sequence
- LED indication for relay and power supply ON

## 3-phase monitoring relays



### DPB01

- Dimensions: 81 x 22.5 x 99.5 mm DIN-rail housing
- TRMS 3-phase over and under voltage, phase sequence and phase loss monitoring relays
- 3 phase AC (own power supply); regenerated voltage
- Power supply 208 to 480 VAC
- Approvals/Marks: UL - CSA

#### MAIN FEATURES

- Selection of measuring range by DIP-switches
- LED indication for relay, alarm and power supply ON

## 3-phase monitoring relays



### DWA01

- Dimensions: 83 x 22.5 x 99.5 mm DIN-rail housing
- Cos  $\Phi$  monitoring relays
- 3-phase AC (own power supply)
- Power supply from 208 to 240 VAC or from 380 to 480 VAC
- Approvals/Marks: UL - CSA

#### MAIN FEATURES

- Detects any potentially dangerous change of the cos  $\Phi$
- Direct current connection or by CT
- Easy setup

## Current monitoring relays



### DIA 53

- Dimensions: 81 x 17.5 x 67.2 mm DIN-rail housing with 12 mm hole for current measurement
- Current monitoring relay with built-in current transformer
- 20, 50 or 100 A full scale
- Self powered
- Approvals/Marks: UL - CSA - CCC

#### MAIN FEATURES

- 2 wire connection
- Knob adjustable setpoint
- Integrated solid state NPN PNP output

## Current monitoring relays and Current transformers



### DIB01 / A82

- Dimensions: 81 x 22.5 x 99.5 mm DIN-rail housing
- TRMS AC/DC over or under current monitoring relay
- Direct measuring or through current transformer (A82)
- A82: true RMS AC current metering transformer for 25, 50, 100, 250 or 500 AAC
- Approvals/Marks: UL - CSA

#### MAIN FEATURES

- Programmable latching or inhibit at set level
- LED indication for relay, alarm and power supply ON
- A82: easy interface to PLC or setpoint relays

## Motor thermistor relays



### DTA71 / DTA72

- 35 mm Mini-DIN housing
- Motor thermistor relay
- PTC Open and PTC Short detection
- Universal power supply from 24 V to 240 VAC/DC
- Approvals/Marks: UL - CE approved

#### MAIN FEATURES

- Multicolour LED with alarm discrimination
- Auto or manual, local or remote reset, test function (DTA72)
- Ready for reset function (DTA72)

# Packaging Machinery

## Our product range

### Energy analysers



#### EM210

- 3-phase energy meters with CT connection
- Solid or split-core 5A CT
- Dimensions: 4 DIN modules or 72x72 housing
- Class 1 (kWh) acc. to EN62053-1
- Class B (kWh) acc. to EN50470-3
- Pulse open collector or serial RS485 output

#### MAIN FEATURES

- Very compact and space saving meter
- Can be installed both on DIN-rail or on the panel
- MID annex D certification available

### 1 and 3-phase energy transducers



#### ET112 / ET340

- 2 DIN size; DIN-rail mounting (ET112)
- 3 DIN size; DIN-rail mounting (ET340)
- Measurement of voltage, current, power, power factor and frequency
- Bi-directional energy metering, 2 tariffs, cl. 1 (EN62053-1)
- Measuring inputs: 115/230 VAC, 100 A (ET112), single phase
- Measuring inputs: 208 to 400 V<sub>LL</sub> VAC, 65 A (ET340), 3-phase

#### MAIN FEATURES

- Self-powered
- RS485 Modbus port (screw, 2x RJ45)
- Optical port
- Sealable terminal covers
- CE

### Timers



#### DAA51 / DMB51

- Dimensions: 81 x 17.5 x 67.2 mm DIN-rail housing
- Delay on operate function (DAA), multifunction (DMB)
- Combined AC and DC power supply
- Repeatability: < 0.2%
- Approvals/Marks: UL - CSA - RINA approved

#### MAIN FEATURES

- Delay on operate/release; interval (manual/automatic start);
- Double interval; symmetrical recycler (ON or OFF first)
- Timing range from 0.1s to 100h

### DIN rail switch mode power supplies



#### SPD

- DIN rail mounting
- 1-phase (5-480 W), 2-phase (100 W), 3-phase (120-960 W)
- Rated input voltage: 85-264 VAC (1-phase), 380-575 VAC (2-phase), 340-575 VAC / 480-820 VDC (3-phase)
- Approvals/Marks: CE - TÜV - cULus - UL1310 Class 2 (<92W), ISA12.12.1 Class 1, Div 2

#### MAIN FEATURES

- Power Factor Correction (PFC)
- Parallel connection
- DC OK output

### Metal enclosed power supplies



#### SPPC

- Output power from 25 W to 800 W
- Input 110/240 VAC single phase
- Short circuit, overload and overvoltage protection
- PFC function available >75 W
- Approvals/Marks: CE - UL

#### MAIN FEATURES

- Adjustable output +/- 10%
- Compact dimensions
- Wide operating temperature range up to 70°C

### DC UPS controllers



#### SPUC

- Up to 30 A UPS controller
- 12 V and 24 V versions
- Outputs for Device OK, Battery OK and battery Low.
- DIN rail battery accessory available up to 7.2 A/h
- Approvals/Marks: CE - UL

#### MAIN FEATURES

- To be used in addition to 12 or 24 V power supply
- Front 30 A replaceable fuse
- Plug and play: no settings needed

### DC UPS battery chargers



#### SPUBC

- Power supply, UPS and battery charger "All in one"
- 24 VDC 5 A output
- Power boost up to 2 times rated output, permanent.
- Built in battery diagnosis
- Approvals/Marks: CE - UL

#### MAIN FEATURES

- Power supply independent from charger.
- Remote indication for battery operation and battery low
- "Start from battery" and "Empty battery charging" features

### Touch screen/Dataloggers



#### BTM-T4-24 / BTM-T7-24

- 4" / 7" colour display
- Easy setup of graphic pages and functions with the powerful software Wizard
- Activation of internet links through touch buttons
- Support viewing from IP cameras

#### MAIN FEATURES

- Ethernet connection
- Wide screen display, 64 K colours
- USB port, SD memory, Modbus RTU serial port

## OUR SALES NETWORK IN EUROPE

### AUSTRIA

Carlo Gavazzi GmbH  
Ketzergasse 374,  
A-1230 Wien  
Tel: +43 1 888 4112  
Fax: +43 1 889 10 53  
office@carlogavazzi.at

### FRANCE

Carlo Gavazzi Sarl  
Zac de Paris Nord II, 69, rue de la Belle Etoile,  
F-95956 Roissy CDG Cedex  
Tel: +33 1 49 38 98 60  
Fax: +33 1 48 63 27 43  
french.team@carlogavazzi.fr

### ITALY

Carlo Gavazzi SpA  
Via Milano 13,  
I-20020 Lainate  
Tel: +39 02 931 761  
Fax: +39 02 931 763 01  
info@gavazziacbu.it

### SPAIN

Carlo Gavazzi SA  
Avda. Iparragirre, 80-82,  
E-48940 Leioa (Bizkaia)  
Tel: +34 94 480 4037  
Fax: +34 94 431 6081  
gavazzi@gavazzi.es

### BELGIUM

Carlo Gavazzi NV/SA  
Mechelsesteenweg 311,  
B-1800 Vilvoorde  
Tel: +32 2 257 4120  
Fax: +32 2 257 41 25  
sales@carlogavazzi.be

### GERMANY

Carlo Gavazzi GmbH  
Pfnorstr. 10-14  
D-64293 Darmstadt  
Tel: +49 6151 81000  
Fax: +49 6151 81 00 40  
info@gavazzi.de

### NETHERLANDS

Carlo Gavazzi BV  
Wijkermeerweg 23,  
NL-1948 NT Beverwijk  
Tel: +31 251 22 9345  
Fax: +31 251 22 60 55  
info@carlogavazzi.nl

### SWEDEN

Carlo Gavazzi AB  
V:a Kyrkogatan 1,  
S-652 24 Karlstad  
Tel: +46 54 85 1125  
Fax: +46 54 85 11 77  
info@carlogavazzi.se

### DENMARK

Carlo Gavazzi Handel A/S  
Over Hadstenvej 40,  
DK-8370 Hadsten  
Tel: +45 89 60 6100  
Fax: +45 86 98 15 30  
handel@gavazzi.dk

### GREAT BRITAIN

Carlo Gavazzi UK Ltd  
4.4 Frimley Business Park,  
Frimley, Camberley, Surrey GU16 7SG  
Tel: +44 1 276 854 110  
Fax: +44 1 276 682 140  
sales@carlogavazzi.co.uk

### NORWAY

Carlo Gavazzi AS  
Melkeveien 13,  
N-3919 Porsgrunn  
Tel: +47 35 93 0800  
Fax: +47 35 93 08 01  
post@gavazzi.no

### SWITZERLAND

Carlo Gavazzi AG  
Verkauf Schweiz/Vente Suisse  
Sumpfstrasse 3,  
CH-6312 Steinhausen  
Tel: +41 41 747 4535  
Fax: +41 41 740 45 40  
info@carlogavazzi.ch

### FINLAND

Carlo Gavazzi OY AB  
Petaksentie 2-4,  
FI-00630 Helsinki  
Tel: +358 9 756 2000  
Fax: +358 9 756 20010  
myynti@gavazzi.fi

### PORTUGAL

Carlo Gavazzi Lda  
Rua dos Jerónimos 38-B,  
P-1400-212 Lisboa  
Tel: +351 21 361 7060  
Fax: +351 21 362 13 73  
carlogavazzi@carlogavazzi.pt

## OUR SALES NETWORK IN THE AMERICAS

### USA

Carlo Gavazzi Inc.  
750 Hastings Lane,  
Buffalo Grove, IL 60089, USA  
Tel: +1 847 465 6100  
Fax: +1 847 465 7373  
sales@carlogavazzi.com

### CANADA

Carlo Gavazzi Inc.  
2660 Meadowvale Boulevard,  
Mississauga, ON L5N 6M6, Canada  
Tel: +1 905 542 0979  
Fax: +1 905 542 22 48  
gavazzi@carlogavazzi.com

### MEXICO

Carlo Gavazzi Mexico S.A. de C.V.  
Calle La Montaña no. 28, Fracc. Los Pastores  
Nauclan de Juárez, EDOMEX CP 53340  
Tel & Fax: +52.55.5373.7042  
mexicosales@carlogavazzi.com

### BRAZIL

Carlo Gavazzi Automação Ltda. Av.  
Francisco Matarazzo, 1752  
Conj 2108 - Barra Funda - São Paulo/SP  
Tel: +55 11 3052 0832  
Fax: +55 11 3057 1753  
info@carlogavazzi.com.br

## OUR SALES NETWORK IN ASIA AND PACIFIC

### SINGAPORE

Carlo Gavazzi Automation Singapore Pte. Ltd.  
61 Tai Seng Avenue  
#05-06 UE Print Media Hub  
Singapore 534167  
Tel: +65 67 466 990  
Fax: +65 67 461 980  
info@carlogavazzi.com.sg

### MALAYSIA

Carlo Gavazzi Automation (M) SDN. BHD.  
D12-06-G, Block D12,  
Pusat Perdagangan Dana 1,  
Jalan PJU 1A/46, 47301 Petaling Jaya,  
Selangor, Malaysia.  
Tel: +60 3 7842 7299  
Fax: +60 3 7842 7399  
sales@gavazzi-asia.com

### CHINA

Carlo Gavazzi Automation  
(China) Co. Ltd.  
Unit 2308, 23/F.,  
News Building, Block 1, 1002  
Middle Shennan Zhong Road,  
Shenzhen, China  
Tel: +86 755 83699500  
Fax: +86 755 83699300  
sales@carlogavazzi.cn

### HONG KONG

Carlo Gavazzi Automation  
Hong Kong Ltd.  
Unit 3 12/F Crown Industrial Bldg.,  
106 How Ming St., Kwun Tong,  
Kowloon, Hong Kong  
Tel: +852 23041228  
Fax: +852 23443689

## OUR COMPETENCE CENTRES AND PRODUCTION SITES

### DENMARK

Carlo Gavazzi Industri A/S  
Hadsten

### MALTA

Carlo Gavazzi Ltd  
Zejtun

### ITALY

Carlo Gavazzi Controls SpA  
Belluno

### LITHUANIA

Uab Carlo Gavazzi Industri Kaunas  
Kaunas

### CHINA

Carlo Gavazzi Automation (Kunshan) Co., Ltd.  
Kunshan

## HEADQUARTERS

Carlo Gavazzi Automation SpA  
Via Milano, 13  
I-20020 - Lainate (MI) - ITALY  
Tel: +39 02 931 761  
info@gavazziautomation.com



**CARLO GAVAZZI**  
Automation Components

*Energy to Components!*

[www.gavazziautomation.com](http://www.gavazziautomation.com)

