PMC-SIO4AR-SYNC

User's Manual

**QUAD CHANNEL SYNCHRONOUS
SERIAL TO PARALLEL CONTROLLER
WITH DEEP TRANSMIT AND RECEIVE FIFOS**

PMC REAR I/O INTERFACE

***** NOT RECOMMENDED FOR NEW DESIGNS *****
***** See PMC66-SIO4BXR-SYNC for New 66MHz PCI Interface*****

General Standards Corporation
8302A Whitesburg Drive
Huntsville, AL 35802
Phone: (256) 880-8787
Fax: (256) 880-8788
URL: www.generalstandards.com
E-mail: techsupport@generalstandards.com

Revision D

PMC-SIO4AR Documentation History

1. Rev A - May 2003 – Original rev from PMC-SIO4AR manual.
2. Rev B – July 2003 – Fixed programmable clock documentation and appendix A table values
3. Rev C – March 2004 – Fixed errors in bit definitions for some registers/ fixed TOC
4. Rev D – March 2004 – Product moved to Legacy Status

PREFACE

Copyright © 2012 General Standards Corporation

Additional copies of this manual or other **General Standards Corporation** literature may be obtained from:

General Standards Corporation
8302A Whitesburg Drive
Huntsville, Alabama 35802
Telephone: (256) 880-8787
Fax: (256) 880-8788
URL: www.generalstandards.com

The information in this document is subject to change without notice.

General Standards Corporation makes no warranty of any kind with regard to this material, including, but not limited to, the implied warranties of merchantability and fitness for a particular purpose. Although extensive editing and reviews are performed before release to ECO control, **General Standards Corporation** assumes no responsibility for any errors that may exist in this document. No commitment is made to update or keep current the information contained in this document.

General Standards Corporation does not assume any liability arising out of the application or use of any product or circuit described herein, nor is any license conveyed under any patent right of any rights of others.

General Standards Corporation assumes no responsibility resulting from omissions or errors in this manual, or from the use of information contained herein.

General Standards Corporation reserves the right to make any changes, without notice, to this product to improve reliability, performance, function, or design.

All rights reserved

No parts of this document may be copied or reproduced in any form or by any means without prior written consent of **General Standards Corporation**.

RELATED PUBLICATIONS

PLX PCI 9080 Data Book

PLX Technology Inc.
390 Potrero Avenue
Sunnyvale, CA 4085
(408) 774-3735
<http://www.plxtech.com/>

EIA-422-A – Electrical Characteristics of Balanced Voltage Digital Interface Circuits
(EIA order number EIA-RS-422A)

EIA-485 – Standard for Electrical Characteristics of Generators and Receivers for Use in Balanced Digital Multipoint Systems
(EIA order number EIA-RS-485)

EIA Standards and Publications can be purchased from:

GLOBAL ENGINEERING DOCUMENTS
15 Inverness Way East
Englewood, CO 80112
Phone: (800) 854-7179
<http://global.ihs.com/>

IEEE P1386 - Standard Mechanic for a Common Mezzanine Card Family: CMC

IEEE P1386.1 - Standard Physical and Environmental Layers for PCI Mezzanine Cards: PMC
Sponsored by the Microprocessor & Microcomputer Standards Committee (MMS) of the IEEE Computer Society

Copies of IEEE specifications available from:
Institute of Electrical and Electronics Engineers
Service Center
445 Hoes Lane
Piscataway, NJ 08855-1331 USA
<http://www.ieee.org/>

PCI Local Bus Specification Revision 2.1 June 1, 1995.

Copies of PCI specifications available from:
PCI Special Interest Group
NE 2575 Kathryn Street, #17
Hillsboro, OR 97124
<http://www.pcisig.com/>

TABLE OF CONTENTS

CHAPTER 1: INTRODUCTION	1
1.0 GENERAL DESCRIPTION.....	1
1.1 FUNCTIONAL DESCRIPTION	1
1.1.1 PMC INTERFACE	2
1.1.2 LOCAL CONTROL LOGIC.....	2
1.1.3 TRANSMIT/RECEIVE FIFOS	2
1.1.4 SERIAL/PARALLEL CONVERTERS.....	2
1.1.5 RS422/RS485 TRANSCEIVERS	2
1.1.6 CONNECTOR INTERFACE.....	2
CHAPTER 2: LOCAL SPACE REGISTERS	3
2.0 REGISTER MAP.....	3
2.1 GSC FIRMWARE REGISTERS.....	3
2.1.1 FIRMWARE REVISION: LOCAL OFFSET 0x0000.....	4
2.1.2 BOARD CONTROL: LOCAL OFFSET 0x0004	4
2.1.3 BOARD STATUS: LOCAL OFFSET 0x0008	5
2.1.4 CHANNEL TX ALMOST FLAGS: LOCAL OFFSET 0x0010 / 0x0020 / 0x0030 / 0x0040.....	5
2.1.5 CHANNEL RX ALMOST FLAGS: LOCAL OFFSET 0x0014 / 0x0024 / 0x0034 / 0x0044	5
2.1.6 CHANNEL FIFO: LOCAL OFFSET 0x0018 / 0x0028 / 0x0038 / 0x0048	6
2.1.7 CHANNEL CONTROL/STATUS: LOCAL OFFSET 0x001C / 0x002C / 0x003C / 0x004C	6
2.1.8 INTERRUPT REGISTERS	9
2.1.8.1 INTERRUPT CONTROL: LOCAL OFFSET 0x0060	10
2.1.8.2 INTERRUPT STATUS/CLEAR: LOCAL OFFSET 0x0064	10
2.1.8.3 INTERRUPT EDGE/LEVEL & INTERRUPT HI/LO: LOCAL OFFSET 0x0068 / 0x006C.....	10
2.1.9 IO CONTROL REGISTER: LOCAL OFFSET 0x0090 / 0x0094 / 0x0098 / 0x9C.....	10
2.1.10 PROGRAMMABLE CLOCK REG: LOCAL OFFSET 0x00A0 / 0x00A4 / 0x00A8 / 0x00AC	12
2.1.11 TX COUNT REGISTER: LOCAL OFFSET 0x00B0 / 0x00B4 / 0x00B8 / 0xBC.....	13
2.1.12 RX COUNT REGISTER: LOCAL OFFSET 0x00C0 / 0x00C4 / 0x00C8 / 0xCC.....	13
2.1.13 FEATURES REGISTER: LOCAL OFFSET 0x00FC.....	13
CHAPTER 3: PCI/PMC INTERFACE.....	14
3.0 PCI/PMC INTERFACE REGISTERS.....	14
3.1 PCI REGISTERS	14
3.1.1 PCI CONFIGURATION REGISTERS	14
3.1.2 LOCAL CONFIGURATION REGISTERS	15
3.1.3 RUNTIME REGISTERS.....	15
3.1.3 DMA REGISTERS	15
3.1.3.1 DMA CHANNEL MODE REGISTER: (PCI 0x80 / 0x94)	15
CHAPTER 4: PROGRAMMING.....	16
4.0 INTRODUCTION.....	16
4.1 RESETS	16
4.2 FIFO ALMOST FLAGS.....	16
4.3 DMA.....	16
4.4 INTERRUPTS	17
4.5 CLOCK SETUP.....	17
4.6 PROGRAMMABLE OSCILLATOR / PROGRAMMABLE CLOCKS	17
4.7 UPPER/LOWER CONNECTOR NAMING CONVENTION	18
CHAPTER 5: HARDWARE CONFIGURATION	19
5.1 BOARD LAYOUT	19
5.2 BOARD ID JUMPER J3.....	19

5.3	INTERFACE CONNECTORS.....	20
5.4	TERMINATION RESISTORS	21
CHAPTER 6: ORDERING OPTIONS		22
6.0	ORDERING INFORMATION.....	22
6.0.1	FIFO SIZE	22
6.0.2	INTERFACE CABLE	22
6.0.3	DEVICE DRIVERS.....	22
6.1	CUSTOM APPLICATIONS	22
APPENDIX A: COMMON PROGRAMMABLE CLOCK REGISTER VALUES.....		23
APPENDIX B: CALCULATING PROGRAMMABLE CLOCK VALUES		24

CHAPTER 1: INTRODUCTION

1.0 General Description

The PMC-SIO4AR-SYNC board is a four channel serial interface card which provides a simple synchronous serial interface capability for PCI Mezzanine Card (PMC) applications. The PMC-SIO4AR-SYNC combines a flexible parallel/serial converter and 8 external FIFOs to provide four fully independent synchronous RS422/RS485 serial channels. In addition to the standard front edge I/O connector, the PMC-SIO4AR also provides a user interface via the PMC Rear IO connector. These features, along with a high performance PCI interface engine, give the PMC-SIO4AR-SYNC unsurpassed performance in a serial interface card.

The PMC-SIO4AR-SYNC incorporates the following features:

- Four Independent Synchronous Serial Channels
- Serial Data Rates up to 10 Mbits/sec
- PMC Rear IO User Interface.
- SCSI II type 68 pin front edge I/O Connector with optional cable adapter to four DB25 connectors.
- Independent Transmit and Receive FIFO Buffers for each Serial Channel – Up to 32k Deep Each
- Fast RS485/RS422 Differential Cable Transceivers to Provide Increased Noise Immunity
- Programmable Transmit Bit Counts allow for various transmit word lengths
- Selectable Transmit Gap Bit Counts allow for a programmed number of clocks between words
- Unused Serial Channels can be programmed to provide General Purpose IO capability.
- Dual PCI DMA Engine to speed transfers and minimize host I/O overhead
- On-Board Programmable Oscillator provides increased flexibility for Baud Rate Clock generation
- A variety of device drivers are available, including VxWorks, WinNT, Win2k, Linux, and Labview

1.1 Functional Description

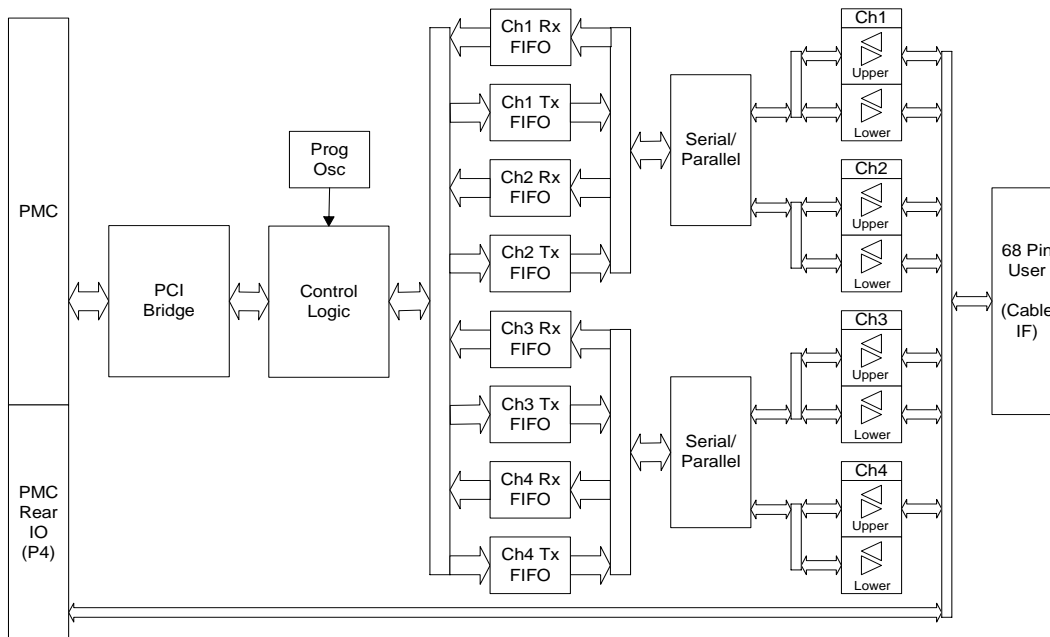

Figure 1-1 Block Diagram of PMC-SIO4AR-SYNC

1.1.1 PMC Interface

The control interface to the PMC-SIO4AR is through the PCI Mezzanine Card (PMC) interface. An industry standard PCI9080 bridge chip from PLX Technology is used to implement PCI Specification 2.1. The PCI9080 provides the 32bit, 33MHz (132MBit/sec) interface between the PMC bus and the Local 32 bit bus. In addition, the PMC P4 connector provides the Rear IO Interface for the board.

1.1.2 Local Control Logic

The control functions and glue logic for the board are implemented in an on-board FPGA. This custom logic defines local space registers to provide software control over the board functions. These functions include setup, control, and transfer of data to and from the serial controller chips.

1.1.3 Transmit/Receive FIFOs

Eight independent Transmit and Receive FIFOs provide up to 32kbytes of data buffering per channel for the serial data. Each channel has a unique transmit and receive FIFO to allow the channels to operate independently. The FIFOs allow data transfer to continue to/from the IO interface independent of PMC interface transfers and software overhead. The required FIFO size may depend on several factors including data transfer size, required throughput rate, and the software overhead (which will also vary based on OS). Deep FIFOs ensure no data is lost for critical systems.

1.1.4 Serial/Parallel Converters

The serial serial/parallel converters allow various word lengths to be transmitted or received. A Transmit Bit Count and Transmit Gap Count allow the transmit word to be customized for a variety of applications. By using the Transmit Bit Counters, the transmit serial data stream can be set to a fixed bit length and allow a fixed gap between words. The Receive Bit Counter provides the bit length of the last received serial data stream.

1.1.5 RS422/RS485 Transceivers

Data is transferred over the user interface using high-speed, differential RS485/RS422 transceivers. Industry standard differential RS485 signaling allows for longer, faster, and more reliable data connections. Socketed termination resistors allow the board to comply with both RS485 and RS422 terminations, or they may be removed for a multi-drop configuration. All transceivers are bi-directional, so that any pin may be configured to receive or transmit. This allows the user more flexibility for wiring cable connections. It also enables two SIO4 cards to be connected together via a standard, straight-thru cable.

1.1.6 Connector Interface

The PMC-SIO4AR provides two user IO interfaces – a front-side card edge connector and a rear IO PMC connection. The front-side card connector is a high-density 68 pin SCSI II type connector. All four serial channels interface via this cable connector, and are grouped to simplify separating the cable into four distinct serial connectors. The Rear IO connector provides the same RS485/RS422 differential interface to the PMC P4 connector.

CHAPTER 2: LOCAL SPACE REGISTERS

2.0 Register Map

The PMC-SIO4AR-SYNC is accessed through two sets of registers – PCI Registers (internal to PLX PCI9080) and GSC Firmware Registers. The GSC Firmware Registers are referred to as Local Space Registers and are described below. The PCI registers are discussed in Chapter 3.

2.1 GSC Firmware Registers

The GSC Firmware Registers provide the primary control/status for the PMC-SIO4AR board. These registers define general setup and control functions for the board, including interrupt handling, serial transceiver setup, and programmable clock functions. The on-board FIFOs which pass data to/from the serial channels are also mapped in this region. The following table shows the GSC Firmware Registers.

Offset Address	Size	Access*	Register Name	Default Value (Hex)
0x0000	D32	RW	Firmware Revision	010201XX
0x0004	D32	RW	Board Control	00000000
0x0008	D32	RO	Board Status	0000000X
0x000C	---	--	RESERVED	-----
0x0010	D32	RW	Ch 1 Tx Almost Full/Empty	00070007
0x0014	D32	RW	Ch 1 Rx Almost Full/Empty	00070007
0x0018	D32	RW	Ch 1 1 Data FIFO	000000XX
0x001C	D32	RW	Ch 1 Control/Status	0000CC00
0x0020	D32	RW	Ch 2 Tx Almost Full/Empty	00070007
0x0024	D32	RW	Ch 2 Rx Almost Full/Empty	00070007
0x0028	D32	RW	Ch 2 FIFO	000000XX
0x002C	D32	RW	Ch 2 Control/Status	0000CC00
0x0030	D32	RW	Ch 3 Tx Almost Full/Empty	00070007
0x0034	D32	RW	Ch 3 Rx Almost Full/Empty	00070007
0x0038	D32	RW	Ch 3 Data FIFO	000000XX
0x003C	D32	RW	Ch 3 Control/Status	0000CC00
0x0040	D32	RW	Ch 4 Tx Almost Full/Empty	00070007
0x0044	D32	RW	Ch 4 Rx Almost Full/Empty	00070007
0x0048	D32	RW	Ch 4 Data FIFO	000000XX
0x004C	D32	RW	Ch 4 Control/Status	0000CC00
0x0050-5C	---	--	RESERVED	00000000
0x0060	D32	RW	Interrupt Control	00000000
0x0064	D32	RW	Interrupt Status	00000000
0x0068	D32	RO	Interrupt Edge/Level	FFFF7777
0x006C	D32	RW	Interrupt High/Low	FFFFFFFF
0x0070-0x008C	---	--	RESERVED	-----
0x0090	D32	RW	Ch 1 IO Control	00000000
0x0094	D32	RW	Ch 2 IO Control	00000000
0x0098	D32	RW	Ch 3 IO Control	00000000
0x009C	D32	RW	Ch 4 IO Control	00000000

0x00A0	D32	RW	Ch 1 Prog Clock Divider/Osc	00129128
0x00A4	D32	RW	Ch 2 Prog Clock Divider	00000000
0x00A8	D32	RW	Ch 3 Prog Clock Divider	00000000
0x00AC	D32	RW	Ch4 Prog Clock Divider	00000000
0x00B0	D32	RW	Ch 1 Transmit Counters	00000000
0x00B4	D32	RW	Ch 2 Transmit Counters	00000000
0x00B8	D32	RW	Ch 3 Transmit Counters	00000000
0x00BC	D32	RW	Ch 4 Transmit Counters	00000000
0x00C0	D32	RW	Ch 1 Receive Counters	00000000
0x00C4	D32	RW	Ch 2 Receive Counters	00000000
0x00C8	D32	RW	Ch 3 Receive Counters	00000000
0x00CC	D32	RW	Ch 4 Receive Counters	00000000
0x00D0-0x00F8	---	--	RESERVED	-----
0x00FC	D32	RO	Features Register	000000XX

* RO = read only, RW = read/write capability

2.1.1 Firmware Revision: Local Offset 0x0000

The Firmware ID register provides version information about the firmware on the board. This is useful for technical support to identify the firmware version.

D6:0	Firmware Revision	Identifies version of specific firmware
D7	Internal/External FIFOs	0 = External FIFOs / 1 = Internal FIFOs
D15:8	Device ID	02 = SIO4A Standard
D23:16	SIO4 Board ID	02 = PMC-SIO4AR
D31:24	Misc	01 = Features Register at Local Offset 0x00FC.

2.1.2 Board Control: Local Offset 0x0004

The Board Control Register defines the general control functions for the board. The main function in this register defines the Demand mode DMA channel requests. For Demand mode DMA, there are only two physical DMA channels which must be shared between the eight serial channels (Rx and TX for each of four channels). The Demand Mode DMA Channel Request allows the software to multiplex the DMA channels. This is typically handled by the driver – the end user should have no need to change this register.

D2: 0 Demand Mode DMA Channel 0 Request

D 2	D 1	D 0	Demand Mode DMA 0 Channel
0	0	0	Channel 1 Rx
1	0	0	Channel 1 Tx
0	1	0	Channel 2 Rx
1	1	0	Channel 2 Tx
0	0	1	Channel 3 Rx
1	0	1	Channel 3 Tx
0	1	1	Channel 4 Rx
1	1	1	Channel 4 Tx

D3 Reserved

D4:6 Demand Mode DMA Channel 1 Request

D 6	D 5	D 4	Demand Mode DMA 1 Channel
0	0	0	Channel 1 Rx
1	0	0	Channel 1 Tx
0	1	0	Channel 2 Rx
1	1	0	Channel 2 Tx
0	0	1	Channel 3 Rx
1	0	1	Channel 3 Tx
0	1	1	Channel 4 Rx
1	1	1	Channel 4 Tx

D31:7 Reserved

2.1.3 Board Status: Local Offset 0x0008

The Board Status Register gives general overall status for a board. The Board Jumpers are physical jumpers which can be used to distinguish between boards if multiple SIO4 boards are present in a system.

- D0** Board Jumper 0 (0=jumper J3:1-2 installed)
- D1** Board Jumper 1 (0=jumper J3:3-4 installed)
- D31:D2** Reserved

2.1.4 Channel TX Almost Flags: Local Offset 0x0010 / 0x0020 / 0x0030 / 0x0040

The Tx Almost Flag Registers are used to program the Almost Full and Almost Empty Flags in the transmit FIFOs. The FIFO almost flags may be used to determine a fill level for a specific transfer size, or used for demand mode DMA. Setting this register does not automatically program the almost flags – the registers will be programmed during a FIFO Reset command. See 4.2 **FIFO Almost Flags** for further information concerning Tx FIFO Almost Flag programming.

- D15:0** TX Almost Empty Flag Value
Almost Empty Flag will be asserted when the FIFO contains “Almost Empty Value” words or fewer.
- D31:16** TX Almost Full Flag Value
Almost Full Flag will be asserted when the FIFO has space for “Almost Full Value” words or fewer (i.e. FIFO contains (FIFO Size – Almost Full Value) words or more.)

2.1.5 Channel Rx Almost Flags: Local Offset 0x0014 / 0x0024 / 0x0034 / 0x0044

The Rx Almost Flag Registers are used to program the Almost Full and Almost Empty Flags in the receive FIFOs. The FIFO almost flags may be used to determine a fill level for a specific transfer size, or used for demand mode DMA. Setting this register does not automatically program the almost flags – the registers will be programmed during a FIFO Reset command. See 4.2 **FIFO Almost Flags** for further information concerning Rx FIFO Almost Flag programming.

- D15:0** Rx Almost Empty Flag Value
Almost Empty Flag will be asserted when the FIFO contains “Almost Empty Value” words or fewer.
- D31:16** Rx Almost Full Flag Value
Almost Full Flag will be asserted when the FIFO has space for “Almost Full Value” words or fewer (i.e. FIFO contains (FIFO Size – Almost Full Value) words or more.)

2.1.6 Channel FIFO: Local Offset 0x0018 / 0x0028 / 0x0038 / 0x0048

The Channel FIFO Register passes serial data to/from the serial controller chips. The same register is used to access both the Transmit FIFO (writes) and Receive FIFO (reads).

D7:0 Channel FIFO Data
D31:8 Reserved

2.1.7 Channel Control/Status: Local Offset 0x001C / 0x002C / 0x003C / 0x004C

The Channel Control/Status Register provides the reset functions and data transceiver enable controls, and the FIFO Flag status for each channel.

D31:15 / D7:0 Channel Control Bits

D0 Reset Channel TX FIFO (Pulsed)

1 = Reset Channel TX FIFOs.

Notes:

- This value will automatically clear to '0'.
- If the Channel TX Almost Flag register is not zero, the Tx Almost Flag Values will automatically be programmed following the FIFO Reset.
- Software must wait approximately 1ms following a FIFO Reset before accessing the Local Board Registers again.

D1 Reset Channel Rx FIFO (Pulsed)

1 = Reset Channel Rx FIFOs.

Notes:

- This value will automatically clear to '0'.
- If the Channel Rx Almost Flag register is not zero, the Rx Almost Flag Values will automatically be programmed following the FIFO Reset.

D5:2 Enables for data signals through the transmit and receive buffers to and from the user IO connector. See 4.8 Upper/Lower Cable Naming Convention for an explanation of "Upper/Lower".

Note: If D5:D2 = "0000", the channel is set to General Purpose IO. This means External Sync Logic is disabled and the IO signals are controlled from the Channel IO Control Register.

D2 Channel Lower Transmit Data Enable

1 = Channel Lower TxD driven to IO connector.

0 = Channel Lower TxD disabled (tristate).

D3 Channel Upper Transmit Data Enable

1 = Channel Upper TxD driven to IO connector.

0 = Channel Upper TxD disabled (tristate).

D4 Channel Lower Receive Data Enable

1 = Channel Lower RxD received in from IO connector.

0 = Channel Lower RxD disabled (tristate).

D5 Channel Upper Rx Data Enable

1 = Channel Upper RxD received in from IO connector.

Note: Upper RxD will NOT be enabled if D4 (Lower RxD) also enabled.

0 = Channel Upper RxD disabled (tristate).

D7:6 Reserved

- D16** Receive Enable
0 = Receiver Disabled
1 = Receiver Enabled
- D17** Transmit Enable
0 = Transmitter Disabled
1 = Transmitter Enabled
- D18** Stop Transmit On FIFO Empty
0 = Transmitter remains enabled under software control (D17)
1 = Transmitter will be disabled (D17=0) when transmitter becomes empty
- D19** RxClk Polarity
1 = Clock on Rising Edge (default)
0 = Clock on Falling Edge
- D20** TxClk Polarity
1 = TxClk on Rising Edge (default)
0 = TxClk on Falling Edge
- D21** Idle TxClk
1 = TxClk present while Idle (not Transmitting)
0 = No TxClk while Idle (TxClk present only when Envelope present)
- D22** TxClk Source
0 = TxClk Source Internal
1 = TxClk Source External
- D23** Receive Bit Count Reset
1 = Reset Rx Bit Count
- D24** Receive MSB/LSB
0 = Receive MSB first
1 = Receive LSB first
- D25** Transmit MSB/LSB
0 = Transmit MSB first
1 = Transmit LSB first
- D26** Receive Envelope Polarity
1 = Rx Envelope Active Lo
0 = Rx Envelope Active Hi
- D27** Transmit Envelope Polarity
1 = Tx Envelope Active Lo
0 = Tx Envelope Active Hi
- D28** Internal Loopback
0 = Normal Mode
1 = Internal Loopback (for High speed test)
- D29** Dual Sync
0 = Normal Mode
1 = Dual Sync Mode
- D30** Reserved

D31 / D15:8 Channel Status Bits

- D8** Channel Tx FIFO Empty Flag Lo (Active Low -- 0=Tx Empty)
- D9** Channel Tx FIFO Almost Empty Flag Lo (Active Low -- 0=Tx Almost Empty)
- D10** Channel Tx FIFO Almost Full Flag Lo (Active Low -- 0=Tx Almost Full)
- D11** Channel Tx FIFO Full Flag Lo (Active Low -- 0=Tx Full)
- D12** Channel Rx FIFO Empty Flag Lo (Active Low -- 0=Rx Empty)
- D13** Channel Rx FIFO Almost Empty Flag Lo (Active Low -- 0=Rx Almost Empty)
- D14** Channel Rx FIFO Almost Full Flag Lo (Active Low -- 0=Rx Almost Full)
- D15** Channel Rx FIFO Full Flag Lo (Active Low -- 0=Rx Full)
- D31** Receive Count Error

2.1.8 Interrupt Registers

There are 32 on-board interrupt sources (in addition to USC interrupts and PLX interrupts), each of which may be individually enabled. Four interrupt registers control the on-board interrupts – Interrupt Control, Interrupt Status, Interrupt Edge/Level, and Interrupt Hi/Lo. The 32 Interrupt sources are:

IRQ #	Source	Default Level	Alternate Level
IRQ0	Unused	--	--
IRQ1	Channel 1 Tx FIFO Almost Empty	Rising Edge	Falling Edge
IRQ2	Channel 1 Rx FIFO Almost Full	Rising Edge	Falling Edge
IRQ4:3	Unused	--	--
IRQ5	Channel 2 Tx FIFO Almost Empty	Rising Edge	Falling Edge
IRQ6	Channel 2 Rx FIFO Almost Full	Rising Edge	Falling Edge
IRQ8:7	Unused	--	--
IRQ9	Channel 3 Tx FIFO Almost Empty	Rising Edge	Falling Edge
IRQ10	Channel 3 Rx FIFO Almost Full	Rising Edge	Falling Edge
IRQ12:11	Unused	--	--
IRQ13	Channel 4 Tx FIFO Almost Empty	Rising Edge	Falling Edge
IRQ14	Channel 4 Rx FIFO Almost Full	Rising Edge	Falling Edge
IRQ15	Unused	--	--
IRQ16	Channel 1 Tx FIFO Empty	Rising Edge	Falling Edge
IRQ17	Channel 1 Tx FIFO Full	Rising Edge	Falling Edge
IRQ18	Channel 1 Rx FIFO Empty	Rising Edge	Falling Edge
IRQ19	Channel 1 Rx FIFO Full	Rising Edge	Falling Edge
IRQ20	Channel 2 Tx FIFO Empty	Rising Edge	Falling Edge
IRQ21	Channel 2 Tx FIFO Full	Rising Edge	Falling Edge
IRQ22	Channel 2 Rx FIFO Empty	Rising Edge	Falling Edge
IRQ23	Channel 2 Rx FIFO Full	Rising Edge	Falling Edge
IRQ24	Channel 3 Tx FIFO Empty	Rising Edge	Falling Edge
IRQ25	Channel 3 Tx FIFO Full	Rising Edge	Falling Edge
IRQ26	Channel 3 Rx FIFO Empty	Rising Edge	Falling Edge
IRQ27	Channel 3 Rx FIFO Full	Rising Edge	Falling Edge
IRQ28	Channel 4 Tx FIFO Empty	Rising Edge	Falling Edge
IRQ29	Channel 4 Tx FIFO Full	Rising Edge	Falling Edge
IRQ30	Channel 4 Rx FIFO Empty	Rising Edge	Falling Edge
IRQ31	Channel 4 Rx FIFO Full	Rising Edge	Falling Edge

For all interrupt registers, the IRQ source (IRQ31:IRQ0) will correspond to the respective data bit (D31:D0) of each register. (D0 = IRQ0, D1 = IRQ1, etc.)

All FIFO interrupts are edge triggered active high. This means that an interrupt will be asserted (assuming it is enabled) when a FIFO Flag transitions from FALSE to TRUE (rising edge triggered) or TRUE to FALSE (falling edge). For example: If Tx FIFO Empty Interrupt is set for Rising Edge Triggered, the interrupt will occur when the FIFO transitions from NOT EMPTY to EMPTY. Likewise, if Tx FIFO Empty Interrupt is set as Falling Edge Triggered, the interrupt will occur when the FIFO transitions from EMPTY to NOT EMPTY.

All Interrupt Sources share a single interrupt request back to the PCI9080 PLX chip. Likewise, all USC interrupt sources share a single interrupt request back to the interrupt controller and must be further qualified in the USC chip. See Section **4.4 Interrupts** for further interrupt programming information.

2.1.8.1 Interrupt Control: Local Offset 0x0060

The Interrupt Control register individually enables each interrupt source. A ‘1’ enables each interrupt source; a ‘0’ disables. An interrupt source must be enabled for an interrupt to be generated.

2.1.8.2 Interrupt Status/Clear: Local Offset 0x0064

The Interrupt Status Register shows the status of each respective interrupt source. If an interrupt source is enabled in the Interrupt Control Register, a ‘1’ in the Interrupt Status Register indicates the respective interrupt has occurred. The interrupt source will remain latched until the interrupt is cleared, either by writing to the Interrupt Status/Clear Register with a ‘1’ in the respective interrupt bit position, or the interrupt is disabled in the Interrupt Control register. If an interrupt source is not asserted or the interrupt is not enabled, writing a ‘1’ to that bit in the Interrupt Status/Clear Register will have no effect on the interrupt.

If the interrupt source is a level triggered interrupt (USC interrupt), the interrupt status may still be ‘1’ even if the interrupt is disabled. This indicates the interrupt condition is true, regardless of whether the interrupt is enabled. Likewise, if a level interrupt is enabled and the interrupt source is true, the interrupt status will be reasserted immediately after clearing the interrupt, and an additional interrupt will be requested.

2.1.8.3 Interrupt Edge/Level & Interrupt Hi/Lo: Local Offset 0x0068 / 0x006C

The Interrupt Edge/Level and Interrupt Hi/Lo Registers define each interrupt source as level hi, level lo, rising edge, or falling edge. All PMC-SIO4AR interrupts are edge triggered except the USC interrupts which are level triggered. Since the interrupt behavior is fixed, the Interrupt Edge/Level register cannot be changed by the user. (Read Only)

The FIFO Flags may be defined as rising edge or falling edge via the Interrupt Hi/Lo Register. For example, a rising edge of the TX Empty source will generate an interrupt when the TX FIFO becomes empty. Defining the source as falling edge will trigger an interrupt when the TX FIFO becomes “NOT Empty”.

2.1.9 IO Control Register: Local Offset 0x0090 / 0x0094 / 0x0098 / 0x9C

When a channel is setup for General Purpose IO in the Channel Control Register, the IO Control Register controls the function of the General Purpose IO pins.

D7:0	IO Setup
D0	0 => CTS/GPIO0 = Input 1 => CTS/GPIO0 = Output
D1	0 => Lower RxD/GPIO1 = Input DCD/GPIO3 = Input 1 => Lower RxD/GPIO1 = Output DCD/GPIO3 = Output
D2	0 => Lower RxCk/GPIO2 = Input 1 => Lower RxCk/GPIO2 = Output
D3	0 => DCD/GPIO3 = Input (D1 must be set to 0 - Input) 1 => DCD/GPIO3 = Output (D1 must be set to 1 - Output)
D4	0 => Upper RxD /GPIO4 = Input (D1 must be set to 1 - Output) 1 => Upper RxD /GPIO4 = Output (D1 must be set to 0 - Input)
D5	0 => Upper RxCk /GPIO5 = Input (D2 must be set to 1 - Output) 1 => Upper RxCk /GPIO5 = Output (D2 must be set to 0 - Input)
D7:D6	Reserved

D15:8 Output Value / Input Latch

If a pin is setup as an Output (via IO Setup D7-D0), D15-D8 define the output value.

D8	CTS/GPIO0 Output Value
D9	Lower RxD/GPIO1 Output Value
D10	Lower RxCk/GPIO2 Output Value
D11	DCD/GPIO3 Output Value
D12	Upper RxD /GPIO4 Output Value
D13	Upper RxCk /GPIO5 Output Value
D15:D14	Reserved

If a pin is setup as an Input (via IO Setup D7-D0), D15-D8 define whether the Input Value is latched (1). If the input is latched, the input latch behavior is defined by bits D31-D24. Once an input is latched, resetting the corresponding bit below will clear the latched input.

D8	CTS/GPIO0 Input latched
D9	Lower RxD/GPIO1 Input latched
D10	Lower RxCk/GPIO2 Input latched
D11	DCD/GPIO3 Input latched
D12	Upper RxD /GPIO4 Input latched
D13	Upper RxCk /GPIO5 Input latched
D15:D14	Reserved

D23:16 Input Value

If a pin is setup as an Input (via IO Setup D7-D0), D23-D16 reflect the input value. If an input is defined as latched, a '1' will indicate the latched condition occurred.

D16	CTS/GPIO0 Input Value
D17	Lower RxD/GPIO1 Input Value
D18	Lower RxCk/GPIO2 Input Value
D19	DCD/GPIO3 Input Value
D20	Upper RxD /GPIO4 Input Value
D21	Upper RxCk /GPIO5 Input Value
D23:D22	Reserved

D31:24 Input Latch

If a pin is setup as an Input (via IO Setup D7-D0), and D15-D8 define an input as latched, then D31-D24 define the latching condition – lo level, hi level, falling edge, or rising edge.

D30	Level (0) / Edge (1) latched inputs
D24	CTS/GPIO0 Polarity 0 => If D30=0, level lo If D30=1, level hi 1 => If D30=0, falling edge If D30=1, rising edge
D25	Lower RxD/GPIO1 Polarity 0 => If D30=0, level lo If D30=1, level hi 1 => If D30=0, falling edge If D30=1, rising edge

D26	Lower RxClk/GPIO2 Polarity 0 => If D30=0, level lo If D30=1, level hi 1 => If D30=0, falling edge If D30=1, rising edge
D27	DCD/GPIO3 Polarity 0 => If D30=0, level lo If D30=1, level hi 1 => If D30=0, falling edge If D30=1, rising edge
D28	Upper RxClk /GPIO4 Polarity 0 => If D30=0, level lo If D30=1, level hi 1 => If D30=0, falling edge If D30=1, rising edge
D29	Upper RxClk /GPIO5 Polarity 0 => If D30=0, level lo If D30=1, level hi 1 => If D30=0, falling edge If D30=1, rising edge
D31	Reserved

2.1.10 Programmable Clock Reg: Local Offset 0x00A0 / 0x00A4 / 0x00A8 / 0x00AC

The Programmable Clock Registers allow the user to program the on-board programmable oscillator and configure the channel clock post-dividers. Since there is only a single programmable oscillator, the output of this oscillator will be used as the input to all four channel clock post-dividers. Figure 2-1 shows the Programmable clock registers.

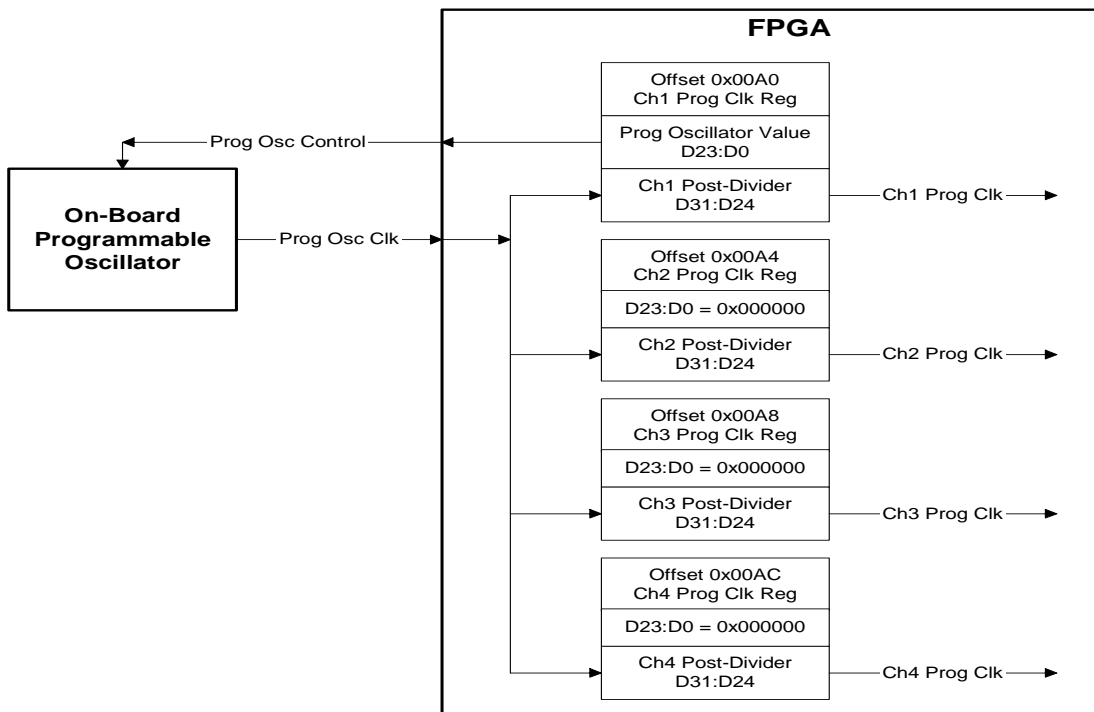

Figure 2-1: Channel Programmable Clock Registers

Loading the Programmable Clock Register for Channel 1 (Offset 0x00A0) will automatically program the on-board oscillator. See Section **4.6 Programmable Oscillator** for more information of programming the on-board oscillator.

Since the On-Board Programmable Oscillator has a minimum clock frequency of 400 kHz, bits D31:D24 of the Programmable Clock Register may be used to further “Post Divide” the Programmable Oscillator input. This allows for programmable clock frequencies below 2 kHz to be obtained.

For Channel 1 (Offset 0x00A0):

- D22:0** Programmable Oscillator Program Value
- D23** Programming In Progress Status
After writing the Ch1 Programmable Clock Register, this bit will remain ‘1’ while the on-board oscillator is being programmed.
- D31:24** Ch1 Programmable Clock Post-Divide Value (0-255)
NOTE: If the post divide value is set to 0x00 or 0x01, no post divide will be performed.
(Programmable Clock Frequency = Programmable Oscillator Frequency)

For Channels 2-4 (Offsets 0x00A4 / 0x00A8 / 0x00AC):

- D23:0** 0x000000
- D31:24** Programmable Clock Post-Divide Value (0-255)
NOTE: If the post divide value is set to 0x00 or 0x01, no post divide will be performed.
(Programmable Clock Frequency = Programmable Oscillator Frequency)

2.1.11 Tx Count Register: Local Offset 0x00B0 / 0x00B4 / 0x00B8 / 0xBC

- D15..0** Transmit Bit Count
These bits indicate the number of consecutive bits the SIO4 should send in each transmit word. This value is also used to flag an error if the specified count is not received during a receive cycle.
- D31..16** Gap Bit Count
If transmit enable is set, these bits indicate the delay, in transmit clock cycles, between transmitted words. To output a continuous stream of bits, this value may be set to zero. These bits have no affect if the SIO4 is in receive mode.

2.1.12 Rx Count Register: Local Offset 0x00C0 / 0x00C4 / 0x00C8 / 0xCC

- D15..0** Receive Bit Count
If receive enable is set, these bits indicate the size, in bits, of the last received word. These bits have no affect if the SIO4 is in transmit mode.

2.1.13 Features Register: Local Offset 0x00FC

The Features Register allows software to account for added features in the firmware versions. Bits will be assigned as new features are added.

- D3:0** Programmable Clock Configuration – 01 = ICD2053B
- D4** FIFO Counters/Size Present
- D31:5** RESERVED

CHAPTER 3: PCI/PMC INTERFACE

3.0 PCI/PMC Interface Registers

A PCI9080 I/O Accelerator from PLX Technology handles the PCI/PMC Interface. The PCI/PMC interface is compliant with the 5V, 33MHz 32-bit PCI Specification 2.1. The PCI9080 provides dual DMA controllers for fast data transfers to and from the on-board FIFOs. Fast DMA burst accesses provide for a maximum burst throughput of 132MB/s to the PCI interface. To reduce CPU overhead during DMA transfers, the controller also implements Chained (Scatter/Gather) DMA, as well as Demand Mode DMA.

Since many features of the PCI9080 are not utilized in this design, it is beyond the scope of this document to duplicate the [PCI9080 User's Manual](#). Only those features, which will clarify areas specific to the PMC-SIO4AR are detailed here. Please refer to the [PCI9080 User's Manual](#) (See Related Publications) for more detailed information. Note that the BIOS configuration and software driver will handle most of the PCI9080 interface. Unless the user is writing a device driver, the details of this PCI/PMC Interface Chapter may be skipped.

3.1 PCI Registers

The PLX 9080 contains many registers, many of which have no effect on the PMC-SIO4AR performance. The following section attempts to filter the information from the PCI9080 manual to provide the necessary information for a PMC-SIO4AR specific driver.

The PMC-SIO4AR uses an on-board serial EEPROM to initialize many of the PCI9080 registers after a PCI Reset. This allows board specific information to be preconfigured.

3.1.1 PCI Configuration Registers

The PCI Configuration Registers allow the PCI controller to identify and control the cards in a system.

PCI device identification is provided by the Vendor ID/Device ID (Addr 0x0000) and Sub-Vendor ID/Sub-Device ID Registers (0x002C). The following definitions are unique to the General Standards SIO4A boards. All drivers should verify the ID/Sub-ID information before attaching to this card. These values are fixed via the Serial EEPROM load following a PCI Reset, and cannot be changed by software.

Vendor ID	0x10B5	PLX Technology
Device ID	0x9080	PCI9080
Sub-Vendor ID	0x10B5	PLX Technology
Sub-Device ID	0x2401	GSC SIO4

The configuration registers also setup the PCI IO and Memory mapping for the PMC-SIO4AR. The PCI9080 is setup to use PCIBAR0 and PCIBAR1 to map the internal PLX registers into PCI Memory and IO space respectively. PCIBAR2 will map the Local Space Registers into PCI memory space, and PCIBAR3 is unused. Typically, the OS will configure the PCI configuration space.

For further information of the PCI configuration registers, please consult the [PLX Technology PCI9080 Manual](#).

3.1.2 Local Configuration Registers

The Local Configuration registers give information on the Local side implementation. These include the required memory size. The SIO4 memory size is initialized to 4k Bytes. All other Local Registers initialize to the default values described in the PCI9080 Manual.

3.1.3 Runtime Registers

The Runtime registers consist of mailbox registers, doorbell registers, and a general-purpose control register. The mailbox and doorbell registers are not used and serve no purpose on the PMC-SIO4AR. All other Runtime Registers initialize to the default values described in the PCI9080 Manual.

3.1.3 DMA Registers

The Local DMA registers are used to setup the DMA transfers to and from the on-board FIFOs. DMA is supported only to the four FIFO locations. The PMC-SIO4AR supports both Demand (DREQ# controlled) and Non-Demand mode DMA. Both Channel 0 and Channel 1 DMA are supported.

3.1.3.1 DMA Channel Mode Register: (PCI 0x80 / 0x94)

The DMA Channel Mode register must be setup to match the hardware implementation

Bit	Description	Value	Notes
D1:0	Local Bus Width	11 = 32 bit	Although the serial FIFOs only contain 8 bits of data, the register access is still a 32bit access. While it may be possible to “pack” the data by setting the Local Bus Width to 8, it is beyond the scope of this manual to determine if/how this could work.
D5:2	Internal Wait States	0000 = Unused	
D6	Ready Input Enable	1 = Enabled	
D7	Bterm# Input Enabled	0 = Unused	
D8	Local Burst Enable	1 = Supported	Bursting allows fast back-to-back accesses to the FIFOs to speed throughput
D9	Chaining Enable (Scatter Gather DMA)	X	DMA source addr, destination addr, and byte count are loaded from memory in PCI Space.
D10	Done Interrupt Enable	X	DMA Done Interrupt
D11	Local Addressing Mode	1 = No Increment	DMA to/from FIFOs only
D12	Demand Mode Enable	X	Demand Mode DMA is supported for FIFO accesses on the PMC-SIO4AR. (See Section 4.3)
D13	Write & Invalidate Mode	X	
D14	DMA EOT Enable	0 = Unused	
D15	DMA Stop Data Transfer Enable	0 = BLAST terminates DMA	
D16	DMA Clear Count Mode	0 = Unused	
D17	DMA Channel Interrupt Select	X	
D31:18	Reserved	0	

CHAPTER 4: PROGRAMMING

4.0 Introduction

This section addresses common programming questions when developing an application for the SIO4.

4.1 Resets

Each serial channel provides control for two unique reset sources: a Transmit FIFO Reset, and a Receive FIFO Reset. All resets are controlled from the GSC Channel Control/Status Registers.

The FIFO resets allow each individual FIFO (Tx and Rx) to be reset independently. In addition to clearing the FIFO, the Almost Empty and Almost Full flags are programmed following a FIFO reset. If the FIFO Almost Values are set to zero prior to a FIFO reset, the Almost Empty/Full flags are NOT programmed (the FIFO Flags will be set at their default value of 7). Section 4.2 provides further information about the FIFO Almost Flags.

4.2 FIFO Almost Flags

The FIFO Almost Empty and Almost Full flags on the PMC-SIO4AR provide a way for the user to approximate the amount of data in the FIFO. This is useful in determining when a data transfer is complete or determining the amount of data which can be safely read from/written to the FIFO. The flags are also used during Demand Mode DMA to set the request levels. The Almost Flags are fully programmable by the user.

Each channel provides two 32 bit registers for setting the Almost Full/Empty values: the TX FIFO Almost Register (See Section 2.1.5) and the RX FIFO Almost Register (See Section 2.1.6). Each of these registers is further divided into two 16 bit words: D31-D16 = Almost Full Value; D15-D0 = Almost Empty Value.

The Almost Flag value represents the number of bytes from each respective “end” of the FIFO. The Almost Empty value represents the number of bytes from empty, and the Almost Full value represents the number of bytes from full (NOT the number of bytes from empty). For example, the default value of “0x0007 0007” in the FIFO Almost Register means that the Almost Empty Flag will indicate when the FIFO holds 0x0007 bytes or fewer, and will transition as the 8th byte is read or written. The Almost Full Flag indicates the FIFO contains (FIFO Size – 0x7) bytes or more. For the standard 32Kbyte FIFO, an Almost Full value of 0x7 will cause the Almost Full flag to be asserted when the FIFO contains 32761 (32k – 7) or more bytes of data .

The values placed in the FIFO Almost Registers are programmed to the FIFO chips whenever a FIFO reset is performed. The proper steps to program these values are:

- Set the respective FIFO Almost Register(s)
- Perform a FIFO reset of the respective FIFO
- The value in the almost register is now programmed into the FIFO chips

If either (or both) FIFO Almost Empty Register or FIFO Almost Full Register is set to a value of 0x0000 during a FIFO reset, the Almost Flags will not be programmed and the flags will be set to the FIFO chip default of 7 bytes from empty and 7 bytes from full.

4.3 DMA

The PCI DMA functionality allows data to be transferred between host memory and the PMC-SIO4AR onboard FIFOs with the least amount of CPU overhead. The PCI9080 bridge chip handles all PCI DMA functions, and the device driver should handle the details of the DMA transfer.

There are two DMA modes – Demand Mode DMA and Non-Demand Mode DMA. Demand Mode DMA refers to data being transferred on demand. For receive, this means data will be transferred as soon as it is received into the FIFO. Likewise, for transmit, data will be transferred to the FIFOs as long as the FIFO is not Almost Full. The disadvantage to Demand Mode DMA is that the DMA transfers are dependent on the user data interface. If the user data interface hangs, the Demand mode DMA transfer will also stop. If a timeout occurs, there is no way to determine the exact amount of data transferred before it was aborted.

On the other hand, Non-Demand Mode DMA does not check the FIFO empty/full flags before or during the data transfer – it simply assumes there is enough available FIFO space to complete the transfer. If the transfer size is larger than the available data, the transfer will complete with invalid results.

Non-Demand Mode DMA is the safer mode, but it may require more user intervention to ensure the requested data size is available. Demand Mode DMA requires less software control, but runs the risk of losing data due to an incomplete transfer. The user will need to evaluate each situation separately to decide whether DMA is necessary, and if so, which mode.

4.4 Interrupts

The PMC-SIO4AR has a number of interrupt sources which are passed to the host CPU via the PCI Interrupt A. Since there is only one physical interrupt source, the interrupts pass through a number of “levels” to get multiplexed onto this single interrupt. The interrupt originates in the PCI9080 PCI Bridge, which combines the internal PLX interrupt sources (DMA) with the local space interrupt. The driver will typically take care of setting up and handling the PCI9080 interrupts. The single Local Interrupt is made up of the interrupt sources described in Section 2.1.10. . The user should be aware that interrupts must be enabled at each level for an interrupt to occur. For example, if a FIFO interrupt is used, it must be setup and enabled in the GSC Firmware Interrupt Control Register, as well as enabled in the PCI9080. In addition, the interrupt must be acknowledged and/or cleared at each level following the interrupt.

4.5 Clock Setup

Figure 4-1 shows the relationship of the various clock sources on the PMC-SIO4AR board. These clock sources can be most simply viewed in three sections: On-Board Programmable Clocks, IO connector Clocks, and USC Clocks.

The Programmable Clocks consist of a single on-board programmable oscillator and four post-divide clocks (one for each channel). The single programmable oscillator clock is used as the input for each of the programmable clock post dividers, which will allow each channel to have a unique programmable clock input. These programmable clocks are further described in sections 2.1.12 and 4.6.

The IO Connector Clocks consist of the cable RxClk and cable TxClk for each channel. The RxClk is always an input and the cable TxClk is always an output.

4.6 Programmable Oscillator / Programmable Clocks

The On-Board Programmable Oscillator is programmed by writing to the Channel 1 Programmable Clock Register at Local Address offset 0x00A0 (See Section 2.1.12). In order to program the oscillator, it is necessary to calculate a “control word” to program the correct oscillator frequency. Cypress Semiconductor provides a Windows program called BitCalc to assist in calculating this value. This program should be included with the documentation package. If not, it is available from General Standards (contact tech support). The clock generator device is an ICD2053B with an input frequency of 20MHz. The default oscillator value at power up or following a board reset is 20MHz. The actual transmit clock/data speed will be one half the frequency of the programmable oscillator, or 10 MHz after power up.

The output frequency of the programmable oscillator may be programmed from 20MHz to a minimum of about 400 kHz. Since a slower oscillator than 400 KHz may be required, bits D31:D24 of the Programmable Clock Registers allow the user to further divide the input clock. There is a separate post-divider for each serial channel, so each channel can have a unique clock frequency.

For further information, Section **2.1.12** details the Programmable Clock registers. Section **4.5 Clock Setup** provides information on how the programmable clocks can be best utilized. **Appendix A** provides common frequencies and their associated programmable oscillator values. **Appendix B** describes how to calculate programmable clock register values for frequencies other than those listed in **Appendix A**.

NOTE: Bit D23 of the Ch 1 Prog Clock Divider is used to indicate when the clock chip is in the process of programming. After setting a value in this register, software should wait until bit D23 clears before proceeding on with program. Otherwise indeterminate operation of the clock may occur.

4.7 Upper/Lower Connector Naming Convention

Since all the cable transceivers are bidirectional, the serial Data and Clock signals can be transmitted or received on two separate IO connector pins. The naming convention “Upper” and “Lower” is used in order to differentiate between these two pins with identical function. Typically, one pin is used for receive data, and the other pin is used for transmit. Separate controls for the transmit / receive enables allow the user flexibility to monitor the transmit line or perform a standalone loop back test. This also allows two SIO4 boards to be connected directly or two channels to be connected directly using standard cabling options by simply configuring the transmit and receive pins correctly.

CHAPTER 5: HARDWARE CONFIGURATION

5.1 Board Layout

The following figure is a drawing of the physical components of the PMC-SIO4AR:

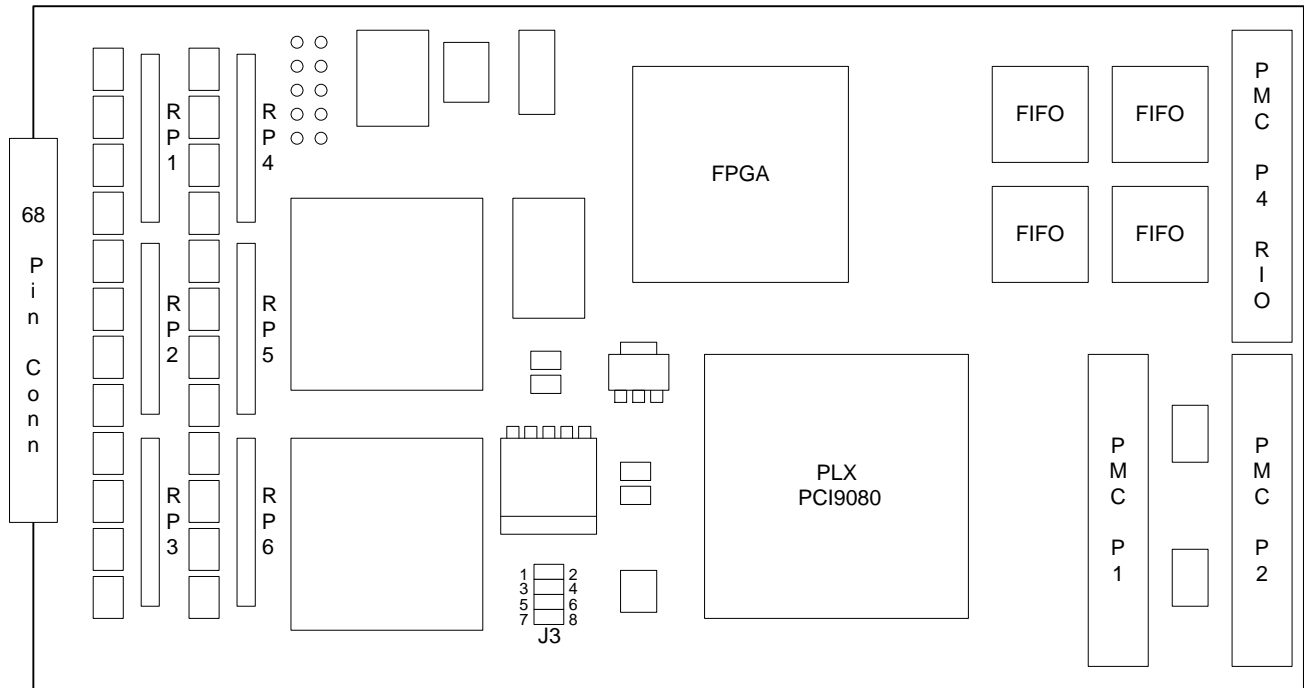

Figure 5-1: Board Layout

5.2 Board ID Jumper J3

Jumper J3 allows the user to set the Board ID in the GSC Board Status Register (See Section 2.1.3). This is useful to uniquely identify a board if more than one PMC-SIO4AR card is in a system. When the Board ID jumper is installed, it will read '0' in the Board Status Register. The Board Status Register bit will report '1' when the jumper is removed. Refer to Figure 5.1-1 for Jumper J3 location.

J3 Jumper	Description	Notes
1 - 2	Board ID 0	Defines Board ID 0 In Board Status Register
3 - 4	Board ID 1	Defines Board ID 1 In Board Status Register
5 - 6	Reload FPGA on PCI Reset	Should be installed for normal operation
7 - 8	PLX EEPROM Config	Must be installed for normal operation

Jumpers 5/6 and 7/8 are installed at the factory and should not be removed for normal operation.

5.3 Interface Connectors

There are two user interface connections on the PMC-SIO4AR - A SCSI II type 68-pin connector (female) mounted to the front edge of the board (P2), and the PMC P4 Rear IO Connector. The part number for the 68 pin front edge connector is AMP 787170-7. The mating connector is AMP 749111-6 or equivalent.

The pin out for both connectors is shown below.

P2, Row A	Pin #	P2, Row B	Pin #
No Connect	1	No Connect	35
No Connect	2	No Connect	36
No Connect	3	No Connect	37
No Connect	4	No Connect	38
Ch1 Upper Envelope / IO 0 +	5	Ch3 Upper Envelope / IO 0 +	39
Ch1 Upper Envelope / IO 0 -	6	Ch3 Upper Envelope / IO 0 -	40
Ch1 Lower RxD/TxD / IO 1+	7	Ch3 Lower RxD/TxD / IO 1+	41
Ch1 Lower RxD/TxD / IO 1 -	8	Ch3 Lower RxD/TxD / IO 1 -	42
Ch1 Lower RxClk/TxClk / IO 2 +	9	Ch3 Lower RxClk/TxClk / IO 2 +	43
Ch1 Lower RxClk/TxClk / IO 2 -	10	Ch3 Lower RxClk/TxClk / IO 2 -	44
Ch1 Lower Envelope / IO 3 +	11	Ch3 Lower Envelope / IO 3 +	45
Ch1 Lower Envelope / IO 3 -	12	Ch3 Lower Envelope / IO 3 -	46
Ch1 Upper RxD/TxD / IO 4 +	13	Ch3 Upper RxD/TxD / IO 4 +	47
Ch1 Upper RxD/TxD / IO 4 -	14	Ch3 Upper RxD/TxD / IO 4 -	48
Ch1 Upper RxClk/TxClk / IO 5+	15	Ch3 Upper RxClk/TxClk / IO 5+	49
Ch1 Upper RxClk/TxClk / IO 5 -	16	Ch3 Upper RxClk/TxClk / IO 5 -	50
Ground	17	Ground	51
Ground	18	Ground	52
Ch2 Upper Envelope / IO 0 +	19	Ch4 Upper Envelope / IO 0 +	53
Ch2 Upper Envelope / IO 0 -	20	Ch4 Upper Envelope / IO 0 -	54
Ch2 Lower RxD/TxD / IO 1+	21	Ch4 Lower RxD/TxD / IO 1+	55
Ch2 Lower RxD/TxD / IO 1 -	22	Ch4 Lower RxD/TxD / IO 1 -	56
Ch2 Lower RxClk/TxClk / IO 2 +	23	Ch4 Lower RxClk/TxClk / IO 2 +	57
Ch2 Lower RxClk/TxClk / IO 2 -	24	Ch4 Lower RxClk/TxClk / IO 2 -	58
Ch2 Lower Envelope / IO 3 +	25	Ch4 Lower Envelope / IO 3 +	59
Ch2 Lower Envelope / IO 3 -	26	Ch4 Lower Envelope / IO 3 -	60
Ch2 Upper RxD/TxD / IO 4 +	27	Ch4 Upper RxD/TxD / IO 4 +	61
Ch2 Upper RxD/TxD / IO 4 -	28	Ch4 Upper RxD/TxD / IO 4 -	62
Ch2 Upper RxClk/TxClk / IO 5+	29	Ch4 Upper RxClk/TxClk / IO 5+	63
Ch2 Upper RxClk/TxClk / IO 5 -	30	Ch4 Upper RxClk/TxClk / IO 5 -	64
No Connect	31	No Connect	65
No Connect	32	No Connect	66
No Connect	33	No Connect	67
No Connect	34	No Connect	68

Table 5-1: Front Edge User Cable Pin-Out

P2, Row A	Pin #	P2, Row B	Pin #
Ch1 Upper Envelope / IO 0 +	1	Ch3 Upper Envelope / IO 0 +	33
Ch1 Upper Envelope / IO 0 -	2	Ch3 Upper Envelope / IO 0 -	4
Ch1 Lower RxD/TxD / IO 1+	3	Ch3 Lower RxD/TxD / IO 1+	35
Ch1 Lower RxD/TxD / IO 1 -	4	Ch3 Lower RxD/TxD / IO 1 -	36
GND	5	GND	37
GND	6	GND	38
Ch1 Lower RxClk/TxClk / IO 2 +	7	Ch3 Lower RxClk/TxClk / IO 2 +	39
Ch1 Lower RxClk/TxClk / IO 2 -	8	Ch3 Lower RxClk/TxClk / IO 2 -	40
Ch1 Lower Envelope / IO 3 +	9	Ch3 Lower Envelope / IO 3 +	41
Ch1 Lower Envelope / IO 3 -	10	Ch3 Lower Envelope / IO 3 -	42
Ch1 Upper RxD/TxD / IO 4 +	11	Ch3 Upper RxD/TxD / IO 4 +	43
Ch1 Upper RxD/TxD / IO 4 -	12	Ch3 Upper RxD/TxD / IO 4 -	44
GND	13	GND	45
GND	14	GND	46
Ch1 Upper RxClk/TxClk / IO 5+	15	Ch3 Upper RxClk/TxClk / IO 5+	47
Ch1 Upper RxClk/TxClk / IO 5 -	16	Ch3 Upper RxClk/TxClk / IO 5 -	48
Ch2 Upper Envelope / IO 0 +	17	Ch4 Upper Envelope / IO 0 +	49
Ch2 Upper Envelope / IO 0 -	18	Ch4 Upper Envelope / IO 0 -	50
Ch2 Lower RxD/TxD / IO 1+	19	Ch4 Lower RxD/TxD / IO 1+	51
Ch2 Lower RxD/TxD / IO 1 -	20	Ch4 Lower RxD/TxD / IO 1 -	52
GND	21	GND	53
GND	22	GND	54
Ch2 Lower RxClk/TxClk / IO 2 +	23	Ch4 Lower RxClk/TxClk / IO 2 +	55
Ch2 Lower RxClk/TxClk / IO 2 -	24	Ch4 Lower RxClk/TxClk / IO 2 -	56
Ch2 Lower Envelope / IO 3 +	25	Ch4 Lower Envelope / IO 3 +	57
Ch2 Lower Envelope / IO 3 -	26	Ch4 Lower Envelope / IO 3 -	58
Ch2 Upper RxD/TxD / IO 4 +	27	Ch4 Upper RxD/TxD / IO 4 +	59
Ch2 Upper RxD/TxD / IO 4 -	28	Ch4 Upper RxD/TxD / IO 4 -	60
GND	29	GND	61
GND	30	GND	62
Ch2 Upper RxClk/TxClk / IO 5+	31	Ch4 Upper RxClk/TxClk / IO 5+	63
Ch2 Upper RxClk/TxClk / IO 5 -	32	Ch4 Upper RxClk/TxClk / IO 5 -	64

Table 5-2: Rear IO PMC P4 Pin-Out

5.4 Termination Resistors

The RS485/RS422 cable interface requires termination of the differential signals to match the cable impedance. The PMC-SIO4AR is shipped with 150 Ohm termination resistor SIPs. These resistors are socketed so they can be changed or removed as necessary. There are six termination resistors – RP1 through RP6. The termination resistors are standard 8-pin isolated resistor SIPs (four resistors per SIP). Refer to Figure 5.1-1 for resistor pack locations.

CHAPTER 6: ORDERING OPTIONS

6.0 Ordering Information

Since the PMC-SIO4AR is designed to fit a variety of high-speed serial interface needs, there are several options that must be specified when ordering the PMC-SIO4AR board. Please consult our sales department with your application requirements to determine the correct ordering option. (sales@generalstandards.com).

6.0.1 FIFO Size

The SIO4 can accept FIFOs with depths ranging from 512 bytes to 32k bytes. Larger FIFO depth is important for faster interfaces to reduce the risk of data loss due to software overhead. The PMC-SIO4AR can be ordered with the following FIFO depths: 512 bytes, 1kbytes, 2kbytes, 4kbytes, 8kbytes, 16kbytes, or 32kbytes. Note that the FIFO size option in the board part number refers to the total FIFO size for all 8 channels, not the FIFO size of a single FIFO. For example, PMC-SIO4AR-8K would contain eight 1k deep FIFOs. Please consult our sales department for pricing and availability.

6.0.2 Interface Cable

General Standards Corporation can provide an interface cable for the PMC-SIO4AR board. This standard cable is a non-shielded twisted pair ribbon cable for increased noise immunity. Several standard cable lengths are offered, or the cable length can be custom ordered to the user's needs. Versions of the cable are available with connectors on both ends, or the cable may be ordered with a single connector to allow the user to adapt the other end for a specific application. A standard cable is available which will breakout the serial channels into four DB25 connectors. Shielded cable options are also available. Please consult our sales department for more information on cabling options and pricing.

6.0.3 Device Drivers

General Standards has developed many device drivers for The PMC-SIO4AR boards, including VxWorks, Windows, Linux, and LabView. As new drivers are always being added, please consult our website (www.generalstandards.com) or consult our sales department for a complete list of available drivers and pricing.

6.1 Custom Applications

Although the PMC-SIO4AR board provides extensive flexibility to accommodate most user applications, a user application may require modifications to conform to a specialized user interface. General Standards Corporation has worked with many customers to provide customized versions based on the PMC-SIO4AR boards. Please consult our sales department with your specifications to inquire about a custom application.

APPENDIX A: COMMON PROGRAMMABLE CLOCK REGISTER VALUES

The following table lists the Programmable Clock Register Values for common clock frequencies.

Transmit Clock Frequency	Programmable Clock Value	Post Divide Value	Programmable Oscillator Frequency
10 MHz	00129128	0	20 MHz
9.216 MHz	002D9310	0	18.432 MHz
9 MHz	00109120	0	18 MHz
8 MHz	000E9120	0	16 MHz
7.5 MHz	000D9120	0	15 MHz
7.3728 MHz	00351480	0	14.7456 MHz
6 MHz	00169928	0	12 MHz
5.5295 MHz	00381B28	0	11.059MHz
5 MHz	00129928	0	10 MHz
4 MHz	000E9928	0	8 MHz
3.6864 MHz	002A1B90	0	7.3728MHz
3 MHz	0016A128	0	6 MHz
2.5 MHz	0012A128	0	5 MHz
2 MHz	000EA120	0	4 MHz
1.8432 MHz	002A2390	0	3.6864MHz
1 MHz	000EA920	0	2 MHz
921.6 kHz	00372CB0	0	1.8432MHz
500 kHz	000EB120	0	1 MHz
460.8 kHz	002A3390	0	921.6kHz
250 kHz	000EB920	0	500 kHz
230.4 kHz	002A3B90	0	460.8kHz
125 kHz	0210EB920	2	500 kHz
115.2 kHz	022A3B90	2	460.8kHz
57.6 kHz	042A3B90	4	460.8kHz
50 kHz	050EB920	5	500 kHz
28.8 kHz	082A3B90	8	460.8kHz
25 kHz	0A0EB920	10	500 kHz
19.2 kHz	1038BB90	16	460.8kHz
9.6 kHz	2038BB90	32	460.8kHz
5 kHz	320EB920	50	500 kHz
4.8 kHz	4038BB90	64	460.8kHz
2.5 kHz	640EB920	100	500 kHz
2.4 kHz	8038BB90	128	460.8kHz
1.25 kHz	C80EB920	200	500 kHz
1.2 kHz	0838BB90	200	480kHz
1 kHz	C80EB970	200	400kHz

APPENDIX B: CALCULATING PROGRAMMABLE CLOCK VALUES

The values in Appendix A were derived using the BitCalc program from Cypress Semiconductor for an ICD2053B with an input clock frequency of 20MHz. The actual transmit clock/data speed will be one half the frequency of the programmable oscillator. The correct BitCalc value to use is referred to as the “Hex word (Unstuffed)”. If a desired clock frequency is less than 400kHz (min frequency of programmable oscillator), the FPGA post divider (D31:D24) may be used to further reduce the clock. The programmable oscillator frequency will be set to a multiple of the desired frequency which is greater than 400kHz. Using this method, you should be able to achieve any frequency between 20MHz and 1.57kHz (400kHz / 255). If frequencies slower than 1.57kHz are required, the baud rate generators of the USC may also be used.

EXAMPLE:

To obtain a frequency of 9600Hz *.

Since $9600 < 400k$, we will need to use the post-divider. Choose a post divide value to obtain a programmable oscillator frequency greater than 400kHz. For a value of 64 (0x40):

$$9600 * 64 = 614400\text{Hz}$$

So the on-board programmable oscillator will be set at 614.4kHz, and post-divider will be set to 64 to get clock frequency of 9600.

Using BitCalc with Reference Frequency of 20MHz and a Desired frequency of 0.6144MHz

Hex Word (Unstuffed) = 0x38BB90

Post divide: 64 (0x40)

Programmable Clock Register Word = 0x4038BB90

D23:D0 = 0x38BB90

D31:D24 = 0x40

Using the above method, you should be able to achieve any input clock frequency between 20MHz and 1.57kHz (400kHz / 255). If frequencies slower than 1.57kHz are required, the USC internal baud rate generator may be used to further divide the clock. Remember that asynchronous protocols oversample at 16x / 32x /or 64x the input clock frequency, so async baud rates below 30Hz are possible without using the USC internal baud rate generators.

If different clock frequencies are required for each channel, the programmable oscillator should be set to a common multiple of the desired frequencies. Since there is only a single programmable oscillator, the different frequencies are determined by different post-divider values.

* The actual transmit clock/data speed will be one half the frequency of the programmable oscillator.