

General Standards Corporation
High Performance Bus Interface Solutions

Rev: 082507

PMC66-16AISS16AO2

18-Channel 16-Bit PMC Analog Input/Output Board

*With 16 Simultaneously-Sampled Inputs at 1.0 MSPS per Channel,
Two Analog Outputs at 1.0 MSPS per Channel,
And 6-Bit Digital I/O Port*

REFERENCE MANUAL

Revised for Demand Mode DMA operation

TABLE OF CONTENTS

SECTION	TITLE	PAGE
1.0	INTRODUCTION	1-1
2.0	INSTALLATION AND MAINTENANCE	2-1
2.1	Board Configuration	2-1
2.2	Installation	2-1
2.2.1	Physical Installation	2-1
2.2.2	Input/Output Cable Connections	2-2
2.3	System Configuration	2-3
2.3.1	Analog Inputs	2-3
2.3.1.1	Differential Inputs	2-3
2.3.1.2	Single-Ended Inputs	2-4
2.3.2	Analog Outputs	2-5
2.3.2.1	Output Configurations	2-5
2.3.2.2	Loading Considerations	2-5
2.3.3	External Sync I/O	2-6
2.3.4	Multiboard Synchronization	2-7
2.4	Maintenance	2-7
2.5	Reference Verification	2-7
2.5.1	Equipment Required	2-8
2.5.2	Verification and Adjustment	2-8
3.0	CONTROL SOFTWARE	3-1
3.1	Introduction	3-1
3.2	Board Control Register (BCR)	3-2
3.3	Configuration and Initialization	3-2
3.3.1	Board Configuration	3-2
3.3.2	Initialization	3-2
3.4	Analog Inputs	3-4
3.4.1	Input Modes	3-4
3.4.1.1	System Inputs	3-4
3.4.1.2	Test Modes	3-5

TABLE OF CONTENTS (Continued)

SECTION	TITLE	PAGE
3.4.2	Active Channels Selection	3-5
3.4.3	Input Ranges	3-5
3.4.4	Sampling Modes	3-6
3.4.4.1	Continuous	3-6
3.4.4.2	Burst Sampling	3-6
3.4.5	Input Data Buffer	3-7
3.4.5.1	Organization	3-7
3.4.5.2	Buffer Size and Threshold Registers	3-8
3.5	Analog Input Buffer DMA Operation	3-8
3.5.1	Block Mode	3-8
3.5.2	Demand Mode	3-8
3.6	Data Coding Formats	3-9
3.7	Rate-A/B Generators	3-10
3.8	Multiboard Synchronization	3-10
3.9	Digital I/O Port	3-11
3.10	Autocalibration	3-12
3.11	Primary Status Register	3-12
3.12	Registered Analog Outputs	3-13
3.12.1	Output Ranges	3-14
3.12.2	Clocking Modes	3-14
3.12.2.1	Immediate	3-14
3.12.2.2	Simultaneous	3-14
3.13	Buffered Analog Output Control	3-15
3.13.1	Data Organization	3-16
3.13.1.1	Active Channels	3-16
3.13.1.1.1	Selection	3-16
3.13.1.1.2	Loading	3-16
3.13.1.2	Data Frame	3-18
3.13.1.3	Voltage Range Selection	3-18
3.13.2	Output Buffer	3-18
3.13.2.1	Output Data Format	3-18
3.13.2.2	Output Data Coding	3-19

TABLE OF CONTENTS (Continued)

SECTION	TITLE	PAGE
3.13.2.3	Output Buffer Control	3-19
3.13.2.4	Open Buffer	3-20
3.13.2.5	Circular Buffer	3-20
3.13.3	Function Generation	3-21
3.13.3.1	Periodic and One-Shot Functions	3-21
3.13.3.2	Multiple Functions	3-21
3.13.3.3	Function Sequencing (Concatenation)	3-21
3.13.4	Output Clocking	3-23
3.13.4.1	Clock Source	3-23
3.13.4.1.1	External Clock	3-23
3.13.4.1.2	Internal Output Rate Generator	3-23
3.13.4.2	Simultaneous Clocking	3-24
3.13.4.3	Sequential Operation	3-24
3.13.5	Sampling Mode	3-24
3.13.5.1	Continuous Sampling	3-24
3.13.5.2	Data Bursts	3-24
3.13.6	Multiboard Synchronization	3-25
3.13.6.1	Synchronous Bursts	3-25
3.13.6.2	Synchronous Clocking	3-25
3.14	Buffered Analog Output Application Examples	3-26
3.14.1	Sequential Direct Outputs	3-27
3.14.2	Simultaneous Direct (Single Group) Outputs	3-28
3.14.3	Continuous Function	3-29
3.14.4	Periodic Function	3-30
3.14.5	Function Burst	3-31
3.14.6	Function Sequencing	3-33
3.15	Analog Output Buffer DMA Operation	3-34
3.15.1	Block Mode	3-34
3.15.2	Demand Mode	3-34
3.16	Assembly Configuration Register	3-35
4.0	PRINCIPLES OF OPERATION	4-1
4.1	General Description	4-1
4.2	Analog Inputs	4-2
4.3	Input Data Buffer	4-2
4.4	Analog Outputs	4-2
4.5	Autocalibration	4-2
4.6	Power Control	4-3
App A	Local Register Quick Reference	A-1
App B	Comparison of PMC66-16AISS16AO2 and PMC66-16AISS8AO4	B-1

LIST OF ILLUSTRATIONS

FIGURE	TITLE	PAGE
1.1-1	Functional Organization	1-1
2.2-1	PMC Physical Installation	2-1
2.2-2	System I/O Connector	2-3
2.3-1	Analog Input Configurations	2-4
2.3-2	Output Configurations	2-5
2.3-3	Line Loss versus Load Current	2-6
2.3-4	Multiboard Synchronization	2-7
2.5-1	Reference Adjustment Access	2-8
3.6-1	Analog Data Coding Formats; 16-Bit Data	3-9
3.13-1	Typical Buffer Loading Sequence	3-16
3.13-2	Open Buffer Data Flow	3-20
3.13-3	Circular Buffer Data Flow	3-21
3.13-4	Function Sequencing	3-22
4.1-1	Functional Block Diagram	4-1

LIST OF TABLES

TABLE	TITLE	PAGE
2.2-1	System I/O Connector Pin Functions	2-2
2.5-1	Reference Verification Equipment	2-8
3.1-1	Control and Status Registers	3-1
3.2-1	Board Control Register (BCR)	3-3
3.3-1	Configuration Operations	3-4
3.4-1	Active Input Channels Register	3-5
3.4-2	Input Data Buffer	3-7
3.4-3	Input Buffer Threshold Register	3-8
3.5-1	Typical Input DMA Register Configuration; Block Mode	3-8
3.5-2	Typical Input DMA Register Configuration; Demand Mode	3-9
3.7-1	Analog Input and Trigger Rate Generator Registers (A, B)	3-10
3.7-2	Input Rate Generator Frequency Selection	3-10
3.9-1	Digital I/O Port Register	3-11
3.11-1	Primary Status Register	3-13
3.12-1	Analog Output Channel Data Register	3-13
3.12-2	Simultaneous Output Clock Source Selection	3-14
3.13-1	Summary of Buffered Output Control Parameters	3-15
3.13-2	Buffered Output Operations Register	3-17
3.13-3	Analog Output Buffer	3-18
3.13-4	Output Buffer Size Register	3-19
3.13-5	Output Buffer Threshold Register	3-19
3.13-6	Output Sample Rate Control Register (Rate-C)	3-23
3.13-7	Output Sample Rate Selection	3-24
3.14-1	Summary of Operation Examples	3-26
3.14-2	Initial Operations	3-26
3.14-3	Sequential Direct Outputs Example	3-27
3.14-4	Simultaneous Direct Outputs Example	3-28
3.14-5	Continuous Function Example	3-29
3.14-6	Periodic Function Example	3-30
3.14-7	Function Burst Example	3-31
3.14-8	Function Sequencing Example	3-33
3.15-1	Typical Output DMA Register Configuration; Block Mode	3-34
3.15-2	Typical Output DMA Register Configuration; Demand Mode	3-34
3.16-1	Assembly Configuration Register	3-35

PMC66-16AISS16AO2

SECTION 1.0 INTRODUCTION

The single-width PCI mezzanine card PMC66-16AISS16AO2 provides 16-bit analog input and output capability for PMC applications. 16 analog input channels (Figure 1.1-1) are digitized simultaneously at rates up to 1,000,000 conversions per second per channel, with software-controlled voltage ranges of $\pm 10V$, $\pm 5V$ or $\pm 2.5V$. Digitized input data is buffered through a 256K-sample FIFO.

Two 16-bit analog output channels provide software-selected output ranges of $\pm 10V$, $\pm 5V$ or $\pm 2.5V$, and are accessed either directly through dedicated control registers, or through a 256K-sample FIFO buffer. The analog output buffer can be clocked at rates up to 1,000,000 output samples per second per channel.

A 6-Bit digital port is configured as six independently controlled bidirectional I/O lines.

The board is designed for minimum off-line maintenance. All functional parameters are under software control, thereby eliminating field-configuration jumpers. A selftest switching network routes output channels or calibration reference signals to the analog inputs, and permits board integrity to be verified by the host.

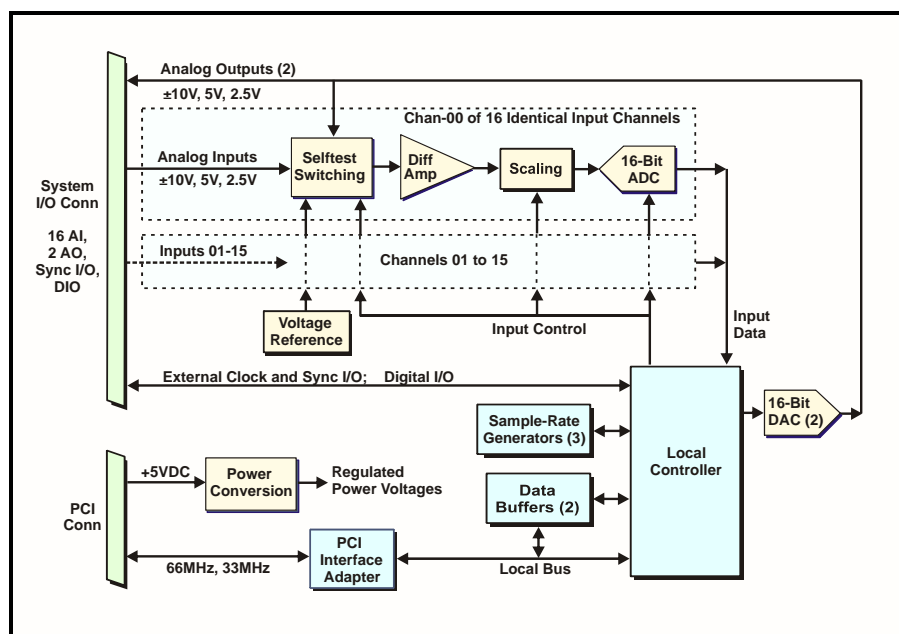

Figure 1.1-1. Functional Organization

This product is functionally compatible with the IEEE PCI local bus specification Revision 2.3, and supports the "plug-n-play" initialization concept. System connections are made at the front panel through a high-density dual-ribbon 80-pin connector. Electrical power is derived from +5VDC supplied by the PCI bus, and analog power voltages are generated internally. Universal signaling is supported, and all operational parameters are software configurable. Operation over the specified temperature range is achieved with conventional convection cooling.

PMC66-16AISS16AO2

SECTION 2.0

INSTALLATION AND MAINTENANCE

2.1 Board Configuration

This product has no field-alterable configuration features, and is completely configured at the factory for field use.

2.2 Installation

2.2.1 Physical Installation

To minimize the opportunity for accidental damage before installation, the board should be stored in the original protective shipping envelope. System power must be turned OFF before proceeding with the installation.

CAUTION: This product is susceptible to damage from electrostatic discharge (ESD). Before removing the board from the conductive shipping envelope, ensure that the work surface, the installer and the host board have been properly discharged to ground.

After removing the board from the shipping envelope, position the board with the shield and standoffs facing the host (carrier) board, and with the I/O connector oriented toward the front panel (Figure 2.2-1). Align the two PCI connectors located at the end of the board opposite the I/O connector, with the mating connectors on the host board. Then carefully press the board into position on the host. Verify that the PCI connectors have mated completely and that the standoffs are seated against the host board.

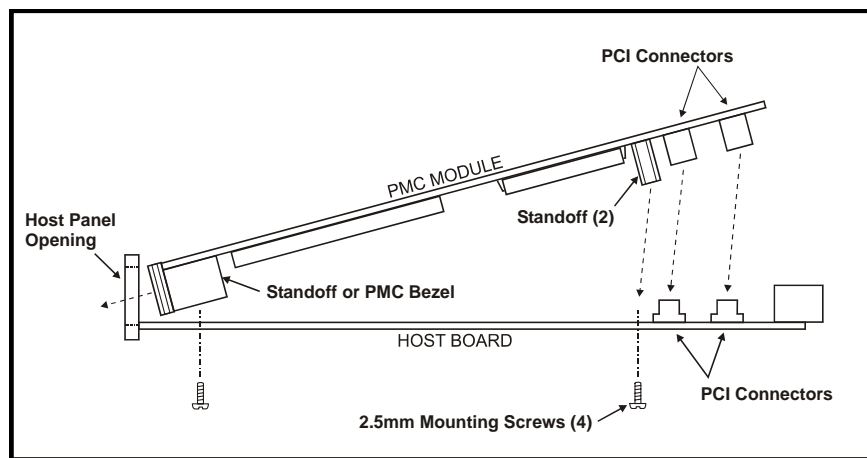

Figure 2.2-1: PMC Physical Installation

Attach the board to the host with four 2.5 x 6.5mm panhead screws. Pass the screws through the back of the host into the four mounting holes on the board. Tighten the screws carefully to complete the installation. Do not overtighten.

2.2.2 Input/Output Cable Connections

System cable signal pin assignments are listed in Table 2.2-1. The I/O connector is designed to mate with an 80-pin dual-ribbon connector, equivalent to Robinson Nugent #P50E-080S-TG. The Robinson Nugent insulation displacement connector accepts two 40-wire 0.050-inch ribbon cables, with the pin numbering convention shown in Table 2.2-1 and in Figure 2.2-2. Contact the factory if preassembled cables are required.

Table 2.2-1. System I/O Connector Pin Functions

ROW-A		ROW-B	
PIN	SIGNAL	PIN	SIGNAL
1	INP00 LO *	1	INP10 LO **
2	INP00 HI *	2	INP10 HI **
3	INPUT RTN	3	INPUT RTN
4	INPUT RTN	4	INPUT RTN
5	INP01 LO *	5	INP11 LO **
6	INP01 HI *	6	INP11 HI **
7	INPUT RTN	7	INPUT RTN
8	INPUT RTN	8	INPUT RTN
9	INP02 LO **	9	INP12 LO *
10	INP02 HI **	10	INP12 HI *
11	INPUT RTN	11	INPUT RTN
12	INPUT RTN	12	INPUT RTN
13	INP03 LO **	13	INP13 LO *
14	INP03 HI **	14	INP13 HI *
15	INPUT RTN	15	INPUT RTN
16	INPUT RTN	16	INPUT RTN
17	INP04 LO *	17	INP14 LO **
18	INP04 HI *	18	INP14 HI **
19	INPUT RTN	19	INPUT RTN
20	INPUT RTN	20	INPUT RTN
21	INP05 LO *	21	INP15 LO **
22	INP05 HI *	22	INP15 HI **
23	INPUT RTN	23	OUTPUT RTN
24	INPUT RTN	24	ANA OUT 01
25	INP06 LO **	25	DIGITAL RTN
26	INP06 HI **	26	DIO 00
27	INPUT RTN	27	DIGITAL RTN
28	INPUT RTN	28	DIO 01
29	INP07 LO **	29	DIGITAL RTN
30	INP07 HI **	30	DIO 02
31	INPUT RTN	31	DIGITAL RTN
32	INPUT RTN	32	DIO 03
33	INP08 LO *	33	DIO 04
34	INP08 HI *	34	DIO 05
35	INPUT RTN	35	DIGITAL RTN
36	INPUT RTN	36	OUTPUT CLK I/O
37	INP09 LO *	37	DIGITAL RTN
38	INP09 HI *	38	TRIGGER I/O
39	OUTPUT RTN	39	DIGITAL RTN
40	ANA OUT 00	40	INPUT CLK I/O

* Input Group-A. ** Input Group-B.
The 8 input-channel configuration contains input Channels 00-07.

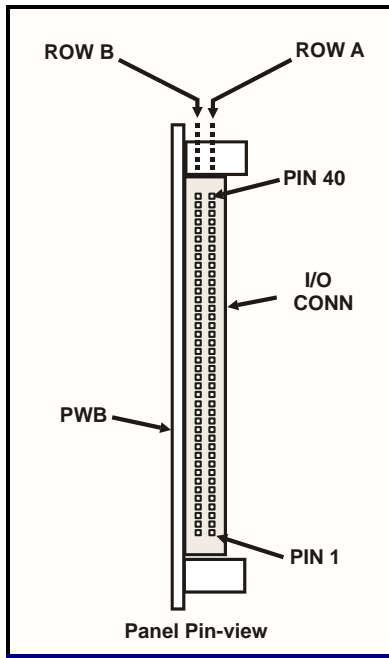

Figure 2.2-2. System I/O Connector

2.3 System Configuration

2.3.1 Analog Inputs

The 16 analog input channels can be configured for either differential or single-ended operation. The hardware input configuration must be acknowledged by the control software.

2.3.1.1 Differential Inputs

Differential input operation usually provides the best performance, and is essential when the input signal sources are not isolated from each other or have returns that are at significantly different potentials. A potential difference between grounds is significant if it is larger than the maximum tolerable measurement error.

This operating mode also offers the highest rejection of the common mode noise, which is a characteristic of long cables in typical instrumentation environments. When operating in the differential mode, shown in Figure 2.3-1a, the wire pair from each signal source is connected between the HI(+) and LO(-) inputs of a single input channel. The input return (INPUT RTN in Table 2.2-1) is connected to a ground point which ensures that the sum of the signal level (**V_{sig}**) and the common mode voltage (**V_{cm}**) remains within the range specified for the board. Ground current through the INPUT RTN pins must be limited in order to avoid damage to the cable or the input board.

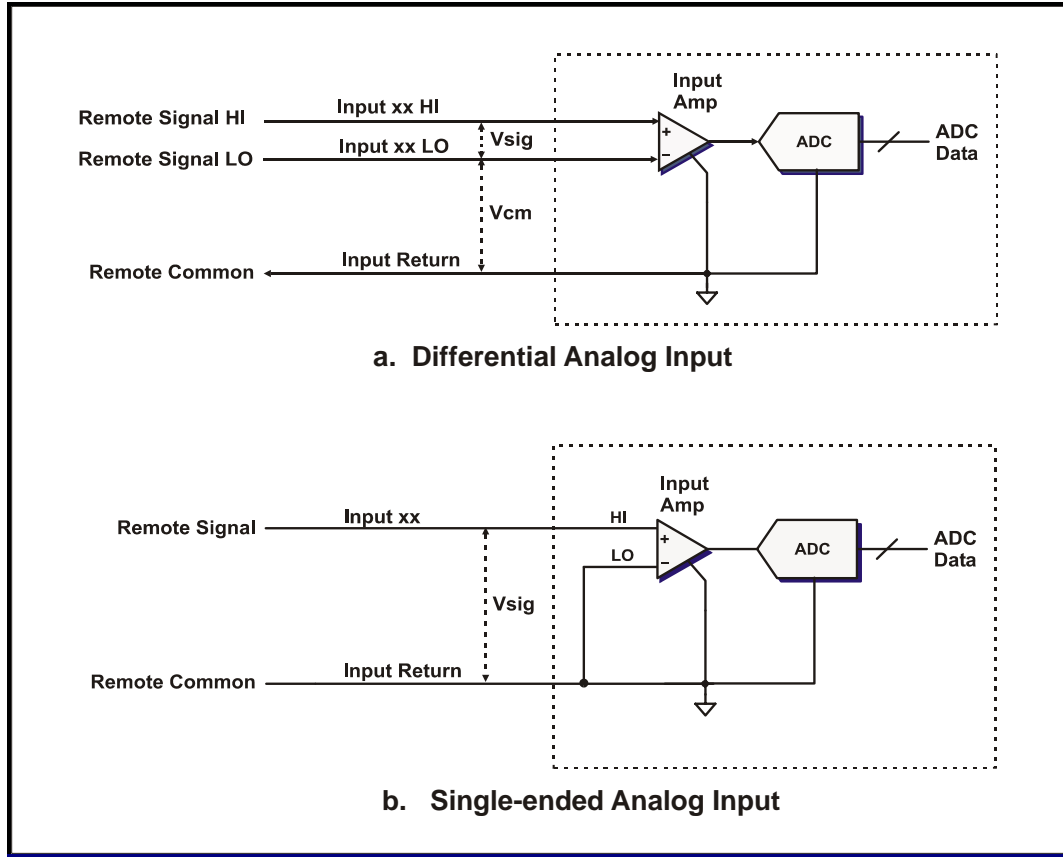

Figure 2.3-1. Analog Input Configurations

2.3.1.2 Single-Ended Inputs

Single-ended operation (Figure 2.3-1b) generally provides acceptable performance only when the input signal sources either are isolated from each other, or are common to a single isolated signal return. A single-ended configuration usually is more susceptible to system interference than a differential configuration.

Single-ended inputs share a common input return that provides a return path for all inputs, making isolation from other system grounds a critical issue. If the signal sources are returned externally to system ground when operating in this mode, a potential difference between the system ground and input return can cause erroneous measurements, or could generate potentially destructive ground current.

For applications in which multiple signal sources share a single ground, the differential configuration is recommended, with all "LO" inputs connected together at the common remote return.

2.3.2 Analog Outputs

2.3.2.1 Output Configurations

The two analog output channels are single-ended and have a common signal return that is referred to in Table 2.2-1 as OUTPUT RTN. Single-ended outputs should drive only loads that have high impedances to system ground. The best results are obtained when the loads are isolated also from each other.

Figure 2.3-2 shows the primary sources of error in both isolated and nonisolated system configurations. For loads that are isolated from each other (Figure 2.3-2a), the total line-loss error is twice the loss produced in a single line, assuming equal wire size and length for output and return lines. For loads with a common return that is isolated from system ground, line loss in the common return appears as crosstalk between channels.

If the load return is connected to a remote system ground (Figure 2.3-2b), the potential difference **V_{gnd}** between the remote ground and the internal signal return will introduce an error into the signal delivered to the load. The ground current **I_{gnd}** developed in the return line is limited essentially only by **R_{gnd}**, and can damage the cable or the board if not controlled.

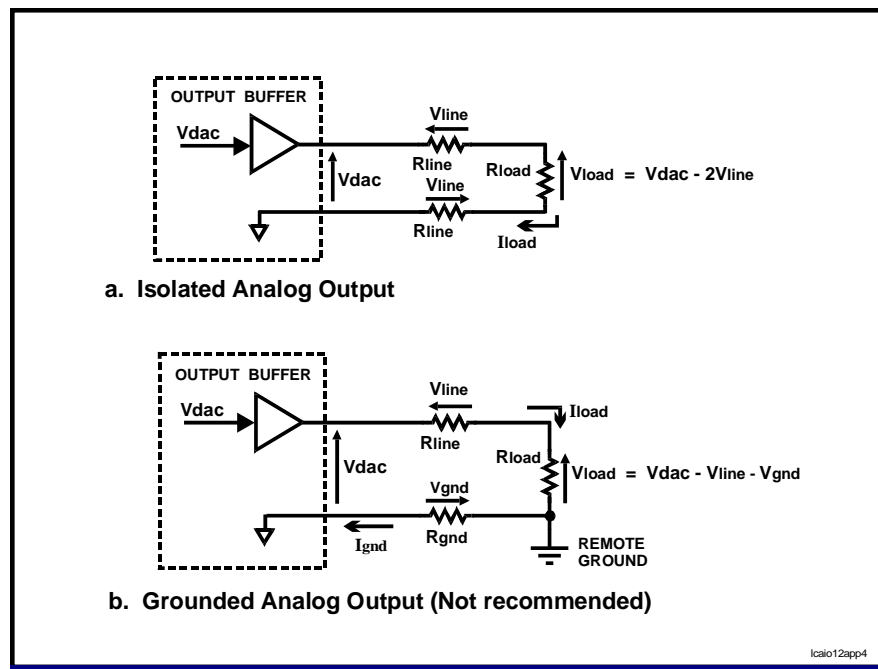

Figure 2.3-2. Output Configurations

2.3.2.2 Loading Considerations

The voltage drop in the system I/O cable can be a significant source of error, especially with relatively long cables driving moderate or heavy loads. Figure 2.3-3 shows the effect of load current on the voltage drop in copper wire of various sizes. A 4.0 milliamp load for example, inserts a voltage drop of more than 0.25 millivolt *per foot* in #28 AWG ribbon cable; twice that if the return line also is considered. Several feet of ribbon cable therefore can produce significant errors, especially in a 16-bit system, in which 1 LSB can represent

only 76 microvolts on a ± 2.5 Volt range. High impedance loads generally do not produce significant DC errors.

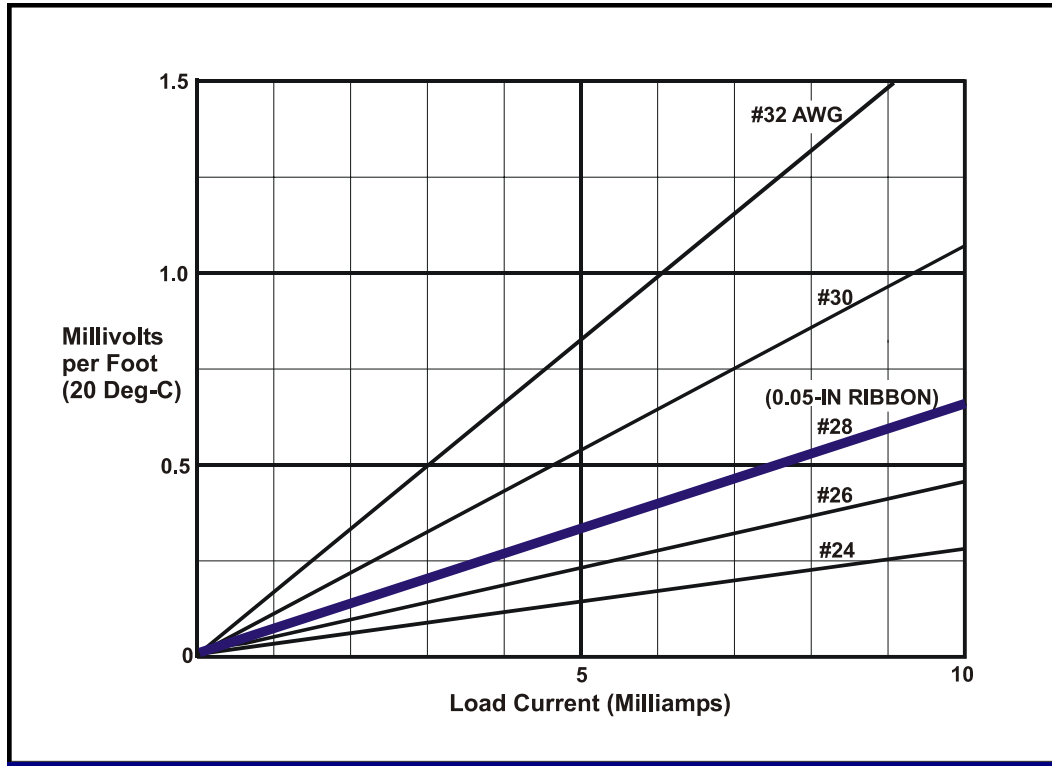

Figure 2.3-3. Line Loss versus Load Current

2.3.3 External Sync I/O

The INPUT CLK I/O and OUTPUT CLK I/O pins in the system connector are bidirectional TTL synchronization signals that provide external control of analog input sampling and analog output clocking, respectively. The TRIGGER I/O pin also is bidirectional, and is shared by the analog inputs and outputs. Specific input/output configurations are determined by individual system requirements, and must be acknowledged by the control software.

When a board is software-configured as an **Initiator**, these I/O signals are outputs that can be used to control multiple **Target** boards. Each clock or trigger event output consists of a 120 -170 nanosecond TTL pulse, asserted LOW. Output loading in the Initiator configuration should be limited to 8 milliamps or less. The analog inputs, analog outputs and triggering all can be configured independently as either initiators or targets.

For **Target** boards, the I/O signals become inputs and can synchronize input and output operations to an Initiator board. Clock and trigger inputs are edge-detected on the negative (falling) edge, and must be asserted for at least 100 nanoseconds in order to be acknowledged. All three inputs are asserted LOW, and are pulled up internally to +3.3V through approximately 33 KOhms.

2.3.4 Multiboard Synchronization

If multiple boards are to be synchronized together, the INPUT CLK I/O, TRIGGER I/O and OUTPUT CLK I/O pins from one board, the *initiator*, are connected to the corresponding pins of as many as four *target* boards in the same backplane (Figure 2.3-4). The controlling software determines specific synchronization functions.

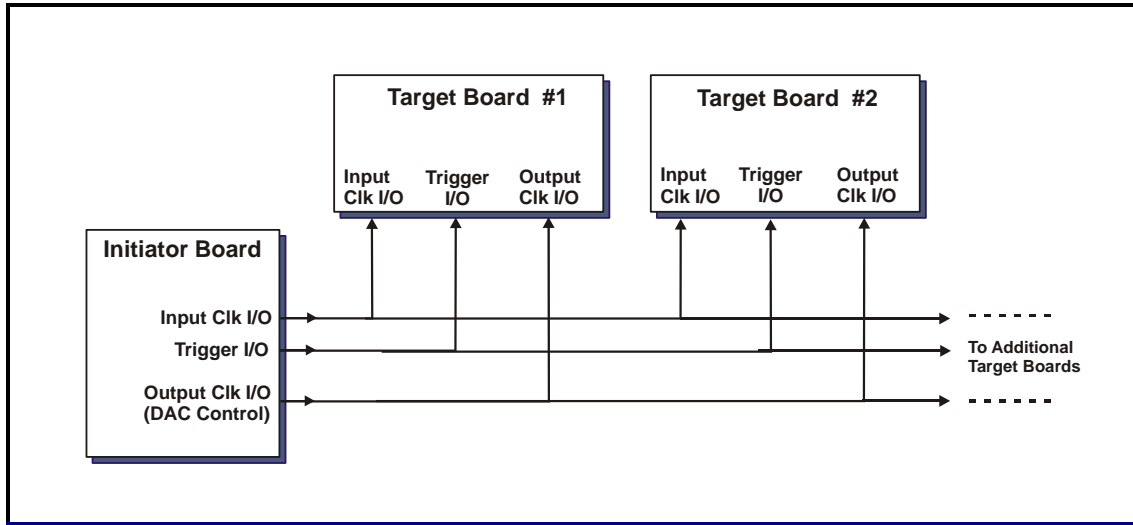

Figure 2.3-4. Multiboard Synchronization

2.4 Maintenance

This product requires no scheduled maintenance other than periodic verification and possible adjustment of the internal voltage reference. The optimum verification interval will vary with upon the specific application, but in most instances an interval of one year should be sufficient.

In the event of a suspected malfunction, all associated system parameters, such as power voltages, control bus integrity, and system interface signal levels, should be evaluated before troubleshooting of the board itself is attempted. A board that has been determined to be defective should be returned to the factory for detailed problem analysis and repair.

2.5 Reference Verification

All analog channels are software-calibrated to a single internal voltage reference by an embedded autocalibration utility. The procedure presented here describes the verification and adjustment of the reference.

2.5.1 Equipment Required

Table 2.5-1 lists the equipment required for verifying or adjusting the internal reference. Alternative equivalent equipment may be used.

Table 2.5-1. Reference Verification Equipment

EQUIPMENT DESCRIPTION	MANUFACTURER	MODEL
Digital Multimeter, 5-1/2 digit, 0.005% accuracy for DC voltage measurements at ± 10 Volts. Input impedance 10 Megohms or greater.	Hewlett Packard	34401A
Host board with single-width PMC adapter	(Existing host)	---
Test cable; suitable for connecting the digital multimeter to the system I/O connector.	---	---

2.5.2 Verification and Adjustment

The following procedure describes the verification of the internal voltage reference. Adjustment of the internal reference, if necessary, is performed with an internal trimmer that is accessible as shown in Figure 2.5-1.

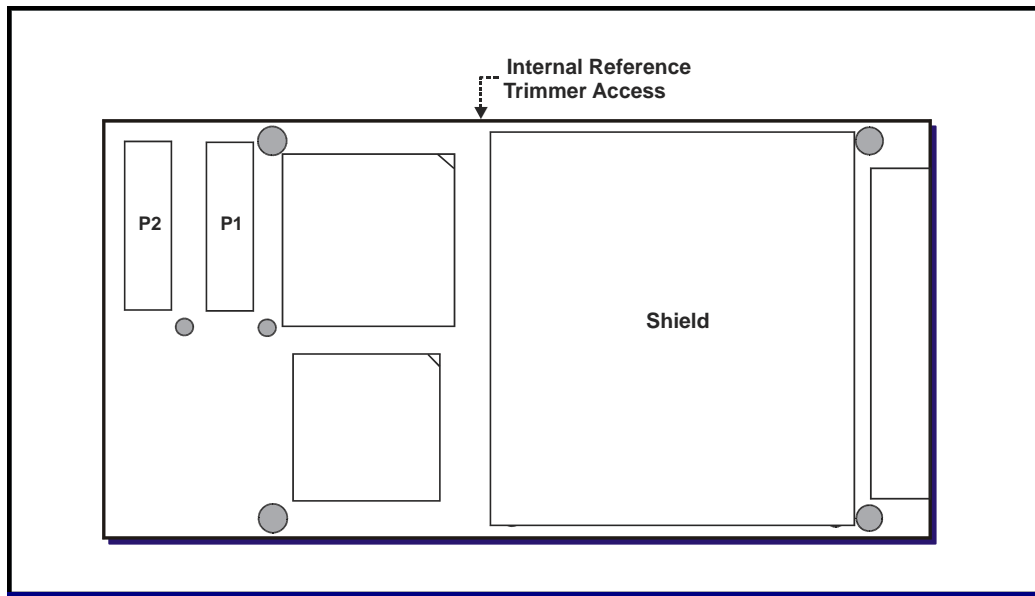

Figure 2.5-1. Reference Adjustment Access

This procedure assumes that the PMC is installed on a host board, and that the host is installed in a system.

1. Connect the digital multimeter between Pin-2 (+) and Pin-4 (-) of test connector J2, located adjacent to the trimmer.
2. If power has been removed from the board, apply power now. Wait at least 10 minutes after power is applied before proceeding..
3. Verify that the digital multimeter indication is $+9.9000 \text{ VDC} \pm 0.0015 \text{ VDC}$. If the indication is not within this range, adjust the internal reference trimmer for an in-range digital multimeter indication.
4. Verification and adjustment is completed. Remove all test connections.

PMC66-16AISS16AO2

SECTION 3.0

CONTROL SOFTWARE

3.1 Introduction

The PMC66-16AISS16AO2 board is compatible with the PCI Local Bus specification Revision 2.3, and supports auto configuration at the time of power-up. A PLX™ PCI-9056 adapter controls the PCI interface. Configuration-space registers are initialized internally to support the location of the board on any 32-longword boundary in memory space. After initialization is completed, communication between the PCI bus and the local bus takes place through the control and data registers listed in Table 3.1-1. All data transfers are long-word D32. DMA access is supported for data transfers from the analog input buffer and to the analog output data buffers. To ensure compatibility with subsequent controller revisions, reserved control bits should be written LOW (zero), and maintenance registers should not be modified.

Table 3.1-1. Control and Status Registers

OFFSET (Hex)	REGISTER	MODE	DEFAULT	PRIMARY FUNCTION	REF
0000	BOARD CONTROL	RW	2202 00A0h	Board Control Register (BCR).	3.2
0004	DIGITAL I/O PORT	RW	0000 00XXh	Digital I/O port data.	3.9
0008	ANALOG OUTPUT CHAN 00	RW	0000 8000h	Output Channel 00 data.	3.5
000C	ANALOG OUTPUT CHAN 01	RW	0000 8000h	Output Channel 01 data.	3.5
0010	(Reserved)	RO	0000 0000h	---	---
0014	ACTIVE INPUT CHANNELS	RW	0000 FFFFh	Active input channels selection mask.	3.4.2
0018	ANALOG INPUT BUFFER	RO	00XX XXXXh	Analog input buffer data.	3.4.5
001C	RATE GENERATOR A	RW	0000 007Eh	Rate-A generator divider; 24 bits.	3.7
0020	RATE GENERATOR B	RW	0000 2760h	Rate-B generator divider; 24 bits.	3.7
0024	AI BURST BLOCK SIZE	RW	0000 0400h	Analog input burst size.	3.4.4.2
0028	INPUT BUFFER SIZE	RO	0000 0000h	Number of data values in the input buffer.	3.4.5.2
002C	INPUT BUFFER THRESHOLD	RW	0003 FFFEh	Input buffer status flag threshold.	3.4.5.2
0030	PRIMARY STATUS	RW	0000 0X00h	Principal status-flag register	3.11
0034	ASSEMBLY CONFIGURATION	RO	000X XXXXh	Options and firmware revision.	3.16
0038	Autocal Values *	RW	0000 XXXXh	Autocal value readback.	---
003C	BUFFERED OUTPUT OPERATIONS	RW	0000 1043h	Buffered Analog Outputs Control	3.13.2.3
0040	OUTPUT BUFFER THRESHOLD	RW	0003 FFFEh	Output buffer status flag threshold.	3.13.2.3
0044	OUTPUT BUFFER SIZE	RO	0000 0000h	Number of data values in the output buffer.	3.13.2.3
0048	ANALOG OUTPUT BUFFER	WO	0000 0000h	Analog Output Data Buffer.	3.13.2
004C	RATE GENERATOR C	RW	0000 007Eh	Rate-C generator divider; 24 bits.	3.13.4.1.2
0050-007C	(Reserved)	---	---	---	---

* Maintenance register; Shown for reference only.

3.2 Board Control Register (BCR)

Basic board functions such as initialization, autocalibration and input/output range selection are controlled through the board control register (BCR) shown in Table 3.2-1. Specific control bits are cleared automatically after the associated operations have been completed. Read-only status flags indicate the states of specific operational functions.

3.3 Configuration and Initialization

3.3.1 Board Configuration

During *board configuration*, initial values for both the PCI configuration registers and the internal control logic are extracted from internal nonvolatile read-only memory. This process is initiated by a PCI bus reset, and should be required only once after the initial application of power. While the PCI configuration registers are being loaded, the response to PCI target accesses is RETRY's. Configuration operations are executed in the sequence shown in Table 3.3-1.

Loading of the PCI configuration registers is completed within 3 milliseconds after the assertion of a PCI bus reset.

3.3.2 Initialization

Internal control logic can be initialized without invoking a full reconfiguration by setting the INITIALIZE control bit HIGH in the BCR. This action initializes the internal logic, but does not affect the PCI configuration registers and does not reconfigure the internal control logic. Initialization requires 3 milliseconds or less for completion, and produces the following default conditions:

- The BCR is initialized; all register defaults are invoked. (Paragraph 3.3).
- Analog input and output data coding is offset binary. (3.6).
- All analog input and output channels are active. (3.4.2, 3.13.1.1.1).
- Analog input and output ranges are $\pm 10V$. (3.4.3, 3.12.1, 3.13.1.3).
- External clock and trigger signals are in the target (Input) mode. (3.8, 3.13.6).
- The input and output buffers are reset to empty. (3.4.5.1, 3.13.2.3).
- Analog Inputs:
 - Input channels are differential. (3.4.1.1).
 - Sample clocking is from the Rate-A generator; Bursting is disabled. (3.4.4.2, 3.7).
 - The ADC (Rate-A) generator is adjusted to 320 kHz, and is disabled. (3.7),
 - The analog input buffer is reset to empty; buffer threshold is 3FFFEh. (3.4.5).
 - Burst block size is 1024 (0400h). (3.4.4.2).
- Analog Outputs:
 - Analog outputs are at midrange (zero). (3.6).
 - Direct-Register access is selected. (3.12).
 - The DAC (Rate-C) generator is adjusted to 320 kHz, and is disabled. (3.13.4.1.2).
- The burst-trigger (Rate-B) generator is adjusted to 4 kHz, and is disabled. (3.7)
- The digital I/O port is configured as six input lines. (3.9).

Table 3.2-1. Board Control Register (BCR)

Offset: 0000h

Default: 2200 00A0h

BIT	MODE ¹	DESIGNATION	DEF	DESCRIPTION	REF
D00-D02	RW	ANALOG INPUT MODE (AIM)	0	Analog input mode: 0 => Differential system inputs 1 => Single-ended system inputs 2 => Zero selftest 3 => VREF selftest 4 => Output Channel 00 5 => Output Channel 01 6,7 => (Reserved)	3.4.1
D03	RW	INPUT BUFFER UNDERFLOW	0	Set HIGH if the input buffer underflows. Stays HIGH until cleared from the bus or by a board reset.	3.4.5.1
D04-D05	RW	INPUT RANGE A	2	Analog input Range-A; Channels 0,1,4,5,8,9,12,13: 0 => ±2.5V 2 => ±10V 1 => ±5V 3 => (Reserved)	3.4.3
D06-D07	RW	INPUT RANGE B	2	Analog input Range-B; Channels 2,3,6,7,10,11,14,15 0 => ±2.5V 2 => ±10V 1 => ±5V 3 => (Reserved)	3.4.3
D08	RW	INPUT S/W CLOCK ²	0	Initiates a single sample of active input channels. Overrides existing input clocking source.	3.4.4
D09	RW	ENABLE INPUT BURST	0	Enables triggered burst input acquisition.	3.4.4.2
D10	RO	INPUT BURST BUSY	0	HIGH when a triggered input burst is in progress.	3.4.4.2
D11	RW	INPUT S/W TRIGGER ²	0	Initiates a single input data burst. Overrides existing burst triggering source.	3.4.4.2
D12	RW	ENABLE INPUT BUFFER	0	Enables the analog input buffer for accepting data.	3.4.5.1
D13	RW	CLEAR INPUT BUFFER ²	0	Clears (empties) the analog input data buffer.	3.4.5.1
D14	RO	INPUT BUFFER THRESHOLD FLAG ³	0	HIGH when the number of values in the input buffer exceeds the selected buffer threshold.	3.4.5.2
D15	RW	INPUT BUFFER OVERFLOW	0	Set HIGH if the input buffer overflows. Stays HIGH until cleared from the bus or by a board reset.	3.4.5.2
D16-D17	RW	OUTPUT RANGE	2	Analog Output Voltage Range: 0 => ±2.5V 2 => ±10V 1 => ±5V 3 => (Reserved)	3.12.1 3.13.1.3
D18	RW	SIMULTANEOUS OUTPUTS	0	When HIGH, all outputs update simultaneously in response to an output clock. When LOW, each output is updated immediately when new data is received.	3.12.2.2 3.13.4.2
D19	RW	ENABLE BUFFERED OUTPUTS	0	When HIGH, enables the analog output FIFO buffer, and disables the analog output registers ANALOG OUTPUT CHAN xx.	3.12 3.13
D20	RW	OUTPUT S/W CLOCK ^{2,3}	0	Produces a single analog output clock. Overrides existing output clocking source.	3.12.2.2 3.13.4.1
D21	RW	TRIGGER INITIATOR	0	Configures the shared analog input/output hardware trigger pin as an output if HIGH, or as an input if LOW.	3.4.4.2
D22	R/W	ENABLE RATE-C GENERATOR	0	Enables the Rate-C generator for analog outputs.	3.13.4.1.2
D23	R/W	OUTPUT SW TRIGGER ³	0	Output Burst S/W Trigger.	3.13.5.2
D24	RW	ANALOG INPUT CLK INITIATOR	0	Configures the analog input I/O clock as an <i>output</i> if HIGH, or as an <i>input</i> if LOW.	3.4.4
D25	RW	OFFSET BINARY	1	Selects offset-binary analog I/O data format when HIGH, or two's complement when LOW.	3.6
D26	RW	ENABLE RATE-A GENERATOR	0	Enables the Rate-A generator for analog inputs.	3.7
D27	RW	ENABLE RATE-B GENERATOR	0	Enables the Rate-B generator for triggered bursts.	3.7
D28	RW	AUTOCAL ²	0	Initiates an autocalibration operation when asserted. Clears automatically upon completion,	3.10
D29	RO	AUTOCAL PASS	1	Set HIGH at reset or autocal initialization. A HIGH state after autocal confirms a successful calibration.	3.10
D30	R/W	ANALOG INPUT WARP MODE	0	Selects analog input warp mode.	3.7
D31	RW	INITIALIZE ²	0	Initializes the board. Sets all register defaults.	3.3.2

Notes: 1. RW = Read/Write, RO = Read-Only. 2. Clears automatically. 3. Duplicated elsewhere

Table 3.3-1. Configuration Operations

Operation	Maximum Duration
PCI configuration registers are loaded from internal ROM	3 ms
Internal control logic is configured from internal ROM	300 ms
Internal control logic is initialized	3 ms

3.4 Analog Inputs

Each of 16 analog input channels can be digitized simultaneously with 16-bit resolution at rates from DC to 1 Megasamples per second. Data from any combination of inputs can be acquired in a 256 Ksample buffer, and a tag-bit is attached to the first (lowest-numbered) active channel data values. Three voltage ranges are available, and any two of these ranges can be used simultaneously on different channels. Each input channel contains a dedicated 16-Bit ADC.

All active inputs are sampled simultaneously, and the sample clock can be derived: (a) from an internal rate generator, (b) from an external hardware clock input, or (c) directly from the bus.

To illustrate the requirements for initiating analog input acquisition directly after board initialization, setting the following control bits HIGH simultaneously in the BCR would start 16-channel acquisition using the Rate-A generator at the default sample rate:

- ANALOG INPUT CLK INITIATOR; Selects the analog input clock initiator mode,
- ENABLE INPUT BUFFER; Enables the analog input buffer,
- ENABLE RATE-A GENERATOR: Enables the Rate-A generator.

3.4.1 Input Modes

An input switching network routes either the system input signals or internal test signals through the input channels, and is controlled by the ANALOG INPUT MODE control field in the BCR. The system inputs are disconnected when internal signals are monitored, and have no effect on test results.

3.4.1.1 System Inputs

Of the eight possible input modes available through the ANALOG INPUT MODE field, two are dedicated to system inputs. In the differential configuration, the signal present between the HI and LO inputs in each channel is acquired. For a single-ended input, the input signal is measured between the HI input and the input return, and the LO input is ignored. The selected system input configuration must agree with the system wiring configuration (Paragraph 2.3).

3.4.1.2 Test Modes

Internal analog nodes can be monitored to verify the functional integrity of the board. The selected input ranges apply in all input modes, including test modes. The following signals are present in *all input channels* when the indicated test modes are selected:

- Zero Selftest: Midscale value, ideally equal to 0.000 VDC,
- VREF Selftest: Internal voltage reference, ideally equal to +99.00 percent of the **selected analog output range***,
- Output Channels: Either of the two analog output channels.

* The VREF Selftest source and the Output DAC's share a common reference.

3.4.2 Active Channel Selection

Input channels are designated as active by setting the corresponding ENABLE CHANNEL XX control bit HIGH in the Active Inputs control register (Table 3.4-1), or as inactive by clearing the bit LOW. All active inputs are sampled simultaneously when a sample clock occurs. Inactive channels produce no data in the input buffer.

Table 3.4-1. Active Input Channels Register

Offset: 0014h

Default: 0000 FFFFh

BIT	MODE	CHANNEL-ENABLE	DEF	DESCRIPTION
D00	RW	INPUT 00	1	Analog input channel selection mask.
D01	RW	INPUT 01	1	
D02	RW	INPUT 02	1	
D03	RW	INPUT 03	1	
D04	RW	INPUT 04	1	
D05	RW	INPUT 05	1	
D06	RW	INPUT 06	1	
D07	RW	INPUT 07	1	
D08	RW	INPUT 08	1	
D09	RW	INPUT 09	1	
D10	RW	INPUT 10	1	
D11	RW	INPUT 11	1	
D12	RW	INPUT 12	1	
D13	RW	INPUT 13	1	
D14	RW	INPUT 14	1	
D15	RW	INPUT 15	1	
D16-D31	RO	(Reserved)	0000h	

3.4.3 Input Ranges

Input voltage ranges of $\pm 10V$, $\pm 5V$ and $\pm 2.5V$ are assigned independently to two groups of input channels by the INPUT RANGE A and INPUT RANGE B control fields in the BCR:

Range A: Input channels 00, 01, 04, 05, 08, 09, 12, 13.

Range B: Input channels 02, 03, 06, 07, 10, 11, 14, 15.

Note: Voltage levels outside the selected ranges will produce saturation codes of plus or minus fullscale, but will not damage the inputs if they are within the range indicated in the product specification for overvoltage protection.

3.4.4 Sampling Modes

All active channels are sampled at each occurrence of the analog input sample clock. If the ANALOG INPUT CLK INITIATOR control bit is HIGH in the BCR, input sample clocks are supplied by either the Rate-A generator or by the INPUT S/W CLOCK control bit in the BCR. The INPUT S/W CLOCK control bit always produces an input clock, regardless of the state of the Rate-A generator or the INITIATOR control bit. In the *Initiator* mode, each sample clock produces a LOW output pulse at the bidirectional INPUT CLK I/O pin in the system I/O connector.

If the INITIATOR control bit is LOW, designating the board as a **Target**, the INPUT CLK I/O pin becomes an input, and a sample clock is generated for each HIGH-to-LOW transition received at the pin. The Rate-A generator is ignored in the target clocking mode.

To avoid contention among multiple boards interconnected for multiboard synchronous operation, the INITIATOR control bit defaults LOW for target mode.

3.4.4.1 Continuous

During continuous sampling, all active input channels are sampled continuously as long as a clock source is present. Continuous sampling is selected when the ENABLE INPUT BURST control bit is LOW in the BCR.

3.4.4.2 Burst Sampling

If burst sampling is enabled by setting the ENABLE INPUT BURST control bit HIGH in the BCR, an input trigger initiates the acquisition of a specific number of samples for each active channel. During a burst, sampling proceeds at the selected input sample rate until the specified number of samples has been acquired. Sampling then terminates until a subsequent trigger occurs. The number of samples acquired during a triggered burst is specified by the 24-Bit AI Burst Block Size control register (Table 3.1-1). The number of samples acquired in a burst *for each active channel* equals the value contained in this register. The total number of samples acquired equals this value *times* the number of active channels.

Note: If a BURST BLOCK SIZE of zero is selected while bursting is enabled, a burst trigger initiates a nonterminating burst that continues until either the sample clock is disabled or the output buffer goes empty.

The END OF BURST status bit in the input buffer (Paragraph 3.4.5) is set HIGH for the last input value acquired in a burst. The INPUT BURST BUSY status flag in the BCR is HIGH during each triggered burst, and is LOW otherwise. *Input triggering cannot occur when INPUT BURST READY is LOW.*

If the TRIGGER INITIATOR control bit in the BCR is HIGH, the board is a trigger *initiator*, and a burst trigger is provided either by the Rate-B generator or by the INPUT S/W TRIGGER control bit in the BCR. The INPUT S/W TRIGGER bit always produces a burst trigger, regardless of the state of the Rate-B generator or the INITIATOR control bit. In the *Initiator* mode, each burst trigger produces a LOW output pulse at the bidirectional TRIGGER I/O pin in the system I/O connector.

If the TRIGGER INITIATOR control bit is LOW (default), indicating *Target Mode*, the TRIGGER I/O pin becomes an input, and a trigger is generated for each HIGH-to-LOW transition received at the pin. The Rate-B generator is ignored in the target clocking mode, but the INPUT S/W TRIGGER control bit remains active.

NOTE: If TRIGGER INITIATOR is HIGH (initiator mode), the TRIGGER I/O pin is an output and produces a trigger pulse in response to either an input trigger or an output trigger (3.13.5.2). If the control bit is LOW (target mode), an input HIGH-to-LOW transition at the TRIGGER I/O pin produces either an input or output trigger if either is enabled individually, or inputs and outputs simultaneously if both are enabled.

3.4.5 Input Data Buffer

3.4.5.1 Organization

Analog input data accumulates in the input data FIFO buffer until extracted by the PCI bus. The buffer has a capacity of 256K total samples, and contains a 16-bit data field, a 1-bit tag field, and an END OF BURST status bit (Table 3.4-2). Analog input data is right-justified to the LSB, and occupies bit positions D00 through D15.

NOTE: The input buffer capacity of 256 K-Samples is distributed among all active input channels. The capacity in samples-per-channel is:

$$\text{Sample Capacity per Channel} = 256\text{K} / \text{Number of active channels.}$$

The channel tag identifies the first (lowest-numbered) active channel in each active channel-set. Reserved bits are always returned as zeros. The END OF BURST (EOB) status bit identifies the last data value in an input burst or function.

Table 3.4-2. Input Data Buffer

Offset: 0018h

Default: 00XX XXXXh

DATA BIT	DESIGNATION	DESCRIPTION
D00	DATA00	Data value least significant bit (LSB)
D01-D14	DATA01 - DATA14	Data value intermediate bits
D15	DATA15	Data value most significant bit (MSB)
D16	FIRST-CHANNEL TAG	Tag assigned to first (lowest-numbered) active channel.
D17	END OF BURST (EOB)	Identifies the last input value in a burst.
D18-D31	(Reserved)	Always zero.

In order for the input buffer to acquire input data, the ENABLE INPUT BUFFER control bit must be set HIGH in the BCR. The buffer can be cleared, or emptied, by writing a "one" to the CLEAR INPUT BUFFER control bit in the BCR. The CLEAR INPUT BUFFER bit clears automatically. An empty buffer returns an indeterminate value.

The INPUT BUFFER OVERFLOW status bit in the BCR is set HIGH if the buffer overflows, thereby indicating data loss. The INPUT BUFFER UNDERFLOW bit is set HIGH if the buffer underflows (underruns), indicating that indeterminate data was acquired from an empty buffer. Each status bit remains HIGH until cleared, either directly from the bus, by the CLEAR INPUT BUFFER control bit, or by a board reset.

3.4.5.2 Buffer Size and Threshold Registers

The Input Buffer Size control register listed in Table 3.1-1 contains the total number of data values present in the input buffer. The Input Buffer Threshold register (Table 3.4-3) specifies the buffer size value above which the INPUT BUFFER THRESHOLD FLAG is asserted HIGH. The threshold flag is duplicated in the BCR.

Table 3.4-3. Input Buffer Threshold Register

Offset: 002Ch

Default: 0003 FFFEh

BIT	MODE	DESIGNATION	DEF	DESCRIPTION
D00-D18	RW	INPUT BUFFER THRESHOLD	3 FFFEh	Specifies the number of values in the input buffer, above which the threshold flag is asserted HIGH.
D19	RO	INPUT BUFFER THRESHOLD FLAG ¹	0	HIGH when the number of values in the input buffer exceeds the specified buffer threshold.
D20-D31	RO	Reserved	0	---

1. Duplicated in the BCR.

3.5 Analog Input Buffer DMA Operation

DMA transfers from the analog input buffer are supported with the board operating as a bus master. Set Bit 02 in the PCI Command register HIGH to select the bus mastering mode. Refer to the PCI-9056 reference manual for a description of DMA configuration registers.

3.5.1 Block Mode

Table 3.5-1 illustrates a *typical* PCI register configuration that would control a non-chaining, non-incrementing **block-mode** DMA transfer in DMA Channel 00, in which a PCI interrupt is generated when the transfer has been completed. For most applications, the DMA Command Status Register would be initialized to 0000 0001h, and then changed to 0000 0003h to initiate a transfer.

Table 3.5-1. Typical Input DMA Register Configuration; Block Mode

PCI Offset	PCI Register	Function	Typical Value
80h	DMA Mode	Bus width (32); Interrupt on done	0002 0D43h
84h	DMA PCI Address	Initial PCI data source address	*
88h	DMA Local Address	Initial (constant) local address	0000 0018h
8Ch	DMA Transfer Byte Count	Number of bytes in transfer	*
90h	DMA Descriptor Counter	Transfer direction (Local bus to PCI bus)	0000 0008h
A8h (D7:0)	DMA Command/Status	Command and Status Register	01h, 03h (See Text)

* Determined by specific transfer requirements.

3.5.2 Demand Mode (Firmware Revision 0006 and higher)

Demand mode transfers are controlled in a manner similar to block mode transfers, with the addition of **demand-mode** operation selected in the DMA mode register (D[12] = HIGH). Demand mode operation also requires the **slow terminate** mode (D[15] = LOW), which is the default state for this control bit. Table 3.5-2 shows a *typical* PCI register configuration for DMA Channel 00 demand mode operation.

Table 3.5-2. Typical Input DMA Register Configuration; Demand Mode

PCI Offset	PCI Register	Function	Typical Value
80h	DMA Mode	Bus width (32)	0002 1943h
84h	DMA PCI Address	Initial PCI data source address	*
88h	DMA Local Address	Initial (constant) local address	0000 0018h
90h	DMA Descriptor Counter	Transfer direction (Local bus to PCI bus)	0000 0008h
A8h (D7:0)	DMA Command/Status	Command and Status Register	01h, 03h (See Text)

* Determined by specific transfer requirements.

NOTE: The PCI-9056 adapter extracts data from the 32-Bit (Lword) local bus in 64-Bit (quad-word) increments. Consequently, *if the buffer runs empty or nearly empty*, the situation can arise in which the last one or two samples in an active channel group are retained until subsequent data is acquired. If this occurs, the next sample set flushes the retained data through the PCI-9056 adapter to the PCI bus, and no samples are lost.

NOTE: The default analog input DMA channel for demand-mode operation is Channel 00. To operate in DMA Channel 01, set the SWAP DEMAND MODE CHANNELS control bit HIGH in the BCR and use the Channel 01 PCI registers.

3.6 Data Coding Formats

Analog input and output data is arranged as 16 active right-justified data bits with the coding conventions shown in Figure 3.6-1. The default format is offset binary. Two's complement format is selected by clearing the OFFSET BINARY control bit LOW in the BCR. Unless indicated otherwise, offset binary coding is assumed throughout this document.

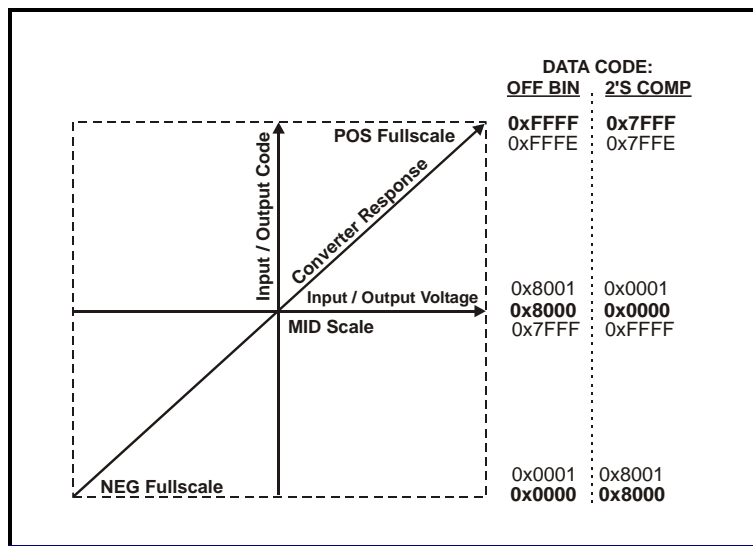

Figure 3.6-1. Analog Data Coding Formats; 16 Bit Data

3.7 Rate-A/B Generators

Two rate generators supply independent clock frequencies for ADC clocking and burst control. The Rate-A Generator shown in Table 3.7-1 generates an internal sample clock for the analog inputs. The Rate-B generator output can be used as a trigger source for input burst acquisition.

Each generator is enabled by the associated ENABLE RATE-A/B GENERATOR control bit in the BCR. The generators are disabled when these bits are LOW.

Table 3.7-1. Analog Input and Trigger Rate Generator Registers (Rate-A,B)

Offset: 001Ch (Rate-A), 0020h (Rate-B) Default: 0000 007E (Rate-A), 0000 2760h (Rate-B)

DATA BIT	MODE*	DESIGNATION	DEFAULT	DESCRIPTION
D00-D23	R/W	Ndiv	---	Rate generator frequency control
D24-D31	RO	(Inactive)	0	---

* R/W = Read/Write, RO = Read-Only.

The frequency **Fgen** (Table 3.7-2) of each generator is calculated as:

$$Fgen = Fclk / Ndiv,$$

where **Fclk** is the master clock frequency for the board, and **Ndiv** is the value written to the Rate-A/B Generator register. **Fgen** and **Fclk** are both expressed in the same frequency units. **Fclk** is assumed here to be 45.000 MHz, but custom frequencies are available. If the master clock is provided with a custom frequency, **Fclk** equals the custom frequency.

Table 3.7-2. Input Rate Generator Frequency Selection

Ndiv		FREQUENCY Fgen (45.000 MHz Master Clock)*
(Dec)	(Hex)	(kHz)
45	002D	1000
46	002E	978
---	---	Fgen (Hz) = Fclk (Hz) / Ndiv **

* ±0.003 percent.

** Fclk = master clock frequency; e.g.: 45.000MHz.

NOTE: Fgen should not exceed the maximum sample rate listed in the product specification. For input sampling rates above 800KSPS, the ANALOG INPUT WARP MODE control bit in the BCR should be set HIGH. In warp mode, the minimum sample rate is 1 KSPS, and the first sample acquired from all active channels after a lapse of 1 millisecond or longer should be discarded.

3.8 Multiboard Synchronization

Analog input and output clocking and triggering can be synchronized among multiple boards by designating one of the boards as an *initiator*, and the remaining boards as *targets*. In order to implement this function, the boards must be connected together as described in Paragraph 2.3.4.

When multiple boards are configured as an initiator and multiple targets, the analog input clock, the analog input trigger, and the analog output clock generated in the initiator board are duplicated in the target boards with delays of less than 100 nanoseconds.

All boards default to the target mode, with the ANALOG INPUT CLK INITIATOR and TRIGGER INITIATOR control bits cleared LOW in the BCR. To designate a board as a clock or trigger initiator, set the associated control bit HIGH.

NOTE: To avoid contention among boards that are wired in an initiator/target configuration, ensure that all target boards have been designated before initiating clocking operations.

3.9 Digital I/O Port

The bidirectional digital I/O port consists of six independently controlled data bits, as shown in Table 3.9-1. Each data bit DIO xx DATA is a hardware input if the corresponding direction control bit DIO xx OUTPUT SELECT is LOW, or is an output if the control bit is HIGH. Logic polarities are retained, with a HIGH level at a connector pin associated with a HIGH level for the corresponding bit in the Digital I/O Port register. All digital I/O lines default to inputs.

Table 3.9-1. Digital I/O Port Register

Offset: 0004h

Default: 0000 00XXh

DATA BIT	MODE*	DESIGNATION	DEFAULT	DESCRIPTION
D00	RW	DIO 00 DATA	X	Digital I/O Data; Bits 00-05
D01	RW	DIO 01 DATA	X	
D02	RW	DIO 02 DATA	X	
D03	RW	DIO 03 DATA	X	
D04	RW	DIO 04 DATA	X	
D05	RW	DIO 05 DATA	X	
D06-D07	RW	(Reserved)	0h	
D08	RW	DIO 00 OUTPUT SELECT	0	DIO direction control; High for output.
D09	RW	DIO 01 OUTPUT SELECT	0	
D10	RW	DIO 02 OUTPUT SELECT	0	
D11	RW	DIO 03 OUTPUT SELECT	0	
D12	RW	DIO 04 OUTPUT SELECT	0	
D13	RW	DIO 05 OUTPUT SELECT	0	
D14-D31	RO	(Reserved)	0h	

3.10 Autocalibration

To obtain maximum measurement accuracy, autocalibration should be performed after:

- Power warmup,
- PCI bus reset,
- Analog input or output range change.

The analog inputs are always calibrated on all input ranges during autocal, but to prevent damage to possibly low-voltage loads, the analog outputs are calibrated only on the selected output range.

Note: Analog outputs are active during autocalibration, and vary between +fullscale and midscale (zero) during the calibration sequence.

Autocalibration is invoked by setting the AUTOCAL control bit HIGH in the BCR. The control bit returns LOW automatically at the end of autocalibration. Autocalibration can be invoked at any time, and has a duration of less than 10 seconds. Completion of the operation can be detected either by monitoring the "Autocal Busy" status flag in the primary status register (Table 3.11-1), or by simply waiting a sufficient amount of time to ensure that autocalibration has been completed.

To compensate for component aging and to minimize the effects of temperature on accuracy, the autocalibration function determines the optimum calibration values for current conditions, and stores the necessary correction values in internal volatile memory. If a board is defective, the autocalibration process may be unable to successfully calibrate the inputs. If this situation occurs, the AUTOCAL PASS status bit in the BCR is cleared LOW at the end of the autocalibration interval, and remains LOW until a subsequent initialization or autocalibration occurs. AUTOCAL PASS is initialized HIGH, and remains HIGH unless an autocalibration failure occurs.

3.11 Primary Status Register

Critical status flags are consolidated into a single Primary Status register (Table 3.11-1), which is organized into a selection field and a response field. A response status bit is asserted if the selected event occurs after it has been selected. The response bit remains high until it is cleared from the PCI bus, either by clearing the response bit, *or by clearing the associated selection bit.*

NOTE: Response status bits can *only* be cleared LOW from the PCI bus. A "one" written to a response bit is ignored.

A selected event is edge-detected on a transition of the event from false to true. Once asserted, a response bit remains in that state until cleared from the bus, regardless of subsequent changes in the associated event state.

Table 3.11-1 Primary Status Register

Offset 0x0030		Default 0x0000 0000	
SELECTION BIT ¹	CRITICAL EVENT	RESPONSE BIT ²	REFERENCE PARAGRAPH
D00	Autocal completed	D16	3.10
D01	Input Buffer threshold flag HIGH-to-LOW transition	D17	3.4.5.2
D02	Input Buffer threshold flag LOW-to-HIGH transition	D18	
D03	Input Buffer Overflow or Underflow	D19	3.4.5.1
D04	Analog Input Burst initiated (BURST BUSY LO-HI)	D20	3.4.4.2
D05	Analog Input Burst Completed (BURST BUSY HI-LO)	D21	
D06	Analog Input Clock	D22	3.4.4
D07	Analog Output Clock	D23	3.13.4
D08	Digital I/O Port DIO 00 LOW-to-HIGH transition	D24	3.9
D09	Output Buffer threshold flag HIGH-to-LOW transition	D25	3.13.2.3
D10	Output Buffer threshold flag LOW-to-HIGH transition	D26	
D11	Output Load-Ready Flag HIGH-to-LOW transition	D27	3.13.3.3
D12	Output Load-Ready Flag LOW-to-HIGH transition	D28	
D13	Analog Output Burst Ready	D29	3.13.5.2
D14	Output Buffer Overflow or Frame Overflow	D30	3.13.2.3 3.13.3.3
D15	(Reserved)	D31	---

1. Event selection. Enables assertion of the corresponding response bit when the selected event occurs.

2. Event response. Asserted HIGH when a selected event occurs. Remains HIGH until cleared LOW.

3.12 Registered Analog Outputs

If the ENABLE BUFFERED OUTPUTS control bit is LOW in the BCR, the analog outputs are controlled in Direct-Register mode through the two ANALOG OUTPUT CHAN xx registers listed in Table 3.1-1. If the control bit is HIGH, then the outputs are controlled in the Buffered Outputs mode through the output buffer described in Section 3.13.

Each analog output channel is controlled directly through the associated ANALOG OUTPUT CHAN xx register. The outputs are double-buffered, and can be clocked either independently or simultaneously. Output data is written to a 16-bit field that is right-justified in the data registers (Table 3.12-1).

Table 3.12-1. Analog Output Channel Data Register

Offset: 0008h - 0014h

Default: 0000 8000h

DATA BIT	DESIGNATION	DESCRIPTION
D00	DATA00	Data value least significant data bit
D01-D14	DATA01 - DATA14	Data value intermediate data bits
D15	DATA15	Data value most significant data bit
D16-D31	(Reserved)	Data in this field is ignored.

3.12.1 Output Ranges

An output voltage range of $\pm 10V$, $\pm 5V$ or $\pm 2.5V$ is assigned by the OUTPUT RANGE control field in the BCR. The default output range is $\pm 10V$.

3.12.2 Clocking Modes

3.12.2.1 Immediate

When the SIMULTANEOUS OUTPUTS control bit is LOW in the BCR, each analog output channel is updated immediately when the associated data register receives a new value.

3.12.2.2 Simultaneous

When the SIMULTANEOUS OUTPUTS control bit is HIGH in the BCR, all analog outputs retain their existing values until an output clock occurs. An output clock updates all output channels simultaneously with the most recent data received by the data registers.

When operating in the simultaneous output clocking mode, an output clock is generated by:

- ♦ The OUTPUT S/W CLOCK control bit in the BCR, or:
- ♦ The internal Rate-C generator, or:
- ♦ An external clock input from the I/O connector,

as shown in Table 3.12-2

Table 3.12-2 Simultaneous Output Clock Source Selection

Register	Control Bit	S/W Clock (BCR)	Rate-C Gen	External Input
BCR	SIMULTANEOUS OUTPUTS	HIGH	HIGH	HIGH
	ENABLE RATE-C GENERATOR	X	HIGH	X
BOR *	ANALOG OUTPUT CLK INITIATOR	X	HIGH	LOW

* Buffered Outputs Operations register (Table 3.13-2).

To select the output clock *Initiator* mode, set ANALOG OUTPUT CLK INITIATOR **HIGH** in the Buffered Outputs Operations control register. In this mode, the bidirectional OUTPUT CLK I/O pin in the system I/O connector is an output, and each output clock produces a 100 nanosecond LOW output pulse.

If ANALOG OUTPUT CLK INITIATOR is **LOW**, designating the board as an output clock *Target*, the OUTPUT CLK I/O pin becomes an input, and an output clock is generated for each HIGH-to-LOW transition received at the pin. The Rate-C generator is ignored in the target clocking mode.

3.13 Buffered Analog Output Control

If the ENABLE BUFFERED OUTPUTS control bit is set HIGH in the BCR, the analog outputs are controlled through the output buffer in the *Buffered Outputs* mode described in this section (3.13).

This section describes those operations that control the movement of data from the PCI bus through the analog output buffer. These functions include the selection of active channels, the organization of data within the buffer, and the clocking of data from the buffer to the analog outputs. The principal parameters associated with controlling the analog output channels are summarized below in Table 3.13-1.

Table 3.13-1. Summary of Buffered Output Control Parameters

Parameter	Mode	Description
Data Control	Active Channels; Channel Group	A single set of all active output channels constitutes an Active Channel Group . Active channels are selected under a channel mask.
	Data Frame	All data values in the buffer comprise a <i>Data Frame</i> .
	Data Coding	Output data can be coded either in offset-binary format or in two's complement format.
Buffer Configuration	Open	Data read from the buffer is used and then discarded, until the buffer is empty.
	Circular (closed)	Data within the buffer is recirculated. Each value read from the output of the buffer FIFO is written back to the input of the FIFO. An end-of-frame (EOF) flag tracks the movement of data through the buffer.
Clock Source	External	External hardware provides the sample clock.
	Internal	The sample clock is provided by an internal rate generator, at a rate determined by the sample rate control register.
Clocking Mode	Simultaneous	At each clock occurrence, the next channel group (i.e.: a single group of all active channel values) in the output buffer is transferred to the respective analog output channels. All outputs are updated simultaneously.
	Sequential	At each clock occurrence, the next active channel value in the output buffer is transferred to the associated analog output channel, which is updated immediately.
Sampling Mode	Continuous	The contents of the output buffer are sampled continuously at the selected clock rate.
	Triggered Burst	A single data frame in the buffer is clocked to the outputs.

3.13.1 Data Organization

3.13.1.1 Active Channels

Analog output data is loaded into the output buffer in discrete groups or frames of channel data. An *active channel group* consists of a single set of output values for all active channels.

Only active output channels receive data from the output buffer. A channel that is deselected to the inactive state retains the last value that was received while the channel was still active. During initialization, all channels are designated as active and are set to midrange (zero output level).

3.13.1.1.1 Selection

An output channel is selected as *active* by setting the corresponding AO CHANNEL-xx-ACTIVE selection bit HIGH in the Buffered Output Operations register shown in Table 3.13-2. A channel is deselected to the *inactive* state by clearing the corresponding selection bit.

3.13.1.1.2 Loading

Channel data values are loaded into the output buffer in ascending order of active channels. The channel groups are loaded contiguously, beginning with the first group to be transferred to the outputs, and proceeding sequentially to the last group. Figure 3.13-1 illustrates a loading example that implements both output channels, with 100 values per channel. Each channel group consists of active channels 0 and 1.

NOTE: Data can be loaded from the PCI bus to the output buffer only if the buffer is open; that is, not circular or closed (3.13.2.4).

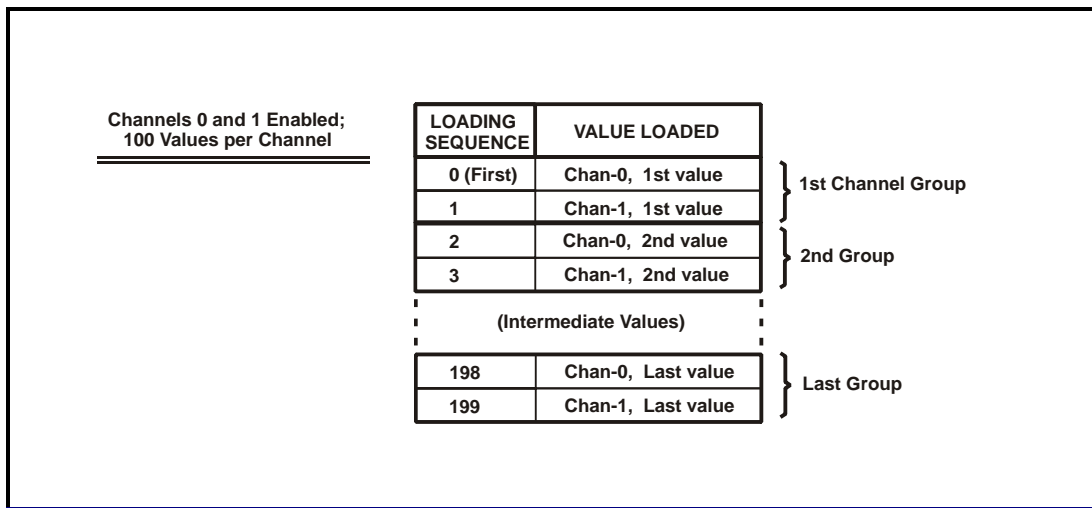

Figure 3.13-1. Typical Buffer Loading Sequence

Table 3.13-2. Buffered Output Operations Register

Offset: 003Ch

Default: 0000_1043h

BIT	MODE	DESIGNATION	DEF	DESCRIPTION	REF
D00	R/W	AO CHAN 00 ACTIVE	1	Active-channel mask for analog output channels. HIGH => Active; LOW => Inactive.	3.4.1.1
D01	R/W	AO CHAN 01 ACTIVE	1		
D02-D03	R/W	(Reserved)	0h		
D04	R/W	ANALOG OUTPUT CLK INITIATOR	0	Selects the internal Rate-C generator for output clocking if HIGH, or the Output Clock I/O hardware input if LOW.	3.13.4.1
D05	R/W	ENABLE OUTPUT CLOCKING	0	Enables output clocking when HIGH. Disables clocking when LOW. Default is LOW (clocking disabled).	3.13.4
D06	RO	OUTPUT CLOCK READY	1	Indicates when HIGH that an output clock will be accepted. If LOW, indicates that the output will not respond to a clock.	3.13.4
D07	R/W	OUTPUT SW CLOCK *	0	Produces a single output clock event when asserted. Independent of clocking mode. Duplicated in the BCR.	3.13.4.1
D08	R/W	CIRCULAR BUFFER	0	Selects circular buffer configuration if HIGH, or open self-flushing buffer configuration if LOW. Access for loading new data into the circular buffer must be requested by asserting LOAD REQUEST. Default is LOW; i.e. open buffer.	3.13.2.5
D09	R/W	LOAD REQUEST *	0	When set HIGH, requests loading access to the circular buffer. Initializes LOW.	3.13.3.3
D10	RO	LOAD READY	0	Set HIGH when the frame index passes through zero, if both CIRCULAR BUFFER and LOAD REQUEST are HIGH. When HIGH, indicates that the circular buffer is ready to accept new data. Available also in the PSR. Defaults HIGH.	3.13.3.3
D11	R/W	CLEAR OUTPUT BUFFER *	0	Resets the output buffer to empty.	3.13.2.3
D12	RO	AO BUFFER EMPTY	1	Indicates the analog output buffer is empty.	3.13.2.3
D13	RO	OUTPUT BUFFER THRESHOLD	0	Analog output buffer threshold flag. Duplicated in the AO Buffer Threshold register.	3.13.2.3
D14	RO	(Reserved)	0	Inactive; Returns zero.	---
D15	RO	AO BUFFER FULL	0	Indicates the output buffer is full.	3.13.2.3
D16	R/W	AO BUFFER OVERFLOW	0	Set HIGH when data is written to a full buffer. **	3.13.2.3
D17	R/W	FRAME OVERFLOW	0	Set HIGH when data is written to a closed buffer. **	3.13.2.3
D18	RO	BURST READY	0	If HIGH, indicates that a burst trigger will be accepted. If LOW, indicates that the output will not respond to a trigger.	3.13.5
D19	R/W	ENABLE OUTPUT BURST	0	Enables analog output burst operation.	3.13.5.2
D20	R/W	OUTPUT SW TRIGGER *	0	Produces a single output trigger event when asserted. Clears LOW automatically when the clock event is completed. Independent of triggering mode. Duplicated in the BCR.	3.13.5.2
D21	R/W	SWAP DEMAND MODE CHANNELS	0	Reverses the default demand-mode DMA channels for analog inputs and outputs	3.5 3.15
D22-D31	RO	(Reserved)	0	Inactive. Returns all-zero.	---

* Clears LOW automatically when operation is completed.

** Remains HIGH until cleared by a direct write as LOW, or by initialization.

3.13.1.2 Data Frame

A *data frame* consists of an integral number of channel groups.

For triggered bursts, or for function concatenation, the last active channel in the last channel group is designated as the *end-of-frame* (EOF). The EOF designation is applied by setting the EOF flag (D16) HIGH when loading the last channel value into the buffer. Thereafter, the EOF flag follows the last channel value through the buffer.

3.13.1.3 Voltage Range Selection

An output voltage range of $\pm 10V$, $\pm 5V$ or $\pm 2.5V$ is assigned by the OUTPUT RANGE control field in the BCR. The default output range is $\pm 10V$.

For maximum accuracy, autocalibration should be performed after a new output range is selected.

3.13.2 Output Buffer

Analog output data from the PCI bus is first corrected for offset and gain errors, and then flows directly into the 256K-sample analog output FIFO data buffer. From the buffer, the corrected data is routed to the analog output DAC channels.

NOTE: The output buffer capacity of 256 K-Samples is distributed among all active output channels. The capacity in samples-per-channel is:

$$\text{Sample Capacity per Channel} = 256K / \text{Number of active channels.}$$

3.13.2.1 Output Data Format

Analog output data values are written in Lword-serial sequence from the PCI bus to the Analog Output Buffer register shown in Table 3.13-3. Bits D15..0 represent the output data value. Bit D16 is set HIGH to indicate the last value in a data frame, and is the end-of-frame (EOF) flag. Bits D31..17 are inactive. Access to the output buffer is supported for both single-longword transfers and single-address multiple-longword DMA transfers. The output buffer appears to the PCI bus as a single register, and a read-access to this register returns an all-zero value.

Table 3.13-3. Analog Output Buffer

Offset: 0048h		Default: N/A (Write-Only)	
BIT	MODE*	DESIGNATION	DESCRIPTION
D00	WO	DATA 00	Least significant data bit
D01-D14	WO	DATA 01 - DATA 14	Intermediate data bits
D15	WO	DATA 15	Most significant data bit
D16	WO	EOF FLAG	End-of-frame (EOF) flag.
D17-D31	WO	---	(Inactive)

* WO indicates write-only access. Read-access returns all-zero value.

3.13.2.2 Output Data Coding

Analog output data coding is described in Paragraph 3.6.

3.13.2.3 Output Buffer Control

The Buffered Output Operations register in Table 3.13-2 controls and monitors the flow of data through the analog output data buffer. Asserting the CLEAR OUTPUT BUFFER control bit HIGH clears, or empties, the buffer.

The AO BUFFER OVERFLOW flag is set HIGH if data is written to a full buffer, and the FRAME OVERFLOW flag indicates that an attempt was made to write data to a closed buffer. Both flags indicate data loss. Each of these flags, once set, remains HIGH until written LOW directly from the bus, or by initialization .

The AO BUFFER EMPTY flag indicates that the buffer contains no output data. The AO BUFFER FULL flag is asserted when the buffer is full. Data written to a full output buffer is discarded.

The Buffer Size register shown in Table 3.13-4 contains the number of output data values present in the buffer, and is updated continuously.

Table 3.13-4. Output Buffer Size Register

Offset: 0044h

Default: 0000 0000h

DATA BIT	MODE*	DESIGNATION	DEF	DESCRIPTION
D00-D18	RO	BUFFER SIZE	0 0000h	Number of values in the output buffer
D19-D31	RO	(Inactive)	0	---

The Output Buffer Threshold register in Table 3.13-5 specifies the buffer size value above which the OUTPUT BUFFER THRESHOLD FLAG is asserted HIGH. This status flag is duplicated in the Buffered Output Operations register.

Table 3.13-5. Output Buffer Threshold Register

Offset: 0040h

Default: 0003 FFFEh

BIT	MODE	DESIGNATION	DEF	DESCRIPTION
D00-D18	RW	OUTPUT BUFFER THRESHOLD	3 FFFEh	Specifies the number of values in the output buffer, above which the threshold flag is asserted HIGH.
D19	RO	OUTPUT BUFFER THRESHOLD FLAG	0	HIGH when the number of values in the output buffer exceeds the specified buffer threshold.
D20-D31	RO	Reserved	0	---

3.13.2.4 Open Buffer

If the CIRCULAR BUFFER control bit is LOW in the buffer operations register (Table 3.13-2), the output buffer operates in the open mode. Data in an open buffer is discarded as it is used. Consequently, the buffer is self-flushing, and will empty itself unless it is replenished from the PCI bus. This mode of operation permits the continuous flow of data from the PCI bus to the analog outputs.

The open-buffer configuration also can be used to produce a one-shot waveform, provided the particular waveform is to be used only once. Figure 3.13-2 illustrates the movement of a single data frame through an open buffer.

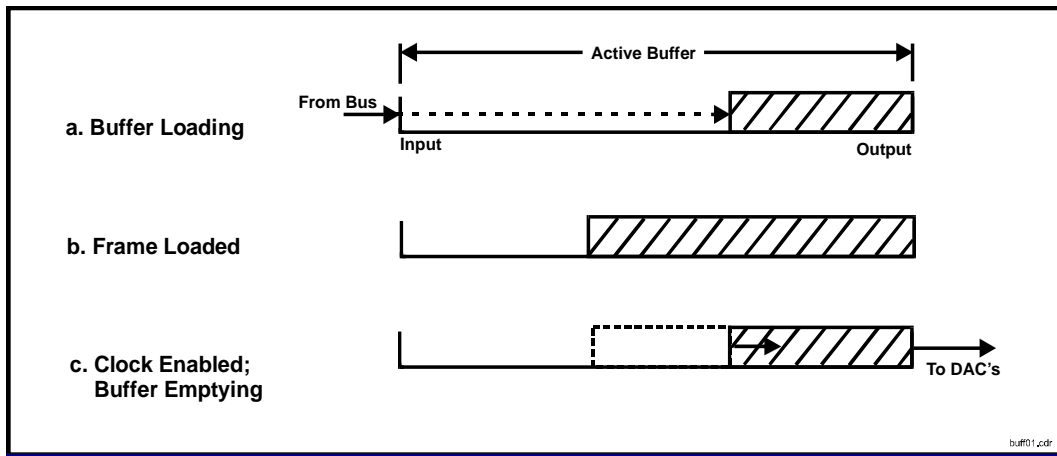

Figure 3.13-2. Open Buffer Data Flow

3.13.2.5 Circular Buffer

Data in a circular (closed) buffer is retained indefinitely. This configuration generally is implemented to produce either periodic waveforms of constant frequency, or one-shot transient waveforms that will be used repeatedly but not necessarily periodically. While closed, the buffer is not accessible from the PCI bus.

In Figure 3.13-3 a single data frame is loaded into the buffer. The buffer is then closed (CIRCULAR BUFFER set HIGH) and clocking is enabled. The data frame subsequently circulates in the buffer while passing data values to the output channels.

An end-of-frame (EOF) flag accompanies the end-point, or last value in a data frame. The EOF flag is D16 in the buffer, and is set HIGH when the last value in a data frame is loaded. This flag is used at the end of a function or triggered burst to define the last value. Multiple contiguous burst functions, or frames, can reside in the buffer simultaneously.

NOTE: Disable output clocking before loading the output buffer for circular operation.

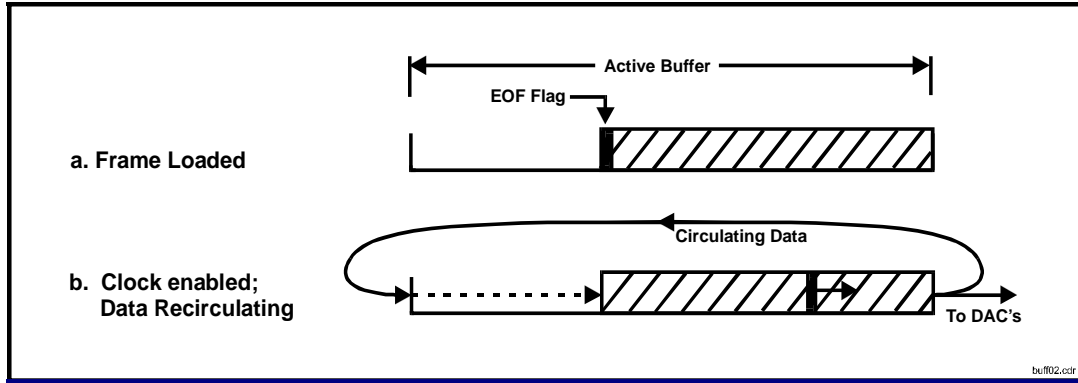

Figure 3.13-3. Circular Buffer Data Flow

3.13.3 Function Generation

3.13.3.1 Periodic and One-Shot Functions

Periodic waveforms are produced when the buffer is configured for continuous sampling and circular operation. In this mode, the contents of the buffer are scanned continuously as long as clocking is enabled and a clock is present. The data frame is recirculated through the buffer repeatedly. Clocking is enabled when the ENABLE OUTPUT CLOCKING control bit in the buffer operations register is HIGH.

If triggered-burst sampling is used in conjunction with a circular buffer, a *one-shot waveform* is produced that contains all values within a single data frame. The triggered burst is initiated by a software or hardware trigger, and terminates automatically when the end-of-frame (EOF) flag is encountered. Because the buffer is circular, the waveform is retained in the buffer and can be reproduced repeatedly by subsequent triggers.

3.13.3.2 Multiple Functions

When multiple functions are loaded into the buffer as contiguous data frames, and if triggered-burst sampling is selected, the functions will be generated sequentially in response to a series of burst triggers. If the buffer is open, the functions are flushed from the buffer as they are clocked to the analog outputs. However, if the buffer is closed (circular), the functions are retained in the buffer, and the series of functions is repeated indefinitely. .

3.13.3.3 Function Sequencing (Concatenation)

A new function can be concatenated to the end of an existing function in a circular buffer, while the existing function is being flushed from the buffer. During this operation, the existing function is flushed from the buffer as it is clocked to the outputs, and is replaced by the new function. When the last value of the existing function is clocked out of the buffer, the buffer closes and the new function seamlessly begins circulating in the buffer and producing an output.

Introduction of a new function commences by setting the LOAD REQUEST flag HIGH in the buffered output operations register (Table 3.13-2), and by then waiting for the LOAD READY flag to be asserted. (In effect, LOAD REQUEST is an "interrupt request" to the buffer). The LOAD READY flag indicates that the buffer has opened, and that the existing function is being flushed from the buffer, beginning with the first value in the function's data frame.

After LOAD READY goes HIGH, the new function is written to the buffer and is terminated with an EOF flag (output data bit D16 set HIGH). The EOF flag of the existing function causes the buffer to close, and clears both the LOAD READY flag and the LOAD REQUEST control bit. Notice that the loading of the new function into the buffer must be completed before the existing function terminates.

In Figure 3.13-4, an existing function is replaced by a new function while the existing ('old') function is flushed from the buffer.

NOTE: If the loading of a new function extends beyond the LOAD-READY interval, the FRAME OVERFLOW flag is set HIGH in the Buffer Operations register, indicating data loss. Once set, this flag remains HIGH until written LOW directly from the bus, or by initialization

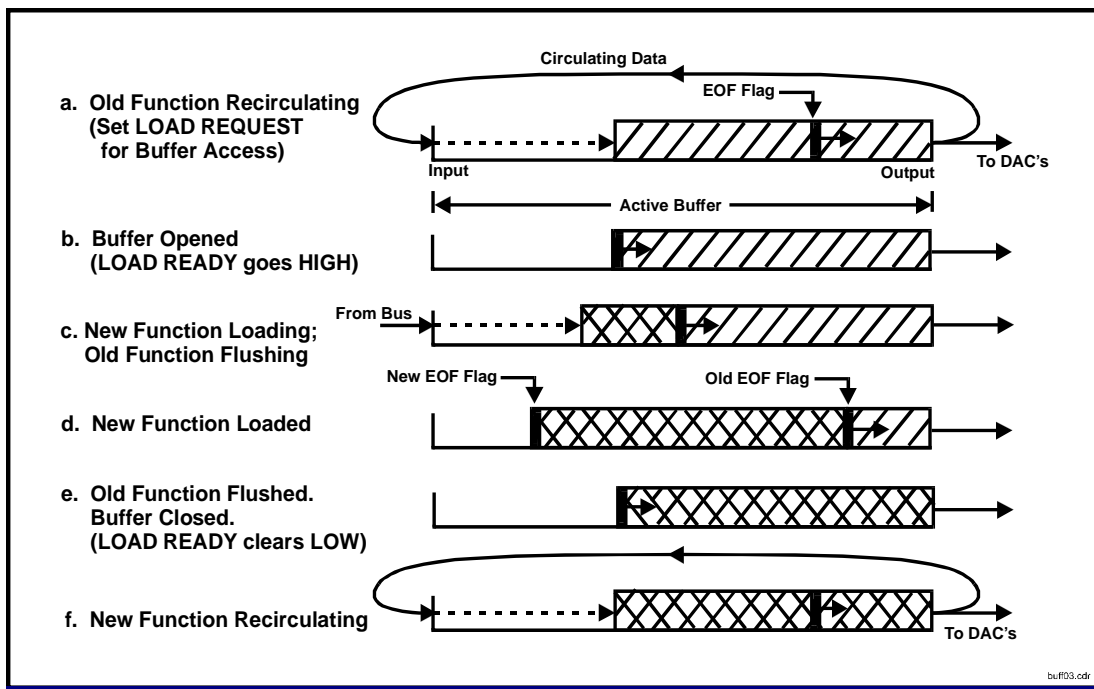

Figure 3.13-4. Function Sequencing

3.13.4 Output Clocking

If the ENABLE OUTPUT CLOCKING control bit in the buffer operations register is asserted HIGH, clocking is enabled and the active analog outputs are updated at each occurrence of the sample clock. The sample clock can be generated internally by the rate generator, or can be supplied externally through the I/O connector. Output clocking is disabled when the ENABLE OUTPUT CLOCKING control bit is LOW. The OUTPUT CLOCK READY flag indicates that data is available to be clocked to the output channels .

Hardware output signal OUTPUT CLK I/O (Table 2.2-1) goes LOW momentarily each time a sample clock occurs, Connecting this signal to the OUTPUT CLK I/O pins of other boards permits synchronous clocking of multiple boards.

3.13.4.1 Clock Source

When buffer operations register bit ANALOG OUTPUT CLK INITIATOR is LOW, the output clock is supplied externally through the I/O connector as OUTPUT CLK I/O. If the control bit is HIGH, the output clock is derived from the internal Rate-A generator. An output clock can also be supplied at any time by asserting the OUTPUT SW CLOCK control bit, which clears automatically. This control bit is duplicated in the BCR.

3.13.4.1.1 External Clock

The external clock source can have any frequency up to the maximum value specified for the output sampling rate. When the external clock source is selected, sampling occurs on a HIGH-to-LOW transition of the OUTPUT CLK I/O pin in the I/O connector.

3.13.4.1.2 Internal Output Rate Generator

The internal Rate-C generator provides a sample clock that is adjustable by the RATE[23..0] control bits in the Output Sample Rate control register shown in Table 3.13-6. The Rate-C generator is enabled by setting the ENABLE RATE-C GENERATOR control bit HIGH in the BCR.

Table 3.13-6. Output Sample Rate Control Register (Rate-C)

Offset: 004Ch

Default: 0000_007Eh

DATA BIT	MODE	DESIGNATION	DESCRIPTION
D00	R/W	RATE 00	Least significant rate bit
D01-D22	R/W	RATE 01 - RATE 22	Intermediate rate bits
D23	R/W	RATE 23	Most significant rate bit
D24-D31	RO	---	Inactive. Returns all-zero.

The output clocking rate **Fclock** is calculated from the relationship:

$$\mathbf{Fclock\ (Hz)\ =\ Fclk\ /\ Nrate\ ,}$$

where **Nrate** is the decimal equivalent of the value in the RATE value in the Sample Rate control register, and **Fclk** is the master clock frequency for the board. **Fclk** is assumed here to be 45MHz, but custom frequencies are available. Table 3.13-7 illustrates the effect of **Nrate** on the sample rate. Clocking rates significantly above **1000 KSPS** can produce unpredictable results and are not recommended. **Nrate** should not be modified during function generation.

Table 3.13-7. Output Sample Rate Selection

Ndiv		FREQUENCY Fgen (45.000 MHz Master Clock)*
(Dec)	(Hex)	(kHz)
45	002D	1000
46	002E	978
---	---	Fclock (Hz) = Fclk (Hz) / Ndiv **

* ±0.003 percent.

** Fclock = master clock frequency; e.g.: 45.000MHz.

3.13.4.2 Simultaneous Clocking

Simultaneous sampling is selected by setting the SIMULTANEOUS OUTPUTS control bit in the board control register HIGH. If simultaneous sampling is selected, the analog values in each successive channel group appear simultaneously at the outputs, with minimum time-skew between channels. Upon each occurrence of the sampling clock, an entire active channel group is transferred from the output buffer, and all outputs are updated simultaneously. In this mode, the effective sample rate for each channel equals the output clocking rate **Fclock**.

3.13.4.3 Sequential Operation

Sequential sampling is selected when the SIMULTANEOUS OUTPUTS control bit in the board control register is LOW. At each clock occurrence in sequential operation, a single channel value is transferred from the buffer to the associated output channel, and the channel is updated immediately. Channel values are read from the buffer beginning with the lowest-numbered active channel in a channel group, and proceeding upward through the highest-numbered active channel. When operating in this mode, the effective sample rate for each channel equals the output clocking rate **Fclock** divided by the number of active channels.

3.13.5 Sampling Mode

3.13.5.1 Continuous Sampling

If the ENABLE OUTPUT BURST control bit in the Buffered Output Operations register is LOW (default), the *continuous sampling* mode is selected and data is transferred continuously from the buffer to the analog outputs, assuming that the buffer is not empty and that an output clock is present.

3.13.5.2 Data Bursts

If the ENABLE OUTPUT BURST control bit in the Buffered Output Operations register is HIGH, burst operation is selected. During a *triggered output burst*, data is transferred continuously from the output buffer to the analog outputs until either the **buffer goes empty, or the end-of-frame (EOF) flag is encountered**. In the triggered-burst sampling mode, an internal or external output trigger initiates the transfer of data from the output buffer to the output channels.

If the TRIGGER INITIATOR control bit in the BCR is HIGH, *internal triggering* is selected, and either a software or hardware trigger will initiate a burst. A software trigger is generated by setting the OUTPUT S/W TRIGGER control bit HIGH (duplicated in the BCR), and a hardware trigger is provided by the Rate-B generator, if enabled. These trigger sources are independent of each other, and the occurrence of either or both will initiate a burst. The OUTPUT SW TRIGGER bit remains HIGH during the burst, and clears automatically when the burst is completed.

In the initiator mode, hardware output pin TRIGGER I/O produces a LOW pulse at the beginning of each burst. Connecting this signal to the TRIGGER I/O pins of other boards permits synchronous burst triggering of multiple boards.

If the TRIGGER INITIATOR control bit is LOW in the BCR, indicating *Target Mode or External triggering*, a hardware burst trigger occurs upon a HIGH-to-LOW transition of the TRIGGER I/O pin in the I/O connector, *if* the ENABLE OUTPUT BURST control bit in the operations register is HIGH, *and* if the BURST READY flag also is HIGH. The BURST READY flag is LOW during a burst, and is HIGH if no burst is in progress. The OUTPUT S/W TRIGGER control bit also is active in the target mode.

Multiple burst functions can exist simultaneously within the buffer if the end-of-frame (EOF) flag is used (3.13.2.1). The EOF flag defines the last output value in each data burst. After a burst is triggered, data values from the buffer are clocked to the analog outputs at the selected sample rate until the EOF flag is encountered. The burst then terminates, and clocking of the buffer ceases until a subsequent trigger occurs.

Refer also to the Trigger Initiator note in 3.4.4.2.

3.13.6 Multiboard Synchronization

Boards that are configured for *synchronous clocking* update their outputs simultaneously in response to a common *clock* signal. Boards that are configured for *synchronous burst triggering* initiate data bursts simultaneously in response to a common *trigger* signal. Multiple boards can be arranged to operate with:

- a. Independent clocking and burst triggering
- b. Synchronous burst triggering (Common burst trigger)
- c. Synchronous clocking (Common DAC clock)
- d. Synchronous clocking and burst triggering (Common trigger and DAC clock).

As many as four boards can be synchronized together. External clock and trigger I/O signaling uses standard TTL levels.

3.13.6.1 Synchronous Bursts

To ***burst-synchronize*** a group of boards, the TRIGGER I/O signal from one board, the *burst-initiator*, is connected to the TRIGGER I/O pins of a group of *burst-target* boards. Each burst-target, when operated in the triggered-burst mode, initiates a single burst from its buffer each time the burst-initiator initiates a burst.

3.13.6.2 Synchronous Clocking

To ***clock-synchronize*** multiple boards together, the OUTPUT CLK I/O from one board, designated the *clock-initiator*, is connected to the OUTPUT CLK I/O pin of one or *more clock-target* boards. In this case, the clock-targets are configured for external clocking (ANALOG OUTPUT CLK INITIATOR cleared LOW in the operations control register), and the initiator is configured for internal clocking.

3.14 Buffered Analog Output Application Examples

NOTE: This section provides examples of operation in the Buffered Outputs mode, and assumes that the ENABLE BUFFERED OUTPUTS control bit is set HIGH in the BCR.

Specific operating modes and procedures vary widely according to the unique requirements of each application. The examples presented in this section (Table 3.14-1) illustrate several basic operating modes, and can be modified or combined for more complex operations.

References to *functions* in these examples generally apply to a single output channel for simplicity of explanation. However, each active channel represents an independent set of function values, and all channels share a common output clock.

Table 3.14-1. Summary of Operation Examples

Operation Example	Description
Sequential Direct Outputs	Each value written to the output data buffer updates the associated analog output channel when clocked, independently of the other channels.
Simultaneous Direct Outputs	Data values accumulate in the output data buffer until an entire channel group has been loaded. When the last channel is loaded, all active output channels update simultaneously when clocked.
Continuous Function	An extension of Simultaneous Direct Outputs, in which the buffer is not allowed to become either empty or full.
Periodic Function	A single function is generated repeatedly in each active channel.
Function Burst	One or more functions are generated as discrete data bursts. The burst cycle is repeated indefinitely if the circular-buffer mode is selected.
Function Sequencing	An existing active function is replaced seamlessly by a new function.

Each of the examples in this section assumes that the initial operations listed in Table 3.14-2 have already been performed.

Table 3.14-2. Initial Operations

Operation	Default Value	Applicable Paragraph
The board has been reset or initialized.	---	3.3.2
The active channel group has been defined .	All channels active	3.13.1.1
The required output coding has been selected.	Offset binary	3.6

The remaining operational parameters are assumed to be in the following *default* states initially:

Parameter	Default
Buffer mode:	Open
Buffer status:	Empty
Clock source:	External (Buffer Operations register)
Clock status:	Disabled (Buffer Operations register)

Parameter	Default
Sample rate:	320KSPS
Sampling mode:	Sequential

3.14.1 Sequential Direct Outputs

Table 3.14-3. Sequential Direct Outputs Example

Operation	PCI Bus Action	Board Response
Select Internal Clocking	Set the ANALOG OUTPUT CLK INITIATOR control bit HIGH in the buffer operations register.	The internal Rate-C generator is selected as the output clocking source.
Enable clocking	Set the ENABLE OUTPUT CLOCKING control bit HIGH in the buffer operations register. Set the ENABLE RATE-C GENERATOR control bit HIGH in the BCR.	Clocking is enabled at the default rate.
Load the output value for the first active channel.	Write the first value to the output data buffer.	Output value appears immediately (when clocked) at the analog output.
Load the output values for the remaining active channels.	Write the remaining active channel values to the output data buffer.	Remaining active analog outputs are updated in ascending sequence.
Repeat the above operations for subsequent channel groups.	Continue to write output values to the output data buffer.	Each value written to the buffer is transferred immediately to the associated analog output when clocked

- Notes:
1. End-of-frame (EOF) flags are ignored when operating in the open-buffer mode. Only D15..0 are active in the output buffer.
 2. Data written to the buffer at rates above 1000KSPS will accumulate in the buffer.
 3. Access to an individual output channel is accomplished by first selecting (enabling) only the specific channel, and by then writing the output value to the buffer.

3.14.2 Simultaneous Direct Outputs

Table 3.14-4. Simultaneous Direct (Single Group) Outputs Example

Operation	PCI Bus Action	Board Response
Select simultaneous clocking.	Set SIMULTANEOUS OUTPUTS in the BCR.	Simultaneous clocking is selected.
Select Internal Clocking	Set the ANALOG OUTPUT CLK INITIATOR control bit HIGH in the buffer operations register.	The internal Rate-C generator is selected as the output clocking source.
Enable clocking	Set the ENABLE OUTPUT CLOCKING control bit HIGH in the buffer operations register. Set the ENABLE RATE-C GENERATOR control bit HIGH in the BCR.	Clocking is enabled at the default rate.
Clear the output buffer.	Set the CLEAR OUT BUFFER bit in the output operations register.	The output buffer clears to empty.
Load the output value for the first active channel.	Write the first value to the output data buffer.	First value is retained in the buffer.
Load the output values for the remaining active channels.	Write the remaining active channel values to the output data buffer.	Remaining values are accumulated in the buffer. When the last value is loaded, all values are extracted from the buffer and appear simultaneously at the associated output channels.
Repeat the above operations for subsequent channel groups.	Continue to write output values to the output data buffer.	All active channels are updated simultaneously when the last value in each group is written to the buffer.

Notes: 1. Data written to the buffer at rates above 1000KSPS will accumulate in the buffer.

3.14.3 Continuous Function

Table 3.14-5. Continuous Function Example

Operation	PCI Bus Action	Board Response
Select simultaneous clocking.	Set SIMULTANEOUS OUTPUTS in the board control register.	Simultaneous clocking is selected.
Set the buffer threshold flag to 1/4 of the expected block size.	Write 1/4 block size to the threshold register (Table 3.13-5).	The threshold flag will go LOW when the buffer contents drop below the threshold.
If the internal rate generator is to be used, select the sample rate. (Skip this step if external clocking will be used).	Write the required sample clocking rate to the Rate-C generator control register.	The frequency of the internal rate generator is selected, if internal clocking is required.
If internal clocking is required, select internal clocking.	To select internal clocking, set the ANALOG OUTPUT CLK INITIATOR bit HIGH in the buffer operations register.	Internal clocking is selected, if required.
Enable clocking	Set the ENABLE OUTPUT CLOCKING control bit HIGH in the buffer operations register. Set the ENABLE RATE-C GENERATOR control bit HIGH in the BCR.	Clocking is enabled at the selected rate. The internal rate generator is enabled, if internal clocking is required.
Clear the output buffer.	Set the CLEAR OUT BUFFER bit in the output operations register.	The output buffer clears to empty.
Write a block of values to all active channels. To avoid discontinuities in the output functions, the effective loading rate for channel groups must be greater than the sample (clocking) rate times the number of active channels. Maximum loading rate is 40MSPS during DMA transfers.	Write function values for all active channels to the output data buffer.	All active channels produce their respective output functions.
Wait for the buffer threshold flag to go LOW. (See Note 1).	Monitor the analog output buffer threshold flag until LOW.	The output buffer empties to less than 1/4-full status.
Repeat the previous two steps to sustain function generation.		All output functions proceed continuously.

Notes:

1. Response to the flag must be fast enough to prevent the buffer from going empty.

3.14.4 Periodic Function

Table 3.14-6. Periodic Function Example

Operation	PCI Bus Action	Board Response
Select simultaneous clocking.	Set SIMULTANEOUS OUTPUTS in the board control register.	Simultaneous clocking is selected.
Clear the output buffer.	Set the CLEAR OUTPUT BUFFER bit in the output operations register.	The output buffer clears to empty.
Load the first function value for each active channel.	Write the values for the first active group to the output data buffer.	Initial values for all active channels accumulate in the buffer.
Load the remaining function values for all active channels. (Note 1) Set the end-of-frame (EOF) flag.	Write all remaining function values for all active channels to the output buffer. Set the EOF flag (D16 in the output buffer) HIGH when writing the data value for the last channel in the last group.	Remaining function values for all active channels accumulate in the buffer. The EOF flag is set HIGH in the buffer location that contains the last channel value in the last channel group.
If the internal rate generator is to be used, select the sample rate. (Skip this step if external clocking will be used).	Write the required sample clocking rate to the Rate-C generator control register.	The frequency of the internal rate generator is selected, if internal clocking is required.
Note: The remaining operations may be performed simultaneously with a single write-transaction to the buffer operations register:	---	---
Select the circular buffer mode.	Set CIRCULAR BUFFER in the buffer operations register.	The output buffer is closed (circular).
If the internal rate generator is to be used, select internal clocking.	To select internal clocking, set the ANALOG OUTPUT CLK INITIATOR bit HIGH in the buffer operations register.	The internal Rate-C generator is selected, if required.
Enable the sample clock.	Set ENABLE OUTPUT CLOCKING in the buffer operations register. Set the ENABLE RATE-C GENERATOR control bit HIGH in the BCR.	Clocking is enabled. All active channels produce their respective functions repeatedly until the clock is disabled or the operating mode is changed. All outputs update simultaneously at the sample clock rate.

Notes:

1. To generate periodic functions simultaneously in multiple channels, all functions must be commensurate. That is, the functions in all channels must have frequencies that are exact integer multiples of the frequency of the lowest-frequency channel. Conversely, the period of the lowest-frequency channel must be an exact integer multiple of the period of each of the other channels.

3.14.5 Function Burst

Table 3.14-7. Function Burst Example

Operation	PCI Bus Action	Board Response
Select simultaneous clocking.	Set SIMULTANEOUS OUTPUTS in the board control register.	Simultaneous clocking is selected.
Clear the output buffer.	Set the CLEAR OUT BUFFER bit in the output operations register.	The output buffer clears to empty.
Load the first function value for each active channel.	Write the values for the first active group to the output data buffer.	Initial values for all active channels accumulate in the buffer.
Load the remaining function values for all active channels. Set the end-of-frame (EOF) flag.	Write all remaining function values for all active channels to the output buffer. Set the EOF flag (D16 in the output buffer) HIGH when writing the data value for the last channel in the last group.	All function values for all active channels accumulate in the buffer. The EOF flag is set HIGH in the buffer location that contains the last channel value in the last channel group.
If more than one burst-function is required, repeat the previous operations for each additional function.	---	If required, additional burst functions accumulate in the output buffer.
Select the trigger source.	For internal triggering, set the TRIGGER INITIATOR bit HIGH in the BCR. For external triggering, clear the bit LOW (default).	The frequency of the internal rate generator is selected, if internal clocking is required.
If the internal rate generator is to be used for clocking , select the clocking rate.	Write the required clocking rate to the Rate-C generator control register.	The frequency of the internal rate generator is selected, if internal clocking is required.
If the internal rate generator is to be used for triggering , select the triggering rate.	Write the required triggering rate to the Rate-B generator control register.	The frequency of the internal rate generator is selected, if internal triggering is required.
Select triggered-burst mode.	Set ENABLE OUTPUT BURST in the buffer operations register.	The triggered-burst operating mode is selected.
Prepare the buffer operations register for burst mode:	Write to the buffer operations register:	---
If the burst functions will be used repeatedly, select the circular buffer mode.	To select the circular buffer mode, set CIRCULAR BUFFER.	If required, the output buffer is closed (circular), and all functions will be retained in the buffer indefinitely.
If internal clocking is required, select internal clocking.	To select internal clocking, set ANALOG OUTPUT CLK INITIATOR.	Internal clocking is selected, if required.
Enable the sample clock.	Set ENABLE OUTPUT CLOCKING.	Output clocking is enabled.
Enable the internal rate generators, if required.	Set the ENABLE RATE-B and RATE-C GENERATOR control bits in the BCR.	Required internal rate generators are enabled.

3.14.5 Function Burst (Continued)

Table 3.14-7. Function Burst Example (Continued)

Operation	PCI Bus Action	Board Response
For software burst triggering, generate a software trigger to produce a single burst on all active output channels.	Set OUTPUT SW TRIGGER in the buffer operations register..	All active output channels produce a single burst in response to each software trigger, if software triggering is used.
For external burst triggering, or internal rate-generator triggering, no further bus activity is required.	---	All active output channels produce a single burst in response to each internal or external trigger.

3.14.6 Function Sequencing (Concatenation)

Table 3.14-8. Function Sequencing Example

Operation	PCI Bus Action	Board Response
<p>Establish a periodic function as described in Paragraph 3.14.4. The following operations will replace the original ('old') function in each channel with a new function.</p>	<p>---</p>	<p>Each active output is producing a specific output function or waveform. The output buffer is circular (closed), and is not accessible from the bus.</p>
<p>Request buffer access</p>	<p>Set LOAD REQUEST in the buffer operations register.</p>	<p>The board will assert the LOAD READY flag when the EOF flag in the original function occurs.</p>
<p>Wait for the buffer to open.</p>	<p>Monitor the LOAD READY status flag. The buffer is open when this flag goes HIGH.</p>	<p>The EOF flag in the existing function set causes the LOAD READY bit in the buffer operations register to be asserted.</p> <p>The buffer is now open, and the original functions are being flushed from the buffer.</p>
<p>Load the new function for each active channel into the buffer. Set the end-of-frame (EOF) flag.</p>	<p>Write the function values for all active channels to the output buffer. Set the EOF flag (D16 in the output buffer) HIGH when writing the data value for the last channel in the last group.</p>	<p>New function values for all active channels reside in the buffer. The EOF flag is set HIGH in the buffer location that contains the last channel value in the last channel group.</p> <p>The original functions are still active, and the remaining values are flushed from the buffer as they are sent to the output channels.</p>
<p>(None required)</p>	<p>No further attention is required from the PCI bus.</p>	<p>The buffer returns to circular (closed) mode after the last data value in the original function set leaves the buffer. The new function then commences seamlessly and circulates within the buffer.</p> <p>Both the Load Request control bit and the Load Ready flag are cleared automatically when the buffer closes.</p>

3.15 Analog Output Buffer DMA Operation

DMA transfers to the analog output FIFO buffer are supported in either block-mode or demand-mode, with the board operating as bus master. Bit 02 in the PCI Command register must be set HIGH to select the bus mastering mode. Refer to the PCI-9056 reference manual for a detailed description of the associated DMA configuration registers.

3.15.1 Block Mode

Table 3.15-1 illustrates a *typical* PCI register configuration that would control a non-chaining, non-incrementing **block-mode** DMA transfer in DMA Channel 01, in which a PCI interrupt is generated when the transfer has been completed.

Table 3.15-1. Typical Output DMA Register Configuration; Block Mode

PCI Offset	PCI Register	Function	Typical Value
94h	DMA Mode	Bus width (32); Interrupt on done	0002 0D43h
98h	DMA PCI Address	Initial PCI data source address	*
9Ch	DMA Local Address	Initial (constant) local address	0000 0048h
A0h	DMA Transfer Byte Count	Number of bytes in transfer	*
A4h	DMA Descriptor Counter	Transfer direction (PCI bus to Local bus)	0000 0000h
A9h (A8, D15:8)	DMA Command/Status	Command and Status Register	01h 03h (See Text)

* Determined by specific transfer requirements.

For typical applications, the DMA Command Status Register would be initialized to 0000 0001h, and then changed to 0000 0003h to initiate a transfer.

3.15.2 Demand Mode (Firmware Revision 0006 and higher)

Demand mode transfers are controlled in a manner similar to block mode transfers, with the addition of **demand-mode** operation selected in the DMA mode register (D[12] = HIGH). Demand mode operation also requires the **slow terminate** mode (D[15] = LOW), which is the default state for this control bit. Table 3.15-2 shows a *typical* PCI register configuration for DMA Channel 01 demand mode operation.

Table 3.15-2. Typical Output DMA Register Configuration; Demand Mode

PCI Offset	PCI Register	Function	Typical Value
94h	DMA Mode	Bus width (32)	0002 1943h
98h	DMA PCI Address	Initial PCI data source address	*
9Ch	DMA Local Address	Initial (constant) local address	0000 0048h
A4h	DMA Descriptor Counter	Transfer direction (PCI bus to Local bus)	0000 0000h
A9h (A8, D15:8)	DMA Command/Status	Command and Status Register	01h 03h (See Text)

* Determined by specific transfer requirements.

NOTE: The default analog output DMA channel for demand-mode operation is Channel 01. To operate in DMA Channel-00, set the SWAP DEMAND MODE CHANNELS control bit HIGH in the BCR and use the Channel 00 PCI registers.

3.16 Assembly Configuration Register

The read-only Assembly Configuration register (Table 3.16-1) contains the existing firmware revision and a status field that indicates the availability of optional features.

Table 3.16-1. Assembly Configuration Register

Offset: 0000 0034h

Default: 00XX XXXXh

BIT FIELD	DESCRIPTION
D00-D11	Firmware Revision
D12-D15	(Reserved bit field)
D16	Number of analog input channels: 0 => 16 Analog input channels. 1 => 8 Analog input channels.
D17	Number of analog output channels: 0 => 2 analog output channels. 1 => No analog outputs.
D18-D19	Master clock frequency: 0 => 45.000MHz 1 => (Reserved) 2 => (Reserved) 3 => (Reserved)
D20-D31	(Reserved bit field; returns all-zero).

PMC66-16AISS16AO2

SECTION 4.0

PRINCIPLES OF OPERATION

4.1 General Description

Each of 16 single-ended analog input channels contains a selftest input switching network, a differential amplifier, a scaling network and a 16-Bit ADC (Figure 4.1-1), and provides input ranges of $\pm 10V$, $\pm 5V$ and $\pm 2.5V$. A 256 Ksample FIFO buffer accumulates analog input data for subsequent retrieval through the PCI bus. Two 16-bit analog output channels provide software-selected output ranges of $\pm 2.5V$, $\pm 5V$ or $\pm 10V$, and are accessed either directly through dedicated control registers, or through a 256 Ksample FIFO buffer. A 6-Bit digital port is configured as six independently controlled bidirectional I/O lines.

A PCI interface adapter provides the interface between the controlling PCI bus and an internal local controller, and supports universal signaling. +5 VDC power from the PCI bus is converted into regulated power voltages for the internal analog networks.

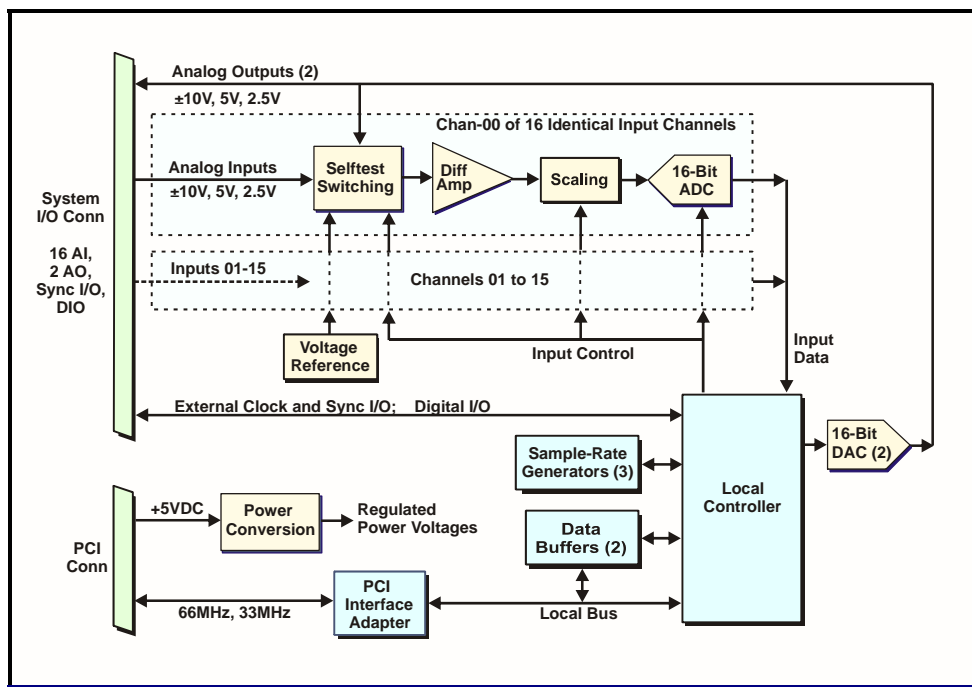

Figure 4.1-1. Functional Block Diagram

Selftest switches at the inputs provide test signals for autocalibration of all input and output channels, and can be configured to accept either differential or single-ended system inputs.

Analog input sampling and output clocking on multiple target boards can be synchronized to a single software-designated initiator board.

4.2 Analog Inputs

Analog-to-digital conversions can be performed on signals from any of several sources, which are selected by the selftest switches shown in Figure 4.1-1. During normal operation, the 16-bit ADC's receive system analog input signals from the system I/O connector. For integrity testing and autocalibration operations, the internal voltage reference and the analog outputs can be routed through the selftest switches to the ADC's. An attenuator in each channel provides the necessary scaling for software-controlled input ranging.

Serial data from each ADC is deserialized and multiplexed into a continuous data stream within the local controller. The output of the multiplexer passes through a digital processor that applies gain and offset correction values obtained during autocalibration. The corrected data is formatted, and the final, processed and formatted data is loaded into the analog input data buffer.

ADC clocking can be supplied either from an internal 24-Bit rate divider operating from the master clock, or from an external source. Triggered bursts can be acquired by using a second internal rate generator or an external input as a trigger source. The burst block-size can be controlled by a 24-Bit counter, or sampling can be configured to operate continuously after a trigger. The ADC external clock and trigger pins can be configured independently as inputs or outputs.

4.3 Input Data Buffer

A 256K-sample FIFO buffer accumulates analog input data for subsequent retrieval through the PCIbus. The buffer is supported by a 'size' register that tracks the number of values in the buffer, and by an adjustable threshold flag that generates a status flag in response to the number of samples contained within the buffer.

4.4 Analog Outputs

Two independent 16-bit DAC's are controlled either directly through dedicated control registers, or through a 256 Ksample FIFO buffer. The buffer can be operated either open for data streaming, or closed (circular) for periodic function generation. Function concatenation from the PCI bus is supported.

Output clocking can be supplied either from a third internal 24-Bit rate generator, or from an external source. Triggered bursts are supported, and share the triggering function with the analog inputs (4.2). The output burst size is controlled by a tag-bit attached to the last output value in a sequence. If the tag-bit is not attached, a burst will operate continuously after a trigger, or until the buffer goes empty.

4.5 Autocalibration

Autocalibration is an embedded firmware utility that calibrates all analog input and output channels to a single internal voltage reference. The utility can be invoked at any time by the control software.

The internal voltage reference is used to calibrate the span of each channel, and a zero-reference is used to calibrate the offset value. Correction values determined during autocalibration are applied to each digitized sample acquired during acquisition, and to each output value written to the DAC channels. Correction values are retained until the autocalibration sequence is repeated, or until power is removed.

4.6 Power Control

Regulated supply voltages of ± 5 VDC and ± 14 VDC are required for the analog networks, and are derived from the +5-Volt input provided by the PCI bus, both by switching preregulators and by linear postregulators.

PMC66-16AISS16AO2

APPENDIX A
LOCAL REGISTER QUICK REFERENCE

APPENDIX A LOCAL REGISTER QUICK REFERENCE

This appendix summarizes the local registers and principal control-bit fields described in Section 3.

Table 3.1-1. Control and Status Registers

OFFSET (Hex)	REGISTER	MODE	DEFAULT	PRIMARY FUNCTION	REF
0000	BOARD CONTROL	RW	2202 00A0h	Board Control Register (BCR).	3.2
0004	DIGITAL I/O PORT	RW	0000 00XXh	Digital I/O port data.	3.9
0008	ANALOG OUTPUT CHAN 00	RW	0000 8000h	Output Channel 00 data.	3.12
000C	ANALOG OUTPUT CHAN 01	RW	0000 8000h	Output Channel 01 data.	3.12
0010	(Reserved)	RO	0000 0000h	---	---
0014	ACTIVE INPUT CHANNELS	RW	0000 FFFh	Active input channels selection mask.	3.4.2
0018	ANALOG INPUT BUFFER	RO	00XX XXXXh	Analog input buffer data.	3.4.5
001C	RATE GENERATOR A	RW	0000 007Eh	Rate-A generator divider; 24 bits.	3.7
0020	RATE GENERATOR B	RW	0000 2760h	Rate-B generator divider; 24 bits.	3.7
0024	AI BURST BLOCK SIZE	RW	0000 0400h	Analog input burst size.	3.4.4.2
0028	INPUT BUFFER SIZE	RO	0000 0000h	Number of data values in the input buffer.	3.4.5.2
002C	INPUT BUFFER THRESHOLD	RW	0003 FFEh	Input buffer status flag threshold.	3.4.5.2
0030	PRIMARY STATUS	RW	0000 0X00h	Principal status-flag register	3.11
0034	ASSEMBLY CONFIGURATION	RO	000X XXXXh	Options and firmware revision.	3.16
0038	Autocal Values *	RW	0000 XXXXh	Autocal value readback.	---
003C	BUFFERED OUTPUT OPERATIONS	RW	0000 1043h	Buffered Analog Outputs Control	3.13.2.3
0040	OUTPUT BUFFER THRESHOLD	RW	0003 FFEh	Output buffer status flag threshold.	3.13.2.3
0044	OUTPUT BUFFER SIZE	RO	0000 0000h	Number of data values in the output buffer.	3.13.2.3
0048	ANALOG OUTPUT BUFFER	WO	0000 0000h	Analog Output Data Buffer.	3.13.2
004C	RATE GENERATOR C	RW	0000 007Eh	Rate-C generator divider; 24 bits.	3.13.4.1.2
0050-007C	(Reserved)	---	---	---	---

* Maintenance register; Shown for reference only.

Table 3.2-1. Board Control Register (BCR)

Offset: 0000h

Default: 2202 00A0h

BIT	MODE ¹	DESIGNATION	DEF	DESCRIPTION	REF
D00-D02	RW	ANALOG INPUT MODE (AIM)	0	Analog input mode: 0 => Differential system inputs 1 => Single-ended system inputs 2 => Zero selftest 3 => VREF selftest 4 => Output Channel 00 5 => Output Channel 01 6,7 => (Reserved)	3.4.1
D03	RW	INPUT BUFFER UNDERFLOW	0	Set HIGH if the input buffer underflows. Stays HIGH until cleared from the bus or by a board reset.	3.4.5.1
D04-D05	RW	INPUT RANGE A	2	Analog input Range-A; Channels 0,1,4,5,8,9,12,13: 0 => ±2.5V 2 => ±10V 1 => ±5V 3 => (Reserved)	3.4.3
D06-D07	RW	INPUT RANGE B	2	Analog input Range-B; Channels 2,3,6,7,10,11,14,15 0 => ±2.5V 2 => ±10V 1 => ±5V 3 => (Reserved)	3.4.3
D08	RW	INPUT S/W CLOCK ²	0	Initiates a single sample of active input channels. Overrides existing input clocking source.	3.4.4
D09	RW	ENABLE INPUT BURST	0	Enables triggered burst input acquisition.	3.4.4.2
D10	RO	INPUT BURST BUSY	0	HIGH when a triggered input burst is in progress.	3.4.4.2
D11	RW	INPUT S/W TRIGGER ²	0	Initiates a single input data burst. Overrides existing burst triggering source.	3.4.4.2
D12	RW	ENABLE INPUT BUFFER	0	Enables the analog input buffer for accepting data.	3.4.5.1
D13	RW	CLEAR INPUT BUFFER ²	0	Clears (empties) the analog input data buffer.	3.4.5.1
D14	RO	INPUT BUFFER THRESHOLD FLAG ³	0	HIGH when the number of values in the input buffer exceeds the selected buffer threshold.	3.4.5.2
D15	RW	INPUT BUFFER OVERFLOW	0	Set HIGH if the input buffer overflows. Stays HIGH until cleared from the bus or by a board reset.	3.4.5.2
D16-D17	RW	OUTPUT RANGE	2	Analog Output Voltage Range: 0 => ±2.5V 2 => ±10V 1 => ±5V 3 => (Reserved)	3.12.1 3.13.1.3
D18	RW	SIMULTANEOUS OUTPUTS	0	When HIGH, all outputs update simultaneously in response to an output clock. When LOW, each output is updated immediately when new data is received.	3.12.2.2 3.13.4.2
D19	RW	ENABLE BUFFERED OUTPUTS	0	When HIGH, enables the analog output FIFO buffer, and disables the analog output registers ANALOG OUTPUT CHAN xx.	3.12 3.13
D20	RW	OUTPUT S/W CLOCK ^{2,3}	0	Produces a single analog output clock. Overrides existing output clocking source.	3.12.2.2 3.13.4.1
D21	RW	TRIGGER INITIATOR	0	Configures the shared analog input/output hardware trigger pin as an output if HIGH, or as an input if LOW.	3.4.4.2
D22	R/W	ENABLE RATE-C GENERATOR	0	Enables the Rate-C generator for analog outputs.	3.13.4.1.2
D23	R/W	OUTPUT SW TRIGGER ³	0	Output Burst S/W Trigger.	3.13.5.2
D24	RW	ANALOG INPUT CLK INITIATOR	0	Configures the analog input I/O clock as an <i>output</i> if HIGH, or as an <i>input</i> if LOW.	3.4.4
D25	RW	OFFSET BINARY	1	Selects offset-binary analog I/O data format when HIGH, or two's complement when LOW.	3.6
D26	RW	ENABLE RATE-A GENERATOR	0	Enables the Rate-A generator for analog inputs.	3.7
D27	RW	ENABLE RATE-B GENERATOR	0	Enables the Rate-B generator for triggered bursts.	3.7
D28	RW	AUTOCAL ²	0	Initiates an autocalibration operation when asserted. Clears automatically upon completion.	3.10
D29	RO	AUTOCAL PASS	1	Set HIGH at reset or autocal initialization. A HIGH state after autocal confirms a successful calibration.	3.10
D30	R/W	ANALOG INPUT WARP MODE	0	Selects analog input warp mode.	3.7
D31	RW	INITIALIZE ²	0	Initializes the board. Sets all register defaults.	3.3.2

Table 3.3-1. Configuration Operations

Operation	Maximum Duration
PCI configuration registers are loaded from internal ROM	3 ms
Internal control logic is configured from internal ROM	300 ms
Internal control logic is initialized	3 ms

Table 3.4-1. Active Input Channels Register

Offset: 0014h

Default: 0000 FFFFh

BIT	MODE	CHANNEL-ENABLE	DEF	DESCRIPTION
D00	RW	INPUT 00	1	Analog input channel selection mask.
D01	RW	INPUT 01	1	
D02	RW	INPUT 02	1	
D03	RW	INPUT 03	1	
D04	RW	INPUT 04	1	
D05	RW	INPUT 05	1	
D06	RW	INPUT 06	1	
D07	RW	INPUT 07	1	
D08	RW	INPUT 08	1	
D09	RW	INPUT 09	1	
D10	RW	INPUT 10	1	
D11	RW	INPUT 11	1	
D12	RW	INPUT 12	1	
D13	RW	INPUT 13	1	
D14	RW	INPUT 14	1	
D15	RW	INPUT 15	1	
D16-D31	RO	(Reserved)	0000h	

Table 3.4-2. Input Data Buffer

Offset: 0018h

Default: 00XX XXXXh

DATA BIT	DESIGNATION	DESCRIPTION
D00	DATA00	Data value least significant bit (LSB)
D01-D14	DATA01 - DATA14	Data value intermediate bits
D15	DATA15	Data value most significant bit (MSB)
D16	FIRST-CHANNEL TAG	Tag assigned to first (lowest-numbered) active channel.
D17	END OF BURST (EOB)	Identifies the last input value in a burst.
D18-D31	(Reserved)	Always zero.

Table 3.4-3. Input Buffer Threshold Register

Offset: 002Ch

Default: 0003 FFFEh

BIT	MODE	DESIGNATION	DEF	DESCRIPTION
D00-D18	RW	INPUT BUFFER THRESHOLD	3 FFFEh	Specifies the number of values in the input buffer, above which the threshold flag is asserted HIGH.
D19	RO	INPUT BUFFER THRESHOLD FLAG ¹	0	HIGH when the number of values in the input buffer exceeds the specified buffer threshold.
D20-D31	RO	Reserved	0	---

1. Duplicated in the BCR.

Table 3.5-1. Typical Input DMA Register Configuration; Block Mode

PCI Offset	PCI Register	Function	Typical Value
80h	DMA Mode	Bus width (32); Interrupt on done	0002 0D43h
84h	DMA PCI Address	Initial PCI data source address	*
88h	DMA Local Address	Initial (constant) local address	0000 0018h
8Ch	DMA Transfer Byte Count	Number of bytes in transfer	*
90h	DMA Descriptor Counter	Transfer direction (Local bus to PCI bus)	0000 0008h
A8h (D7:0)	DMA Command/Status	Command and Status Register	01h, 03h (See Text)

* Determined by specific transfer requirements.

Table 3.5-2. Typical Input DMA Register Configuration; Demand Mode

PCI Offset	PCI Register	Function	Typical Value
80h	DMA Mode	Bus width (32)	0002 1943h
84h	DMA PCI Address	Initial PCI data source address	*
88h	DMA Local Address	Initial (constant) local address	0000 0018h
90h	DMA Descriptor Counter	Transfer direction (Local bus to PCI bus)	0000 0008h
A8h (D7:0)	DMA Command/Status	Command and Status Register	01h, 03h (See Text)

* Determined by specific transfer requirements.

Table 3.7-1. Analog Input and Trigger Rate Generator Registers (Rate-A,B)

Offset: 001Ch (Rate-A), 0020h (Rate-B)

Default: 0000 007E (Rate-A), 0000 2760h (Rate-B)

DATA BIT	MODE*	DESIGNATION	DEFAULT	DESCRIPTION
D00-D23	R/W	Ndiv	---	Rate generator frequency control
D24-D31	RO	(Inactive)	0	---

* R/W = Read/Write, RO = Read-Only.

Table 3.7-2. Input Rate Generator Frequency Selection

Ndiv		FREQUENCY Fgen (45.000 MHz Master Clock)*
(Dec)	(Hex)	(kHz)
45	002D	1000
46	002E	978
---	---	Fgen (Hz) = Fclk (Hz) / Ndiv **

* ±0.003 percent.

** Fclk = master clock frequency; e.g.: 45.000MHz.

Table 3.9-1. Digital I/O Port Register

Offset: 0004h

Default: 0000 00XXh

DATA BIT	MODE*	DESIGNATION	DEFAULT	DESCRIPTION
D00	RW	DIO 00 DATA	X	Digital I/O Data; Bits 00-05
D01	RW	DIO 01 DATA	X	
D02	RW	DIO 02 DATA	X	
D03	RW	DIO 03 DATA	X	
D04	RW	DIO 04 DATA	X	
D05	RW	DIO 05 DATA	X	
D06-D07	RW	(Reserved)	0h	
D08	RW	DIO 00 OUTPUT SELECT	0	DIO direction control; High for output.
D09	RW	DIO 01 OUTPUT SELECT	0	
D10	RW	DIO 02 OUTPUT SELECT	0	
D11	RW	DIO 03 OUTPUT SELECT	0	
D12	RW	DIO 04 OUTPUT SELECT	0	
D13	RW	DIO 05 OUTPUT SELECT	0	
D14-D31	RO	(Reserved)	0h	Read back as all-zero.

Table 3.11-1 Primary Status Register

Offset 0x0030

Default 0x0000 0X00

SELECTION BIT ¹	CRITICAL EVENT	RESPONSE BIT ²	REFERENCE PARAGRAPH
D00	Autocal completed	D16	3.10
D01	Input Buffer threshold flag HIGH-to-LOW transition	D17	3.4.5.2
D02	Input Buffer threshold flag LOW-to-HIGH transition	D18	
D03	Input Buffer Overflow or Underflow	D19	3.4.5.1
D04	Analog Input Burst initiated (BURST BUSY LO-HI)	D20	3.4.4.2
D05	Analog Input Burst Completed (BURST BUSY HI-LO)	D21	
D06	Analog Input Clock	D22	3.4.4
D07	Analog Output Clock	D23	3.13.4
D08	Digital I/O Port DIO 00 LOW-to-HIGH transition	D24	3.9
D09	Output Buffer threshold flag HIGH-to-LOW transition	D25	3.13.2.3
D10	Output Buffer threshold flag LOW-to-HIGH transition	D26	
D11	Output Load-Ready Flag HIGH-to-LOW transition	D27	3.13.3.3
D12	Output Load-Ready Flag LOW-to-HIGH transition	D28	
D13	Analog Output Burst Ready	D29	3.13.5.2
D14	Output Buffer Overflow or Frame Overflow	D30	3.13.2.3 3.13.3.3
D15	(Reserved)	D31	---

1. Event selection. Enables assertion of the corresponding response bit when the selected event occurs.
2. Event response. Asserted HIGH when a selected event occurs. Remains HIGH until cleared LOW.

Table 3.12-1. Analog Output Channel Data Register

Offset: 0008h - 0014h

Default: 0000 8000h

DATA BIT	DESIGNATION	DESCRIPTION
D00	DATA00	Data value least significant data bit
D01-D14	DATA01 - DATA14	Data value intermediate data bits
D15	DATA15	Data value most significant data bit
D16-D31	(Reserved)	Data in this field is ignored.

Table 3.12-2 Simultaneous Output Clock Source Selection

Register	Control Bit	S/W Clock (BCR)	Rate-C Gen	External Input
BCR	SIMULTANEOUS OUTPUTS	HIGH	HIGH	HIGH
	ENABLE RATE-C GENERATOR	X	HIGH	X
BOR *	ANALOG OUTPUT CLK INITIATOR	X	HIGH	LOW

* Buffered Outputs Operations register (Table 3.13-2).

Table 3.13-1. Summary of Buffered Output Control Parameters

Parameter	Mode	Description
Data Control	Active Channels; Channel Group	A single set of all active output channels constitutes an Active Channel Group . Active channels are selected under a channel mask.
	Data Frame	All data values in the buffer comprise a <i>Data Frame</i> .
	Data Coding	Output data can be coded either in offset-binary format or in two's complement format.
Buffer Configuration	Open	Data read from the buffer is used and then discarded, until the buffer is empty.
	Circular (closed)	Data within the buffer is recirculated. Each value read from the output of the buffer FIFO is written back to the input of the FIFO. An end-of-frame (EOF) flag tracks the movement of data through the buffer.
Clock Source	External	External hardware provides the sample clock.
	Internal	The sample clock is provided by an internal rate generator, at a rate determined by the sample rate control register.
Clocking Mode	Simultaneous	At each clock occurrence, the next channel group (i.e.: a single group of all active channel values) in the output buffer is transferred to the respective analog output channels. All outputs are updated simultaneously.
	Sequential	At each clock occurrence, the next active channel value in the output buffer is transferred to the associated analog output channel, which is updated immediately.
Sampling Mode	Continuous	The contents of the output buffer are sampled continuously at the selected clock rate.
	Triggered Burst	A single data frame in the buffer is clocked to the outputs.

Table 3.13-2. Buffered Output Operations Register

Offset: 003Ch

Default: 0000_1043h

BIT	MODE	DESIGNATION	DEF	DESCRIPTION	REF
D00	R/W	AO CHAN 00 ACTIVE	1	Active-channel mask for analog output channels. HIGH => Active; LOW => Inactive.	3.4.1.1
D01	R/W	AO CHAN 01 ACTIVE	1		
D02-D03	R/W	(Reserved)	0h		
D04	R/W	ANALOG OUTPUT CLK INITIATOR	0	Selects the internal Rate-C generator for output clocking if HIGH, or the Output Clock I/O hardware input if LOW.	3.13.4.1
D05	R/W	ENABLE OUTPUT CLOCKING	0	Enables output clocking when HIGH. Disables clocking when LOW. Default is LOW (clocking disabled).	3.13.4
D06	RO	OUTPUT CLOCK READY	1	Indicates when HIGH that an output clock will be accepted. If LOW, indicates that the output will not respond to a clock.	3.13.4
D07	R/W	OUTPUT SW CLOCK *	0	Produces a single output clock event when asserted. Independent of clocking mode. Duplicated in the BCR.	3.13.4.1
D08	R/W	CIRCULAR BUFFER	0	Selects circular buffer configuration if HIGH, or open self-flushing buffer configuration if LOW. Access for loading new data into the circular buffer must be requested by asserting LOAD REQUEST. Default is LOW; i.e. open buffer.	3.13.2.5
D09	R/W	LOAD REQUEST *	0	When set HIGH, requests loading access to the circular buffer. Initializes LOW.	3.13.3.3
D10	RO	LOAD READY	0	Set HIGH when the frame index passes through zero, if both CIRCULAR BUFFER and LOAD REQUEST are HIGH. When HIGH, indicates that the circular buffer is ready to accept new data. Available also in the PSR. Defaults HIGH.	3.13.3.3
D11	R/W	CLEAR OUTPUT BUFFER *	0	Resets the output buffer to empty.	3.13.2.3
D12	RO	AO BUFFER EMPTY	1	Indicates the analog output buffer is empty.	3.13.2.3
D13	RO	AO BUFFER THRESHOLD	0	Analog output buffer threshold flag. Duplicated in the AO Buffer Threshold register.	3.13.2.3
D14	RO	(Reserved)	0	Inactive; Returns zero.	---
D15	RO	AO BUFFER FULL	0	Indicates the output buffer is full.	3.13.2.3
D16	R/W	AO BUFFER OVERFLOW	0	Set HIGH when data is written to a full buffer. **	3.13.2.3
D17	R/W	FRAME OVERFLOW	0	Set HIGH when data is written to a closed buffer. **	3.13.2.3
D18	RO	BURST READY	0	If HIGH, indicates that a burst trigger will be accepted. If LOW, indicates that the output will not respond to a trigger.	3.13.5
D19	R/W	ENABLE OUTPUT BURST	0	Enables analog output burst operation.	3.13.5.2
D20	R/W	OUTPUT SW TRIGGER *	0	Produces a single output trigger event when asserted. Clears LOW automatically when the clock event is completed. Independent of triggering mode. Duplicated in the BCR.	3.13.5.2
D21	R/W	SWAP DEMAND MODE CHANNELS	0	Reverses the default demand-mode DMA channels for analog inputs and outputs	3.5 3.15
D22-D31	RO	(Reserved)	0	Inactive. Returns all-zero.	---

* Clears LOW automatically when operation is completed.

** Remains HIGH until cleared by a direct write as LOW, or by initialization.

Table 3.13-3. Analog Output Buffer

Offset: 0048h

Default: N/A (Write-Only)

BIT	MODE*	DESIGNATION	DESCRIPTION
D00	WO	DATA 00	Least significant data bit
D01-D14	WO	DATA 01 - DATA 14	Intermediate data bits
D15	WO	DATA 15	Most significant data bit
D16	WO	EOF FLAG	End-of-frame (EOF) flag.
D17-D31	WO	---	(Inactive)

* WO indicates write-only access. Read-access returns all-zero value.

Table 3.13-4. Output Buffer Size Register

Offset: 0044h

Default: 0000 0000h

DATA BIT	MODE*	DESIGNATION	DEF	DESCRIPTION
D00-D18	RO	BUFFER SIZE	0 0000h	Number of values in the output buffer
D19-D31	RO	(Inactive)	0	---

Table 3.13-5. Output Buffer Threshold Register

Offset: 0040h

Default: 0003 FFFEh

BIT	MODE	DESIGNATION	DEF	DESCRIPTION
D00-D18	RW	OUTPUT BUFFER THRESHOLD	3 FFFEh	Specifies the number of values in the output buffer, above which the threshold flag is asserted HIGH.
D19	RO	OUTPUT BUFFER THRESHOLD FLAG	0	HIGH when the number of values in the output buffer <i>exceeds</i> the specified buffer threshold.
D20-D31	RO	Reserved	0	---

Table 3.13-6. Output Sample Rate Control Register (Rate-C)

Offset: 004Ch

Default: 0000_007Eh

DATA BIT	MODE	DESIGNATION	DESCRIPTION
D00	R/W	RATE 00	Least significant rate bit
D01-D22	R/W	RATE 01 - RATE 22	Intermediate rate bits
D23	R/W	RATE 23	Most significant rate bit
D24-D31	RO	---	Inactive. Returns all-zero.

Table 3.13-7. Output Sample Rate Selection

Ndiv		FREQUENCY Fgen (45.000 MHz Master Clock)*
(Dec)	(Hex)	(kHz)
45	002D	1000
46	002E	978
---	---	Fclock (Hz) = Fclk (Hz) / Ndiv **

* ±0.003 percent.

** Fclock = master clock frequency; e.g.: 45.000MHz.

Table 3.15-1. Typical Output DMA Register Configuration; Block Mode

PCI Offset	PCI Register	Function	Typical Value
94h	DMA Mode	Bus width (32); Interrupt on done	0002 0D43h
98h	DMA PCI Address	Initial PCI data source address	*
9Ch	DMA Local Address	Initial (constant) local address	0000 0048h
A0h	DMA Transfer Byte Count	Number of bytes in transfer	*
A4h	DMA Descriptor Counter	Transfer direction (PCI bus to Local bus)	0000 0000h
A9h (A8, D15:8)	DMA Command/Status	Command and Status Register	01h 03h (See Text)

* Determined by specific transfer requirements.

Table 3.15-2. Typical Output DMA Register Configuration; Demand Mode

PCI Offset	PCI Register	Function	Typical Value
94h	DMA Mode	Bus width (32)	0002 1943h
98h	DMA PCI Address	Initial PCI data source address	*
9Ch	DMA Local Address	Initial (constant) local address	0000 0048h
A4h	DMA Descriptor Counter	Transfer direction (PCI bus to Local bus)	0000 0000h
A9h (A8, D15:8)	DMA Command/Status	Command and Status Register	01h 03h (See Text)

* Determined by specific transfer requirements.

Table 3.16-1. Assembly Configuration Register**Offset: 0000 0034h****Default: 00XX XXXXh**

BIT FIELD	DESCRIPTION
D00-D11	Firmware Revision
D12-D15	(Reserved bit field)
D16	Number of analog input channels: 0 => 16 Analog input channels. 1 => 8 Analog input channels.
D17	Number of analog output channels: 0 => 2 analog output channels. 1 => No analog outputs.
D18-D19	Master clock frequency: 0 => 45.000MHz 1 => (Reserved) 2 => (Reserved) 3 => (Reserved)
D20-D31	(Reserved bit field; returns all-zero).

APPENDIX B

COMPARISON of PMC66-16AISS16AO2 and PMC66-16AISS8AO4

Appendix B

Comparison of PMC66-16AISS16AO2 and PMC66-16AISS8AO4

Operation of the PMC66-16AISS16AO2 is similar to that of the PMC66-16AISS8AO4. This appendix summarizes the principal similarities and differences between the two products, and is provided as a general guide rather than a definitive list of requirements.

B.1. Comparison of Features

Table B.1 compares principal PMC66-16AISS16AO2 and PMC66-16AISS8AO4 features. Those features that have not changed are shaded; Modified features are in bold type.

Table B.1. PMC66-16AISS8AO4, PMC66-16AISS16AO2 Comparison

Feature	PMC66-16AISS8AO4	PMC66-16AISS16AO2
Input Channels	Eight 16-Bit ADC's; SAR	Sixteen 16-Bit ADC's; SAR
Input Sample Rates	Zero to 2.0MSPS/Chan	Zero to 1.0MSPS/Chan
Input Buffer	256K-Sample FIFO	256K-Sample FIFO
Input Ranges	±10V, ±5V, ±2.5V	±10V, ±5V, ±2.5V
Output Channels	Four 16-Bit Dac's	Two 16-Bit Dac's
Output Registers *	Four; One per channel	Two; One per channel
Output Burst S/W Trigger	BOR only	Duplicated in BOR and BCR
Output Buffer *	256K-Sample FIFO	256K-Sample FIFO
Output FIFO Buffer Organization	Fixed size, with adjustable threshold flag	Fixed size, with adjustable threshold flag
Output Clock Rates	Zero to 1.0MSPS/Chan	Zero to 1.0MSPS/Chan
Output Configuration	Single-Ended	Single-Ended
Function Generation	Yes	Yes
Digital I/O Port	16-Bit Bidirectional TTL; Byte oriented.	6-Bit Bidirectional TTL; Bit oriented.
PCI Adapter	PCI-9056 (66MHz PCI)	PCI-9056 (66MHz PCI)
Rate Generators	Three, with 24-Bit dividers	Three, with 24-Bit dividers
Interrupt	None. (Replaced with a primary status register)	None. (Replaced with a primary status register)
PCI Interface	PCI 2.3; 33MHz/66MHz	PCI 2.3; 33MHz/66MHz
DMA (Buffers)	Block mode, Demand mode	Block mode, Demand mode
Local Clock	40-45 MHz	44-47 MHz

* Output control is selectable as 'buffer' or 'register.'

B.2. Migration from PMC66-16AISS8AO4

Table 3.1-1. Control and Data Registers:

- Control registers "Analog Output Channel 02" and "Analog Output Channel 03" have been deleted:
- The "Input Configuration" control register has been replaced with two new registers:
Active Input Channels register,
AI Burst Block Size register.

Table 3.2-1. Board Control Register:

- Output channels 02, 03 have been removed from the AIM[] control field.
- The output S/W burst trigger control bit (Table 3.13-2) is duplicated in the BCR.
- Reserved control bit D30 now selects the ADC warp mode (Paragraph 3.7).

Paragraph 3.4-2. Active Channels Selection:

Table 3.4-1. Active Input Channels Register:

- The Active Input Channel mask has been relocated to a new "Active Input Channels" register.
- The size of the channel mask has increased from eight bits to sixteen.

Paragraph 3.4.4.2. Burst Sampling:

- The "Input Configuration" register has been replaced with the "AI Burst Block Size" control register

Paragraph 3.7 Rate-A/B Generators:

- BCR reserved control bit D30 now selects the ADC warp mode.

Paragraph 3.9. Digital I/O Port:

Table 3.9-1. Digital I/O Port Register:

- The digital I/O port now consists of six individually controlled I/O lines.

Paragraph 3.10 Autocalibration:

- Autocalibration duration has increased to accommodate 16 input channels.

Table 3.13-2. Buffered Output Operations Register

- The analog output active-channel selection field has been reduced from four bits to two..

Paragraph 3.13.5.2. Data Bursts (Analog outputs):

- Output data bursts can now be triggered from the Buffered Outputs Operations register or from the BCR.

Paragraphs 3.5, 3.15. DMA Operation:

- Demand-mode DMA is now available..

Table 3.16-1. Assembly Configuration Register:

- Option fields are updated to reflect PMC66-16AISS16AO2 ordering options.

Revision History:

08-25-2007: Revised for demand mode DMA operation.

Copyright (C) 2007 General Standards Corp.

Additional copies of this manual or other General Standards Co. literature may be obtained from:

General Standards Corp.
8302A Whitesburg Dr.
Huntsville, Alabama 35802
Telephone: (256) 880-8787
FAX: (256) 880-8788

The information in this document is subject to change without notice.

General Standards Corp. makes no warranty of any kind with regard to this material, including, but not limited to, the implied warranties of merchantability and fitness for a particular purpose. Although extensive editing and reviews are performed before release to ECO control, General Standards Corp. assumes no responsibility for any errors that may exist in this document. No commitment is made to update or keep current the information contained in this document.

General Standards Corp. does not assume any liability arising out of the application or use of any product or circuit described herein, nor is any license conveyed under any patent rights or any rights of others.

General Standards Corp. assumes no responsibility resulting from omissions or errors in this manual, or from the use of information contained herein.

General Standards Corp. reserves the right to make any changes, without notice, to this product to improve reliability, performance, function, or design.

All rights reserved.

No part of this document may be copied or reproduced in any form or by any means without prior written consent of General Standards Corp.

General Standards Corporation
High Performance Bus Interface Solutions