

## Cabinets: battery charger RS SERIES

Models	Available Configurations	Dimensions Height x Width x Depth	Weight (approximate)
RS2100	X, BX	710 x 533 x 459 (mm) 28.0 x 21.0 x 18.0 (in.)	90 Kg 198 lbs
RS2400	X, BX	1613 x 600 x 600 (mm) 63.5 x 23.6 x 23.6 (in.)	190 Kg 418 lbs
RS3600 (note 1)	BI, BIP	1613 x 915 x 762 (mm) 63.5 x 36.0 x 30.0 (in.)	225 Kg 495 lbs
RS4300 (note 1)	BI, BIP	1700 x 1100 x 916 (mm) 66.9 x 43.3 x 36.0 (in.)	350 Kg 770 lbs

**Note 1:** the battery could be installed in the same cabinet as the battery charger (BI and BIP configurations) only if the battery is of small dimensions.

### CARACTERISTICS:

**Material:** cold laminated steel

**Type:** NEMA 1 (other types are optional)

**Ventilation:** steel ventilation grilles (louvres are optional)

**Color and finish:** gray ASA 61 semi-gloss (other colors and finishes are optional)

**Service access:** only front access for servicing is required

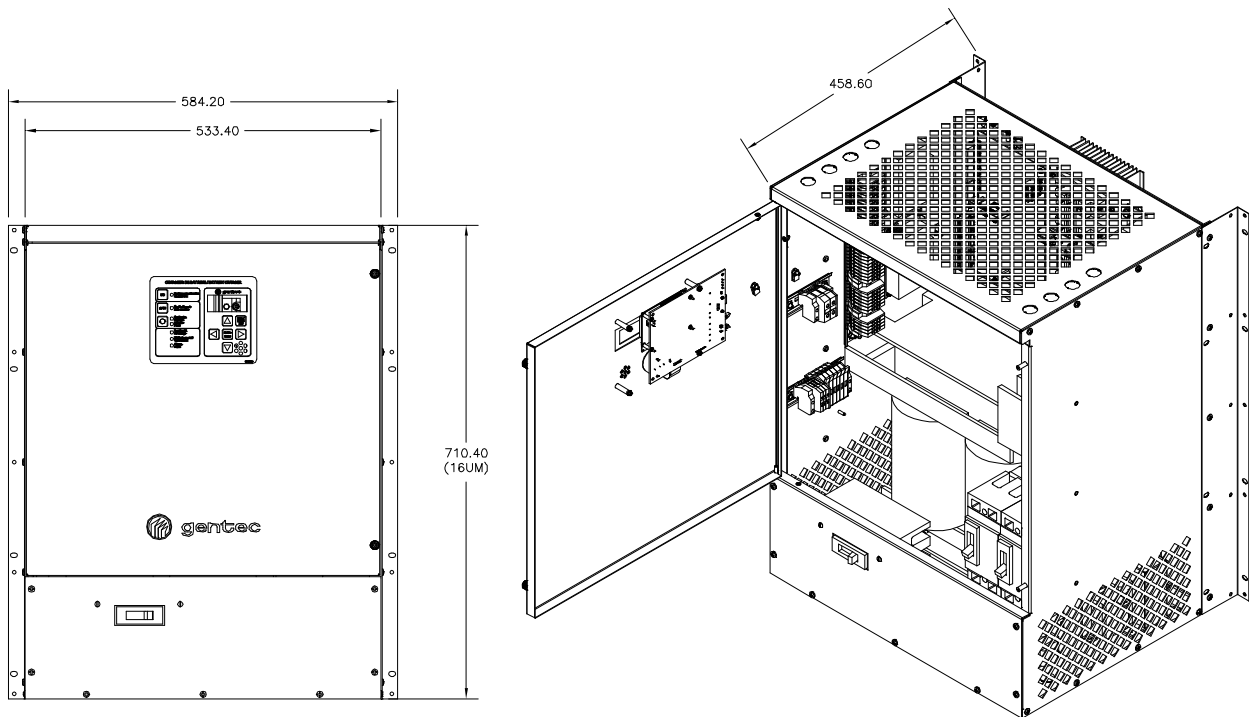

Cabinet RS2100 (see note 2)

**Note 2:** the drawings of the cabinets presented in this brochure can be provided with options. Therefore, they do not represent necessarily basic battery chargers.

Cabinet RS2400 (see note 2, page 1)

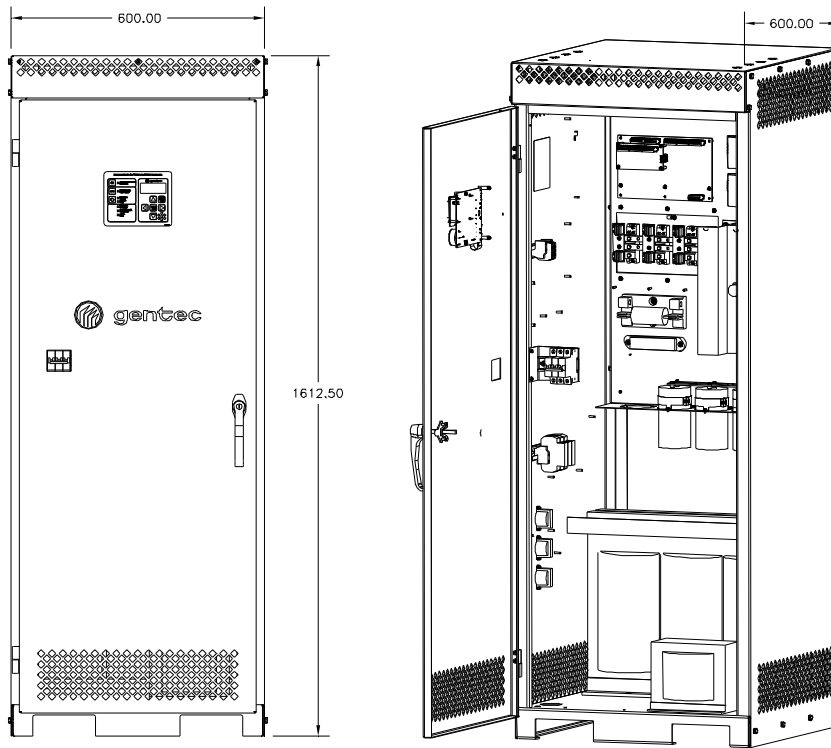

Cabinet RS4300 (see note 2, page 1)

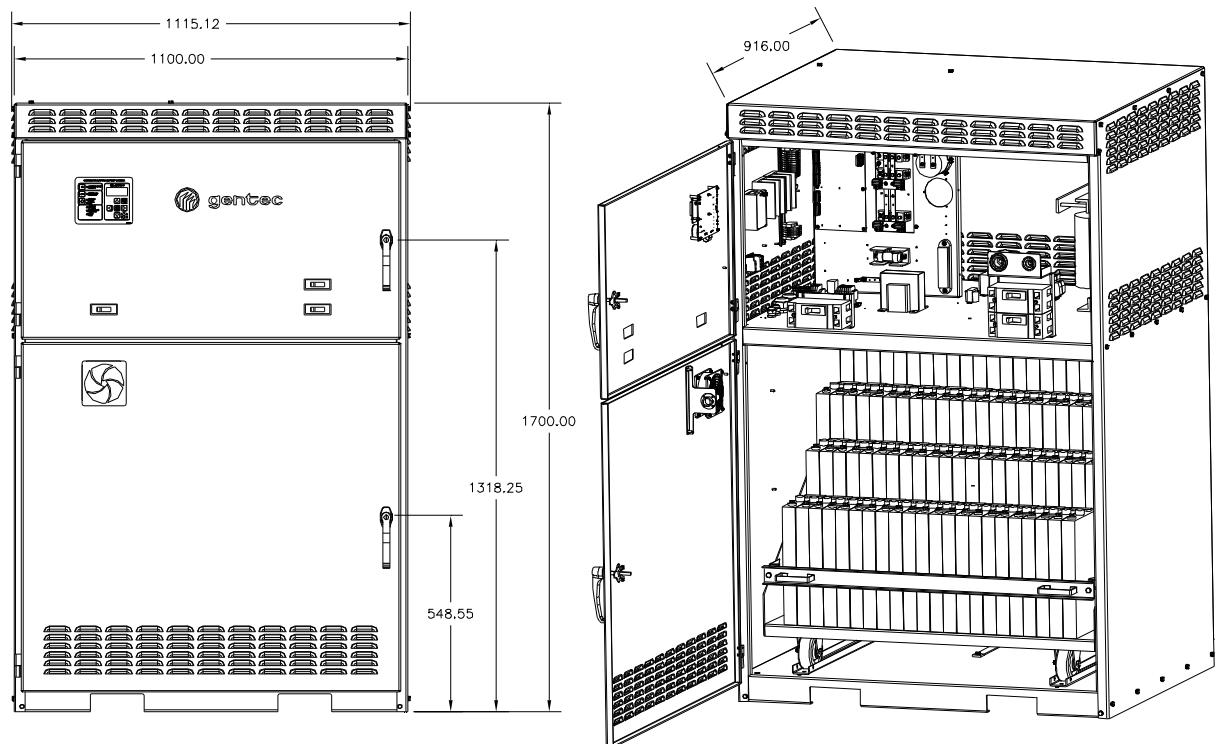

**Note 3:** basically, the multi-step battery rack is fixed, the mobile rack is optional. The louvres are also optional.

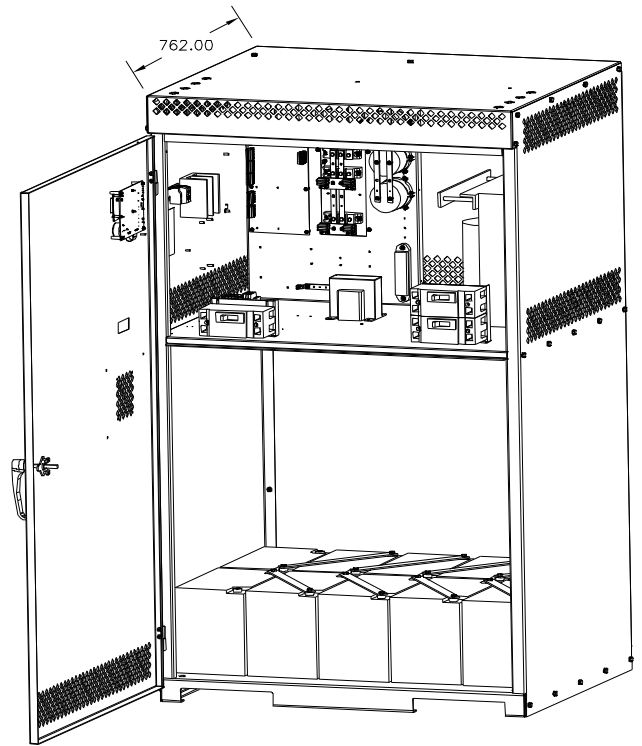
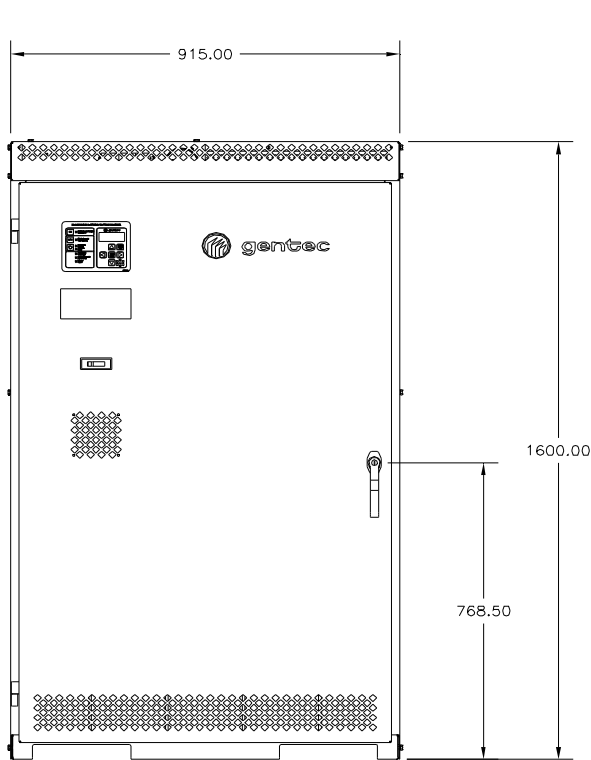

**Cabinet RS3600-1 (see note 2, page 1)  
(BI configuration, single-row batteries)**

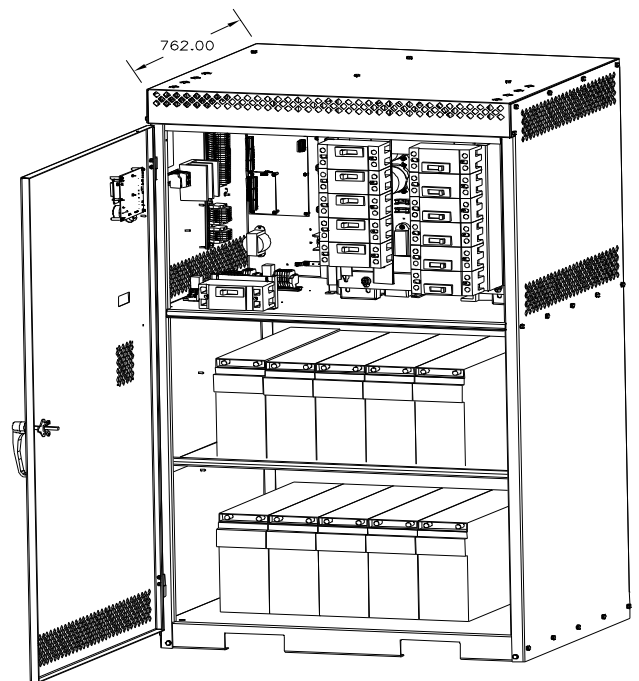
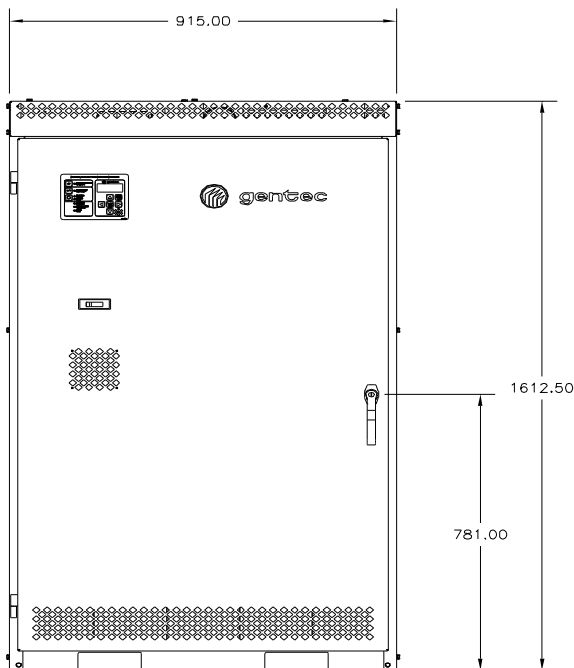

**Cabinet RS3600-2 (see note 2, page 1)  
(BIP configuration, double-row batteries)**