

FEATURES

- > Compact design saves precious space while isolating 25kV
- > Rugged HV wire leads make installation easy
- > Mounting options in any axis



PRODUCT SPECIFICATIONS

Contact & Relay Ratings	Units	G62A
Contact Form		A
Contact Arrangement		SPST-NO
Contact Material (moveable/stationary)		molybdenum /tungsten
Dielectric		Inert Gas
Voltage, Test Max., Contacts & to Base (15 µA Leakage Max.) dc or 60Hz	kV Peak	30
Voltage, Operating Max., Contacts & to Base (15 µA Leakage Max.) dc or 60 Hz	kV Peak	25
Current, Load Switching		Contact factory*
Current, Continuous Carry Max dc or 60 Hz	Amps	18
Coil Hi-Pot (V RMS, 60 Hz)	V	500
Resistance, Contact Max @ 1A, 28 Vdc	ohms	0.5
Operate Time	ms	15
Release Time	ms	15
Life, Mechanical	cycles	1 million
Weight, Nominal	g (oz)	336 (12)
Vibration, Operating, Sine (55-500 Hz Peak)	G's	10
Shock, Operating, 1/2 Sine 11ms (Peak)	G's	20
Temperature Ambient Operating	°C	-55 to +85

*Consult factory for load switching applications.

COIL RATINGS

Nominal, Volts dc	12	26.5	115
Pick-up, Volts dc, Max.	9	18	90
Drop-Out, Volts dc	.5 - 5	1 - 10	5 - 55
Coil Resistance (Ohms ±10%)	30	125	2000

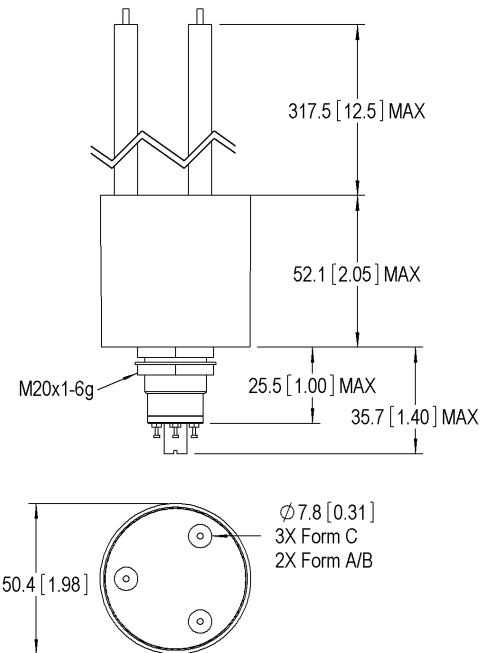

PART NUMBER SYSTEM

G62A	7	4	1
Coil Voltage	7 = 12 Vdc, Turret Terminal 8 = 26.5 Vdc, Turret Terminal 9 = 115 Vdc, Turret Terminal		
High Voltage Connections		4 = Flying Leads, 12" 7 = Flying Leads, 72" 8 = Flying Leads, 36"	
Mounting			1 = Threaded

Ratings listed are for 25°C, sea level conditions